

# **ACTP715**

## **Vehicular Gate Operator**

Installation Instruction & Owner's Manual



# **PLATINUM ACCESS SYSTEMS™**





# Installation Instructions & Safety Information Manual

## ACTP715 Vehicular Gate Operator Class I, Class II, Class III, and Class IV

### TABLE OF CONTENTS

Gate Operator Class Categories & Example .....	2
Protection Against Entrapment .....	3
Use & Application .....	4
Important Safety Instructions .....	5
Maintenance Instructions .....	6
Intended Use .....	7
Types of Installations .....	8-9
Mounting Instructions .....	10-12
Entrapment Protection .....	13
Inductive Loops .....	14-15
Alarm Reset Switch .....	16
Warning Placards .....	
Electrical .....	17-19
Primary Unit .....	20
Primary/Secondary Connections .....	21
Loop Rack .....	22
Accessory Connections .....	23-26
Selectable Features .....	27-28
Solar Installation .....	29
Parts Diagram .....	30

## Gate operator class categories and examples

### READ AND FOLLOW ALL INSTRUCTIONS MANUAL BEFORE ATTEMPTING ANY INSTALLATION

#### Residential Vehicular Gate Operator Class I

A vehicular gate operator (or system) intended for use in a home of one-to four single family dwelling, or a garage or parking area associated therewith.

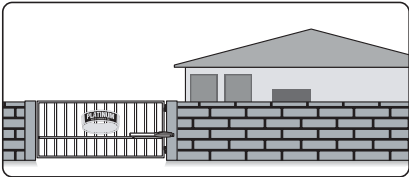

#### Commercial/General Access Vehicular Gate Operator Class II

A vehicular gate operator (or system) intended for use in a commercial location or building such as a multi-family housing unit (five or more single family units), hotel, garages, retail store, or other building servicing the general public.

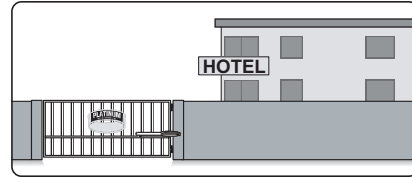

#### Industrial/Limited Access Vehicular Gate Operator Class III

A vehicular gate operator (or system) intended for use in an industrial location or building such as a factory or loading dock area or other locations not intended to service the general public.

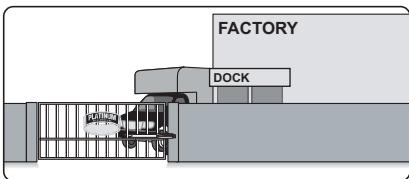

#### Restricted Access Vehicular Gate Operator Class IV

A vehicular gate operator (or system) intended for use in a guarded industrial location or building such as an airport security area or other restricted access locations not servicing the general public, in which unauthorized access is prevented via supervision by security personnel.

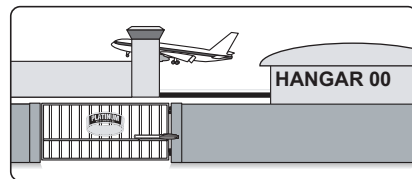

# PROTECTION AGAINST ENTRAPMENT

Usage Class	Gate Operator Category			
	Horizontal Slide, Vertical lift, and Vertical Pivot		Swing and Vertical Barrier (arm)	
	Primary Type*	Secondary Type*	Primary Type*	Secondary Type*
Vehicular I and II Vehicular III Vehicular IV	A A, B1, or B2 A, B1, B2, or D	B1, B2, or D A, B1, B2, D, or E A, B1, B2, D, or E	A, or C A, B1, B2, or C A, B1, B2, C, or D	B1, B2, C, or D A, B1, B2, C, D, or E A, B1, B2, C, D, or E

Note - The same type of device shall not be utilized for both the primary and the secondary entrapment protection means. Use of a single device to cover both the opening and closing directions is in accordance with the requirement; however, a single device is not required to cover both directions. A combination of one Type B1 for one direction and one Type B2 for the other direction is the equivalent of one device for the purpose of complying with the requirements of either the primary or secondary entrapment protection areas.

<sup>a</sup> **Entrapment protection Types:**

**Type A:** Inherent entrapment protection system.

**Type B1:** Provision for connection of, supplied with, a non-contact sensor (photoelectric sensor or the equivalent).

**Type B2:** Provision for connection of, or supplied with, a contact sensor (edge device or the equivalent)

**Type C:** Inherent adjustable clutch or pressure relief device.

**Type D:** Provision for connection of, or supplied with, an actuating device requiring continuous pressure to maintain opening or closing motion of the gate.

**Type E:** An audio alarm.

## Use and Application

### **The model ACTP715 is intended for Class I, II, III and IV usage on a vehicular slide gate application.**

- a) Install the gate operator only when:
- 1) The operator is appropriate for the construction of the gate and the usage Class of the gate,
  - 2) All openings of a horizontal slide gate are guarded or screened from the bottom of the gate to a minimum of 4 feet (1.22 m) above the ground to prevent a 2-1/4 inch (57.2 mm) diameter sphere from passing through the openings anywhere in the gate, and in that portion of the adjacent fence that the gate covers in the open position,
  - 3) All exposed pinch points are eliminated or guarded, and
  - 4) Guarding is supplied for exposed rollers.
- b) The operator is intended for installation only on gates used for vehicles. Pedestrians must be supplied with a separate access opening. The pedestrian access opening shall be designed to promote pedestrian usage. Locate the gate such that persons will not come in contact with the vehicular gate during the entire path of travel of the vehicular gate.
- c) The gate must be installed in a location so that enough clearance is supplied between the gate and adjacent structures when opening and closing to reduce the risk of entrapment. Swinging gates shall not open into public access areas.
- d) The gate must be properly installed and work freely in both directions prior to the installation of the gate operator. Do not over-tighten the operator clutch or pressure relief valve to compensate for a damaged gate.
- e) For gate operators utilizing Type D protection:
- 1) The gate operator controls must be placed so that the user has full view of the gate area when the gate is moving,
  - 2) The placard equivalent to the following: "To reduce the risk of electric shock the operator power is to be provided from a weatherproof outlet in the case of attachment plug connection or weatherproof junction box in the case of permanent wiring according to the National Electrical Code, NFPA 70." shall be placed adjacent to the controls,
  - 3) An automatic closing device (such as a timer, loop sensor, or similar device) shall not be employed, and
  - 4) No other activation device shall be connected.

## Important Safety Instructions

### WARNING – To reduce the risk of injury or death:

1. READ AND FOLLOW ALL INSTRUCTIONS.
2. Never let children operate or play with gate controls. Keep the remote control away from children.
3. Always keep people and objects away from the gate. NO ONE SHOULD CROSS THE PATH OF THE MOVING GATE.
4. Test the gate operator monthly. The gate MUST reverse on contact with a rigid object or stop when an object activates the non-contact sensors. After adjusting the force or the limit of travel, retest the gate operator. Failure to adjust and retest the gate operator properly can increase the risk of injury or death.
5. Use the emergency release only when the gate is not moving.
6. KEEP GATES PROPERLY MAINTAINED. Read the owner's manual. Have a qualified service person make repairs to gate hardware.
7. The entrance is for vehicles only. Pedestrians must use separate entrance.
8. SAVE THESE INSTRUCTIONS

## SPECIFICATIONS

Maximum Gate Weight:	700 lbs.
Maximum Gate Length:	15 feet
Opening Time:	90° opening in 21-25 seconds
Maximum Opening Angle:	120°
Power Requirements:	120 VAC Single Phase at 2 Amps or 220 VAC Single Phase at 1 Amp
Main Power:	Power Input: 100-240 VAC Select 115 /230 VAC Single Phase Built-in 24VDC battery backup (7AmpHr 12VDC x 2)
Operating Temperature:	-20°C (-4°F) to 70°C (158°F)
Arm Weight:	40 lbs.
Arm Dimensions:	

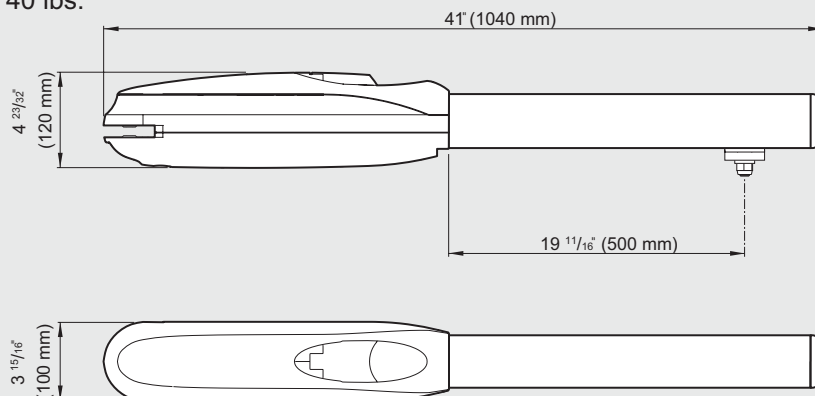

## Maintenance Instructions

**Maintenance instructions of ACTP715 performed by a qualified gate operator technician Installation, all connections, programming, repair and modifications must be done by a qualified professional gate operator installer.**

**The following services need to be periodically performed:**

- Check and adjust the gate operator for force, speed, and sensitivity.
- Make sure all power (AC/DC ) connections are corrosion free.
- Check all batteries for proper voltage of the intended use. A fully charged battery must be 26 VDC minimum.
- Check the incoming line voltage and confirm it is within 10% of its rating (115 or 230 volts).
- Verify battery backup functionally by turning off the power source (115 VAC and 230 VAC). Don't forget to restore power after testing.
- Check the wheels, guide rollers, chain, and lubricate where needed with a heavy-duty, highperformance lubricant and avoid spillage.
- Inspect the track for any signs of cracking or separation.
- Test (use caution) all contact and non-contact sensors, all vehicle detectors, keypad, telephone entry system or other control devices applicable.
- Test the manual release feature on the operator.

### Maintenance instructions of ACT715 performed by the end user/home owner

Installation, all connections, programming, repair and modifications must be done by a qualified professional gate operator installer. End users/home owners must call a qualified professional gate operator installer for programming changes, repairs and modifications.

Although all Platinum Access Systems' gate operators are virtually maintenance free to an end user/home owner minimal maintenance is recommended to ensure a smooth operation of this unit.

End users/home owners:

- Perform maintenance every six months, or when strenuous noise from wheels and/or guide rollers is detected. Lubricate them with heavy-duty, high-performance lubricant and avoid spillage.
- DO NOT take the cover off the operator and/or the electrical control box to perform maintenance.
- Make sure there are no cars in the path of the gate while performing maintenance.
- Make sure the person performing maintenance is the only person in control of all control devices in order to avoid possible involuntary activation of the gate operator.
- Keep spraying water hoses and sprinkler systems away from the gate, gate operator and the electrical control box at all times. Keep that general area as clean as humanly possible.
- Test (use caution) all non-contact sensors, all vehicle detectors, keypad, telephone entry system or other control devices applicable.

## Intended Use

The operator is intended for installation on a vehicular swing gate only.

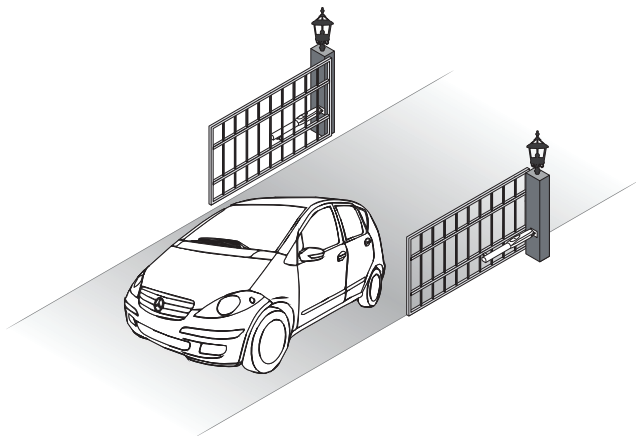

The operator IS NOT intended to be used for any pedestrian gate.



The operator IS NOT intended to be used for any uphill gate.

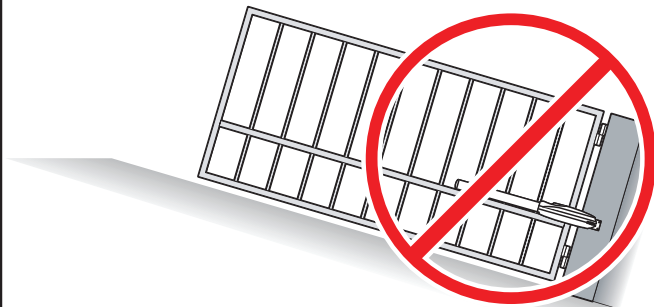

Do not attach/weld the front bracket plate to pickets directly.



# Types of Installations

## OPEN INSIDE INSTALLATION:

### Outside

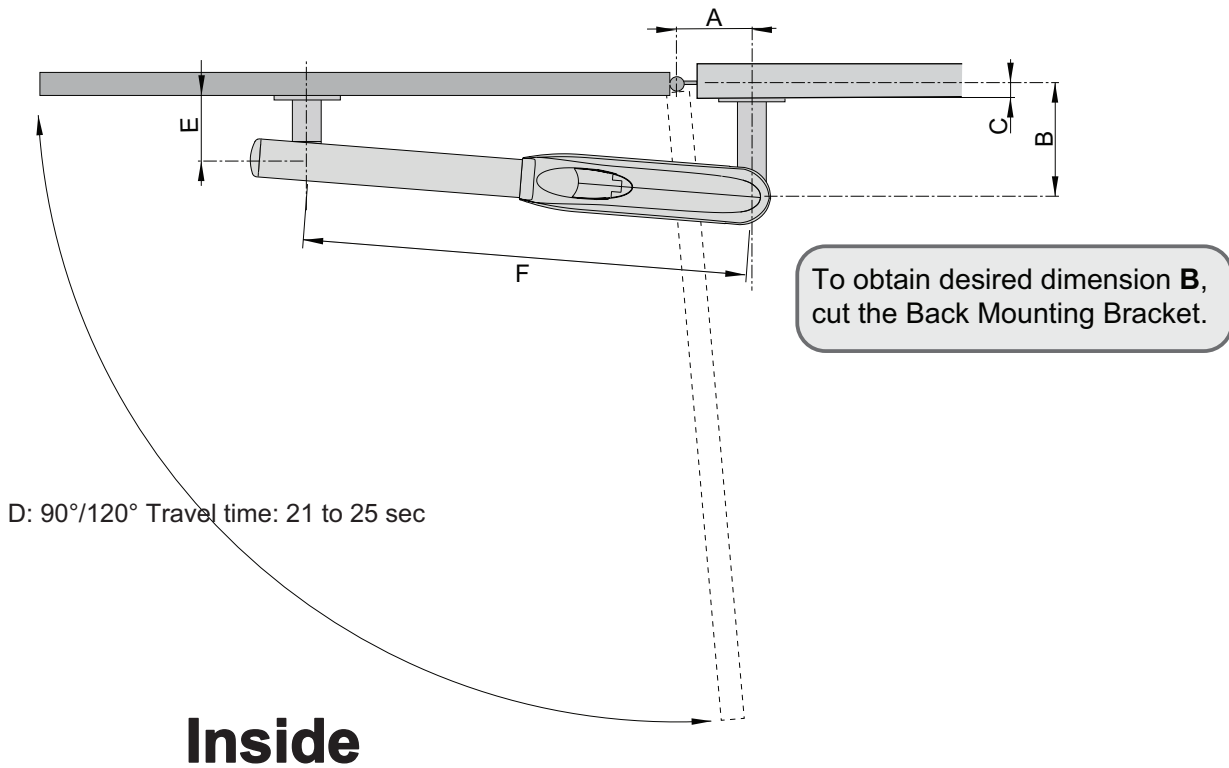

### Inside

OPEN INSIDE INSTALLATION IN inches (mm)							
A*	B*	A	B	C	D	E	F
Min 5 1/8" (130) Max 7 7/8" (200)	Min 6 11/16" (170) Max 11 7/16" (290)	6 11/16" (170)	6 11/16" (170)	3 15/16" (100)	90°	4 23/32" (120)	35 13/16" (910)
		7 7/8" (200)	7 7/8" (200)	5 1/8" (130)	95°		
		7 7/8" (200)	6 11/16" (170)	3 15/16" (100)	120°		
		5 1/8" (130)	11 7/16" (290)	8 5/8" (220)	90°		

\*Use measurements between minimum and maximum.

# Types of Installations

## OPEN OUTSIDE INSTALLATION:

To reduce the risk of entrapment leave enough clearance in between the gate and adjacent structures during opening.

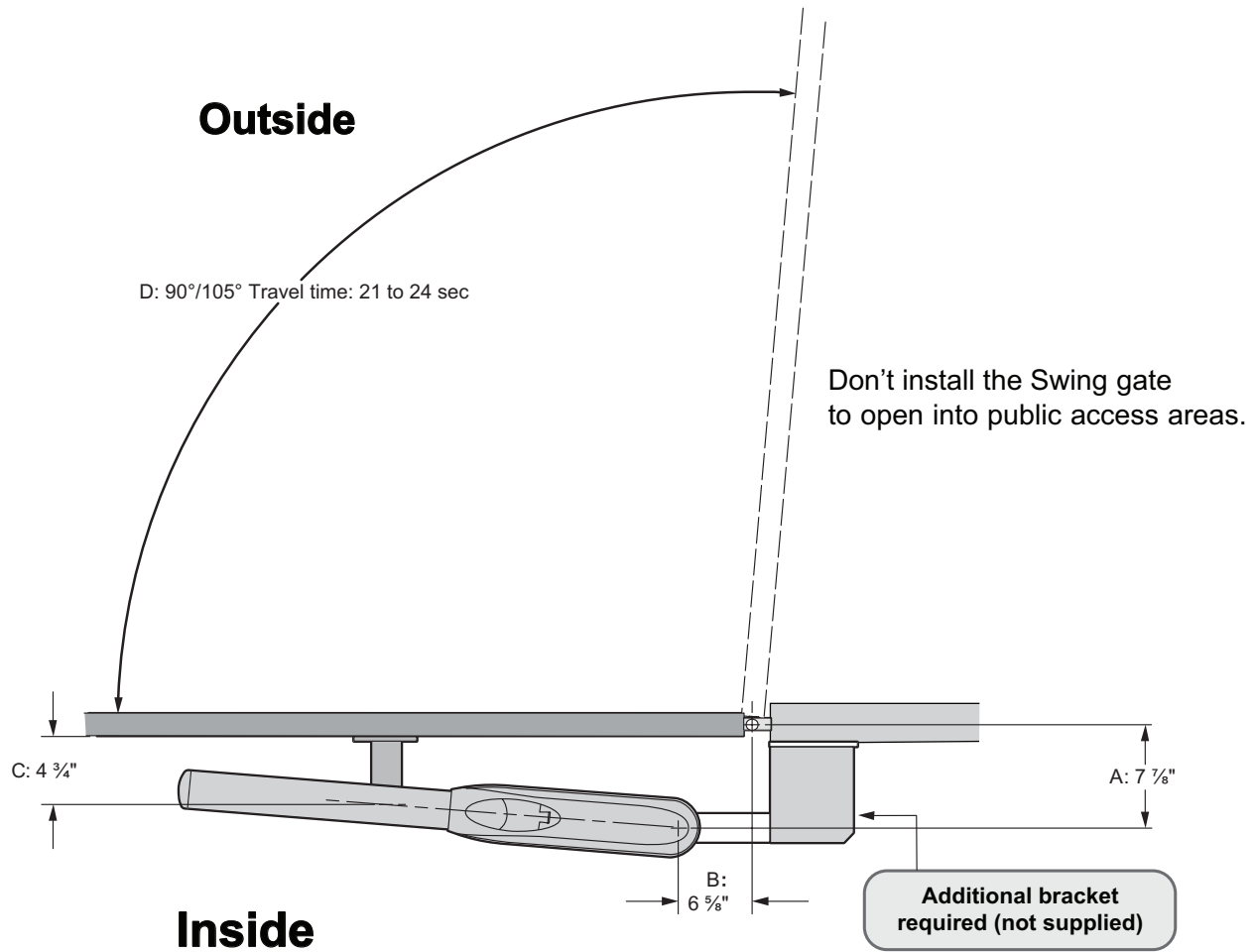

## Mounting Instructions

### CAUTION

Check that the structure is sufficiently rugged and that the hinge pivots are properly lubricated.

### STEP 1

Position Back bracket on to the pillar, check installation measurements and secure it. The installation measurements indicated in the table on page 9 allow you to choose the values of [A] and [B] on the basis of the desired opening angle and in relation to the on-site spaces and overall dimensions.

**Note:** For an open outside gate, an additional bracket will need to be fabricated to obtain the proper configuration (see figure on page 10).

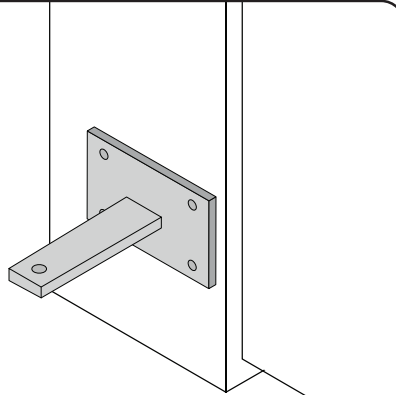

### STEP 2

Position Front bracket to the gate. Make sure Front and Back brackets are perfectly level.

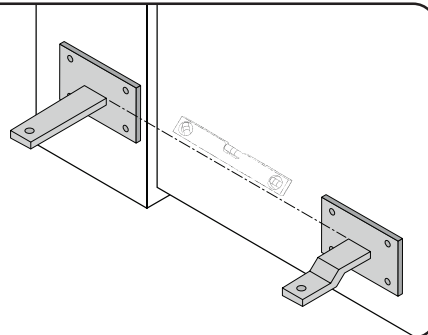

### STEP 3

Remove the Terminal Cover by opening the lock flap and removing the screw.

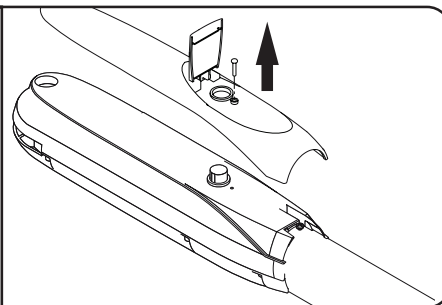

## Mounting Instructions

### STEP 4

Mount the piston on Front and Back brackets tightly screwing down the self-locking nut and lubricate the turning points.

**Note:** Pay special attention to the correct assembly of the washer on Front bracket.

Assemble and secure the drive screw cover on the drive screw using the screws provided.

**Note:** Ensure that the drive screw is properly assembled onto the screw cover head.

Manually move the gate and the gate operator to ensure the free movement throughout.

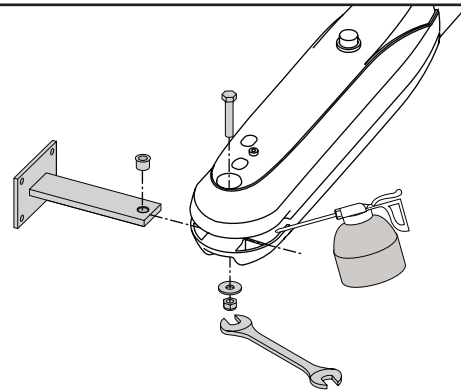
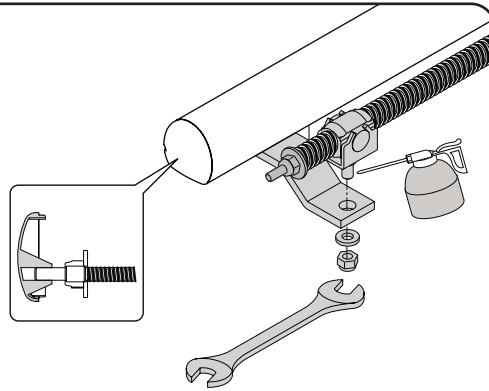

### Manual Release

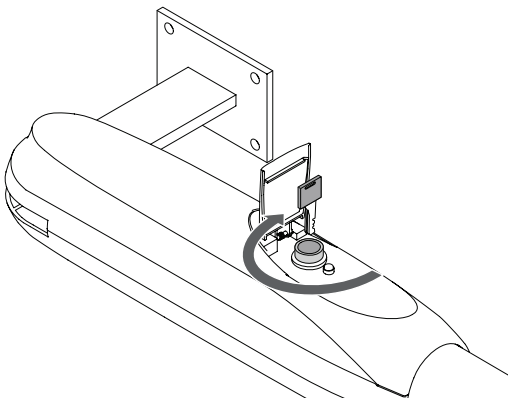

When manual operation is required:

1. Insert the key and turn it clockwise.
2. Unlock the electric lock, if mounted.
3. Manually slide the gate open.

To relock the wings:

1. Turn the key counter-clockwise.

**WARNING:** The door wing block and release operations must be performed with the motor idle.

# Mounting Instructions

**Note:** This type of installation DOES NOT reverse the gate all the way back to its limits when the sensors are obstructed. This is only to protect against entrapment and to comply with UL325.

## CONTACT SENSOR INSTALLATION:

Only sensors compliant with UL 325 are recommended.

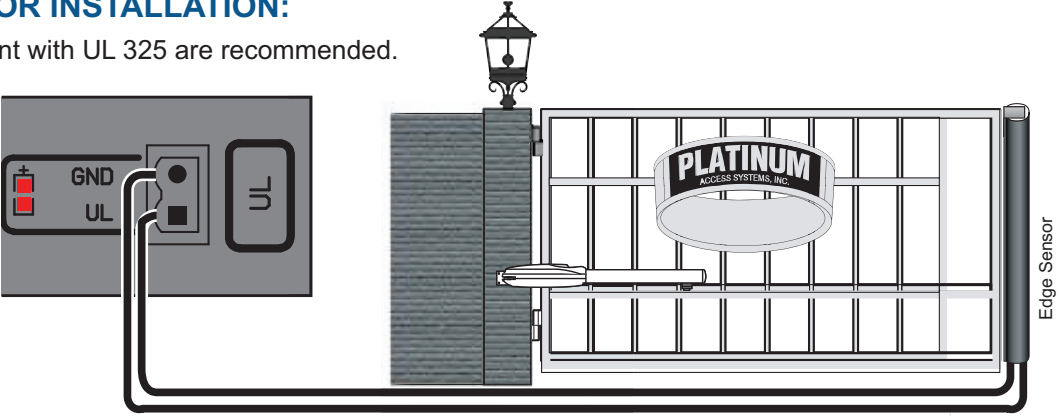

## NON-CONTACT SENSORS (PHOTOELECTRIC SENSORS) INSTALLATION:

Use one or more non-contact sensors shall be located where the risk of entrapment or obstruction exists, such as the perimeter reachable by a moving gate or barrier.

Install photoelectric sensors to protect against any entrapment or safety conditions encountered in your gate application.

We recommend the use of EMX IRB-325 photoeyes to comply with UL325.

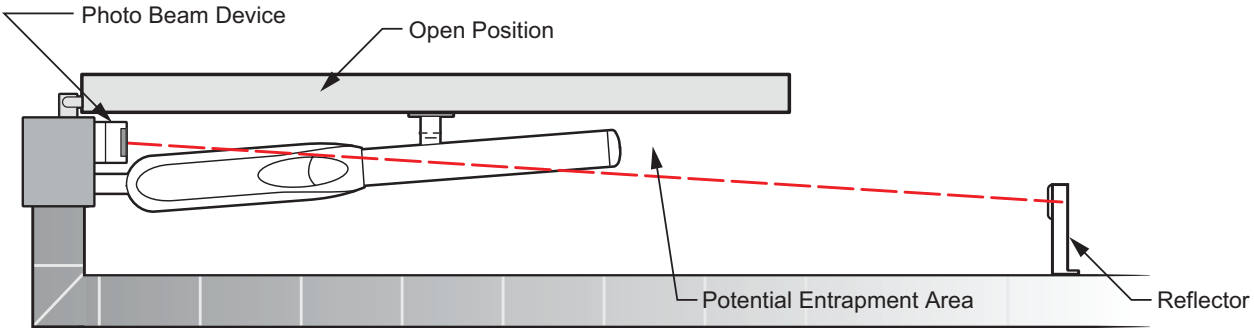
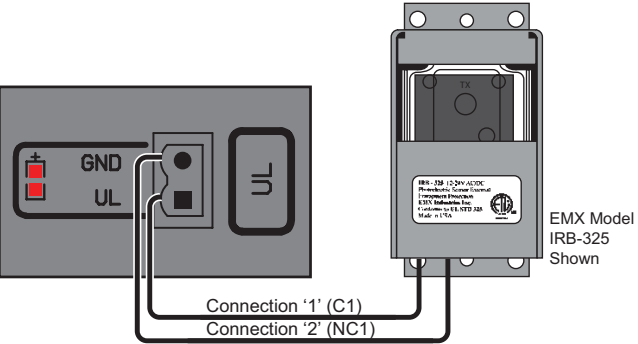

Consult the UL325 device installation manual for more detail information about the usage, installation and maintenance of this device.

# Installation: entrapment protection



**WARNING – Consult the installation instructions from the loop detector manufacturer. The following statements are provided as a guide but different requirements may be required by the vehicular loop detector manufacturer.**

Safety loops allow the gate to stay open when vehicles are on the gate path. If the gate is longer than the vehicles that pass through it a center loop is recommended and should be installed. A center loop prevents the gate from closing when a vehicle is between the safety loops. Safety loops are required when using a center loop. See Loop Wiring.

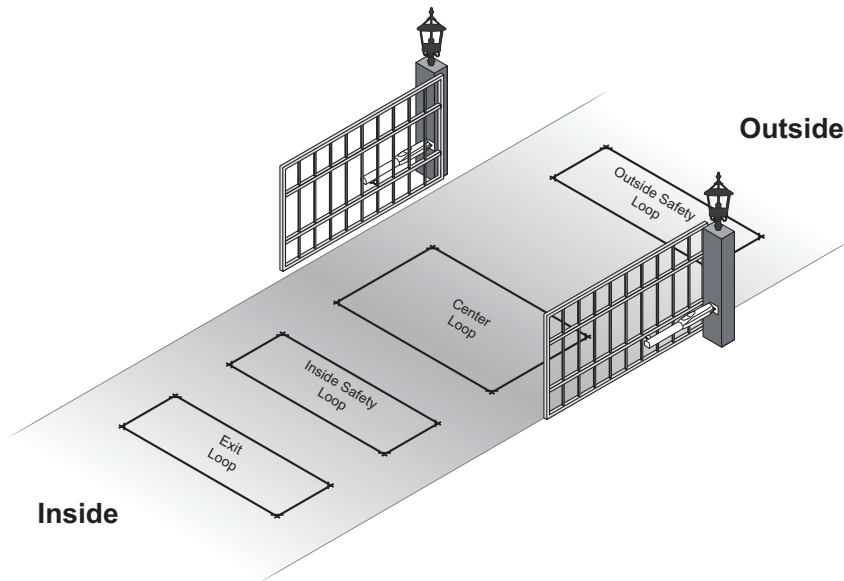

Check with local regulations and accepted best practice requirements for every installation.

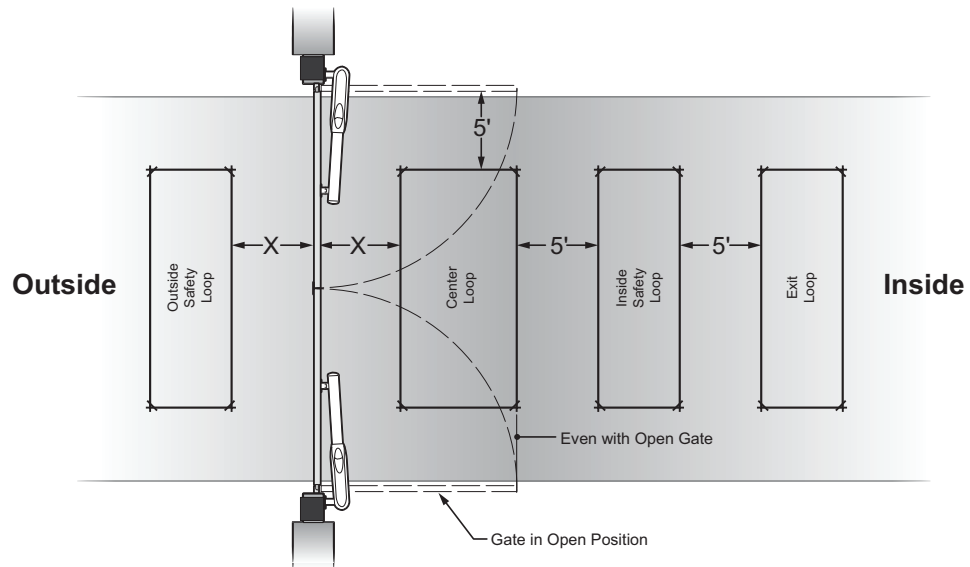

## Installation: Inductive Loops



**WARNING** – Always read and follow the manufacturer’s instructions for the products used before connecting them. Comply with all applicable codes and safety regulations. Failure to do so may result in damage, injury or death.

### New Slab Pour

Ty-wrap 1 1/4” PVC Pipe to the top of the rebar in the size and configuration of the loop (i.e. 4ft x 8ft). Then ty-wrap the loop to the top of the PVC frame. This stabilizes the loop during the pour and separates it from the rebar.

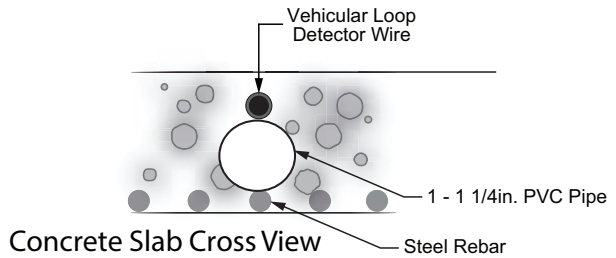

### Saw Cut Existing Surface

Cut “ deep into the existing surface, place a 45° cut at the corners to prevent sharp edges from damaging the loop wire. Notch out for the “T” connection where the lead wire connects to the loop. Remove all debris from the finished cut with compressed air. Place the loop into the saw cut. Place backer material into the saw cut over the loop wire and pack tightly. Place a high quality sealer over the saw cut to seal the surface.

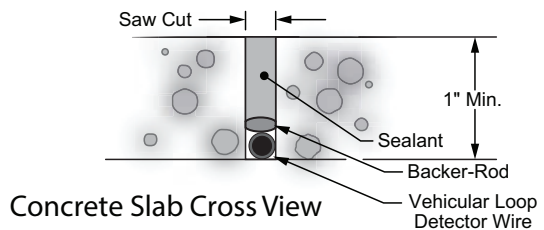

### Resurface Asphalt

Saw cut the existing surface 3/4” deep and place a 45° cut at the corners to prevent sharp edges from damaging the loop wire. Remove all debris from the finished cut with compressed air. Place sand over the loop wire to the surface and pack tightly. Lay new asphalt.

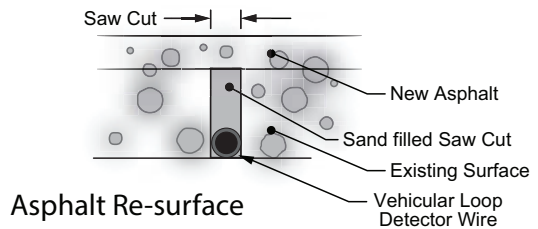

### General Installation Guidelines

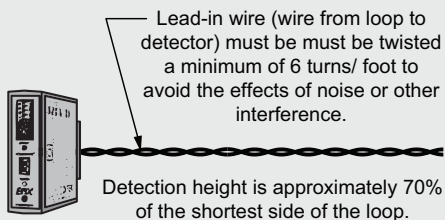

### Recommended # of Turns

Perimeter in Feet	# of Turns
10	5
20	4
30-40	3
50-100	2

## Installation: inductive loops



**WARNING – To reduce the risk of severe injury or death to person, please follow these instructions:**

### ALARM RESET SWITCH INSTALLATION: (UL 325 standard requirement)

An alarm shall signal upon two sequential activations of an entrapment protection device, where the first activation is either a Type A or B2 device and the second activation is a Type A device. The alarm shall signal for a minimum of 5 min or until a renewed manual input from an integral control or a permanently mounted control (such as a Stop button) located in the line-of-sight of the gate has been entered. An audio alarm is not required for Classes III and IV.

To reset the alarm the Stop command can be given in two different ways.

- 1- The Built in Stop switch on the control board.
- 2- The External Stop button in the line-of-sight of the gate, away from moving parts of the gate and out of reach of children.

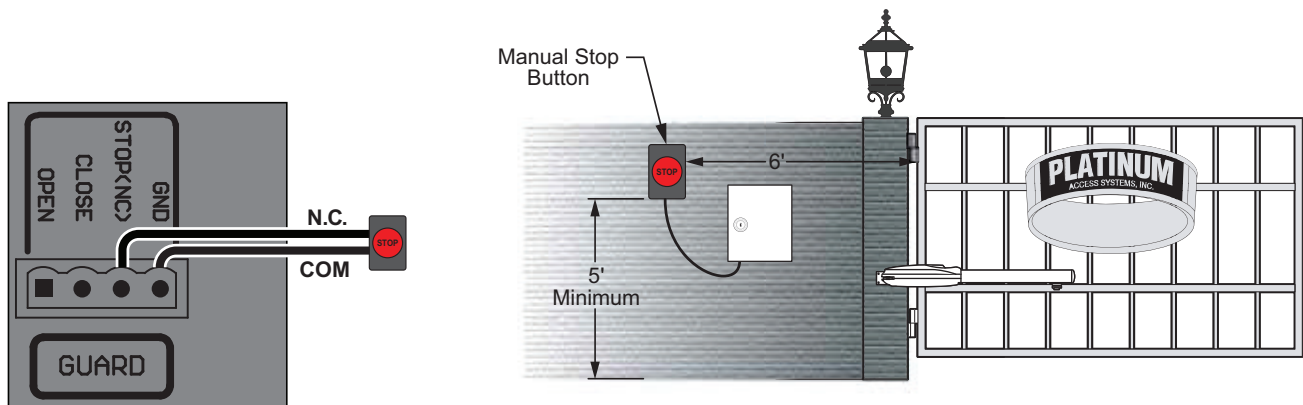

### WARNING PLACARDS INSTALLATION:

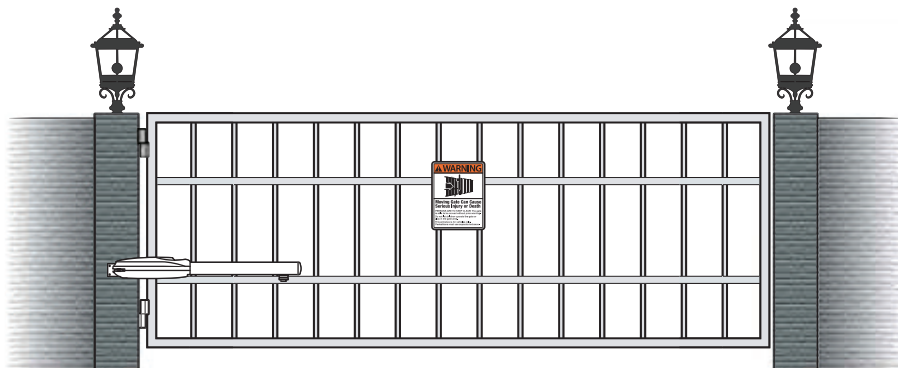

**All Warning Signs and Placards must be mounted where visible in the area of the gate.**  
A minimum of two (2) Warning Placards shall be mounted. (One on each side of the gate).

## Installation: Alarm Reset Switch & Warning Placards

The control box MUST be mounted within 5 feet of the gate operator. Mount the control box as high as possible for best radio reception. Make sure the control box is level. The control unit weight is approximately 28 lbs. with supplied batteries.

- 1.** Remove the screws and open the control box.
- 2.** Disconnect the connector from the Main Board.
- 3.** Position the control box into the desired place and mark the mounting holes.
- 4.** Select the mounting holes and remove the knockouts using a screwdriver and hammer.
- 5.** Secure the control box to mounting surface.

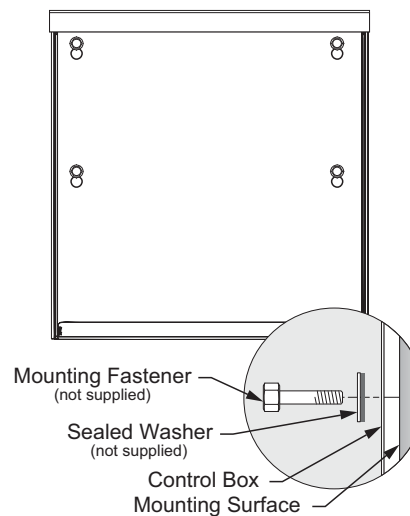
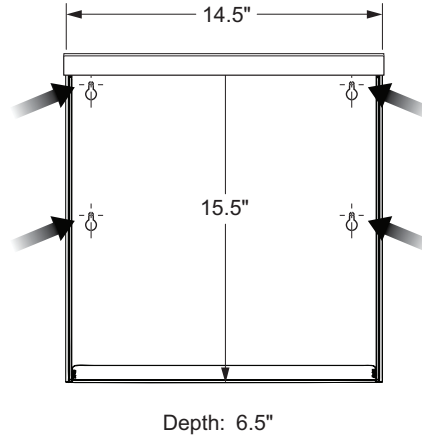
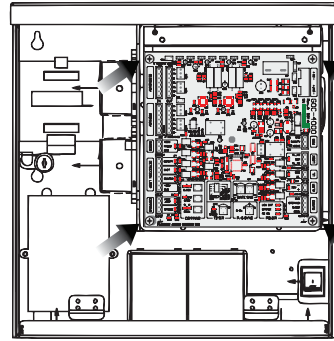

## Installation: Electrical



**WARNING – Verify the installation first to make sure everything is correct before connecting the power cable to the board. USE MIN. 14 AWG WIRE. FOLLOW ALL LOCAL ELECTRICAL CODES.**

To help protect the equipment from lightning and power surges and to protect persons from shock hazard the Operator must be grounded. The earth ground rod must be located within 3 feet from the gate operator. Use the proper type earth ground rod for your local area. The ground wire must be a single, whole piece of wire. Never splice two wires for the ground wire. If you cut the ground wire too short, break it, or destroy its integrity, replace it with a single wire length. Prevent unnecessary turns or loops in ground wires.

The gate operator and the battery charger require a single phase AC line to operate.

1. Turn off the breaker for the circuit you are using.
2. Select the proper voltage on the power board.
3. Connect the incoming power wires to the proper terminals.
4. Turn on the breaker and check that AC ON and CHARGE LED are lit.

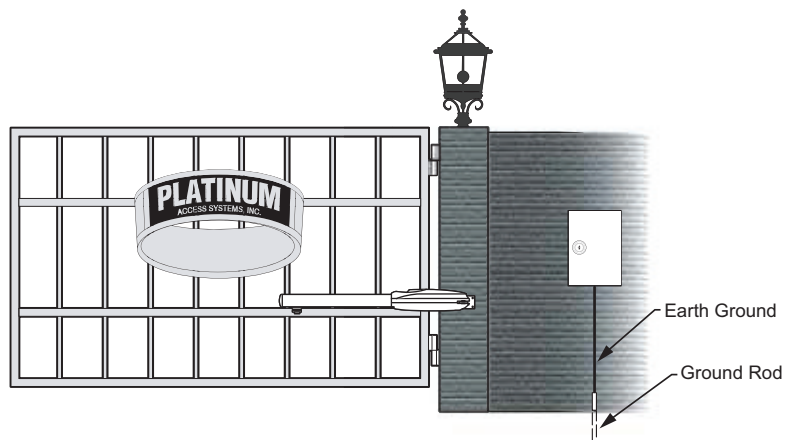
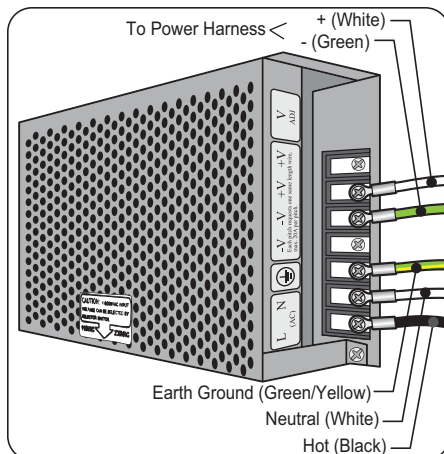
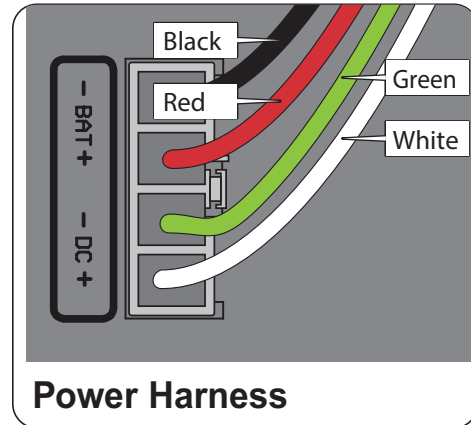

The power receptacle has been left unconnected till the installer decides what voltage to use.  
Connect to 120VAC only

# Installation: Primary Unit

## SINGLE UNIT CONNECTION:

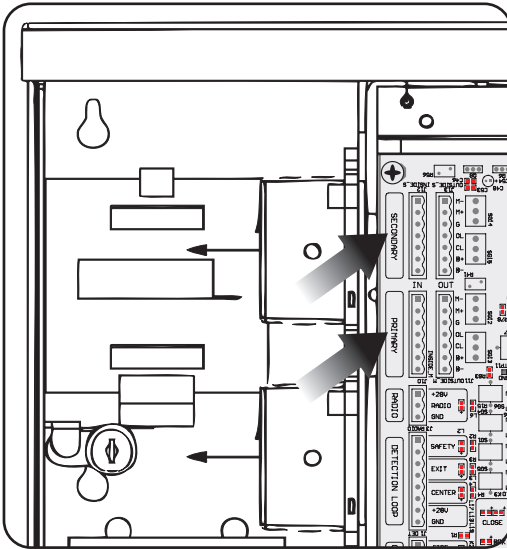

Connect the wire harness to the PRIMARY "IN" connector if the gate opens inside.

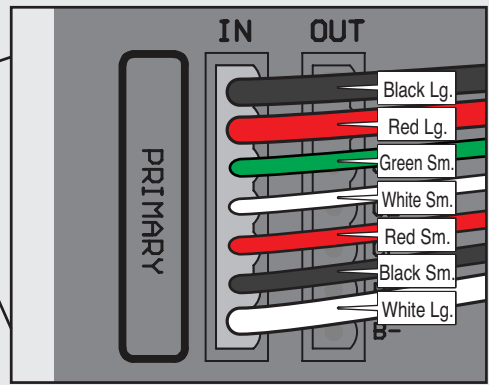
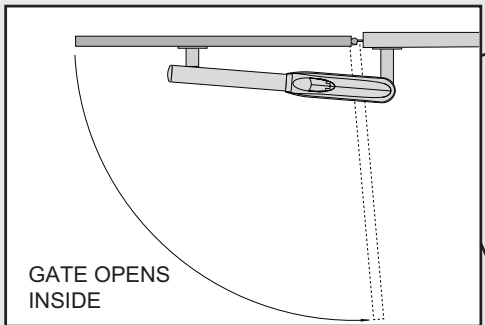

Connect the wire harness to the PRIMARY "OUT" connector if the gate opens outside.

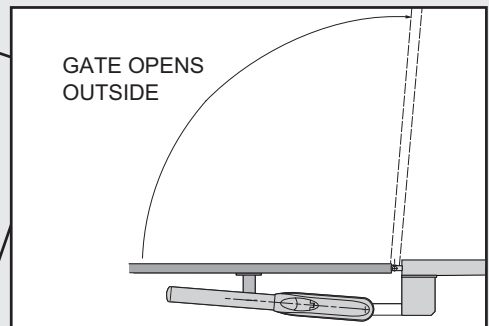
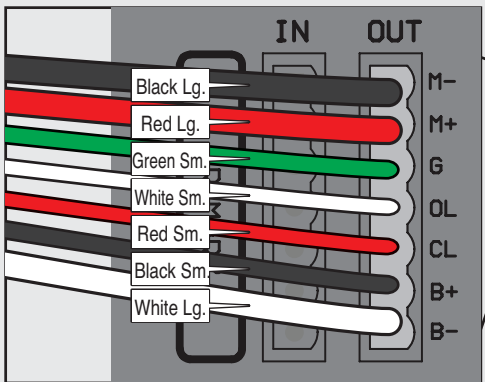

## Installation: LIMIT SWITCH SET-UP

### LIMIT SWITCH SET-UP:

#### STEP 5

Remove the screw and take the cover off by sliding out the cover.

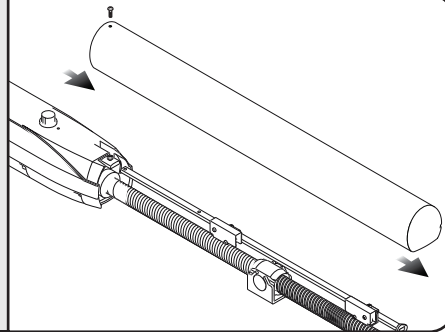

#### STEP 6

Adjust the limit switches by loosening the screws on the limit switch holder, then position the limit switches to the desired positions.

Then move the gate manually and make sure that the limit switches click at the desired open and closed positions by touching the lead screw carrier.

Tighten the screws on the limit switch holder once the proper position has been determined.

Make sure the optional Travel Limiter is at least 1/8" apart from the Close Limit Switch.

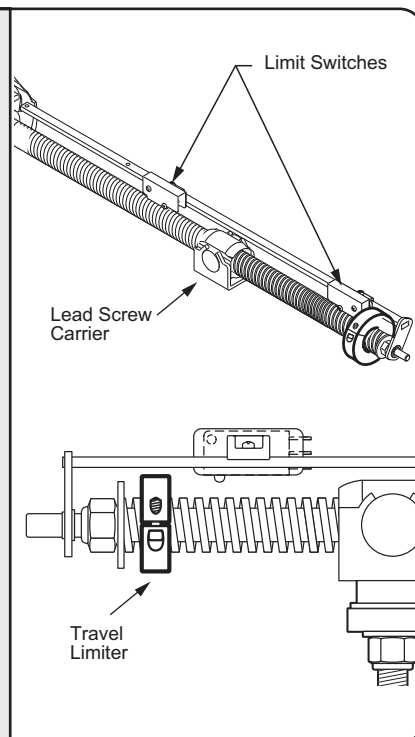

# Installation: LIMIT SWITCH SET-UP

## LIMIT SWITCH SET-UP (continued):

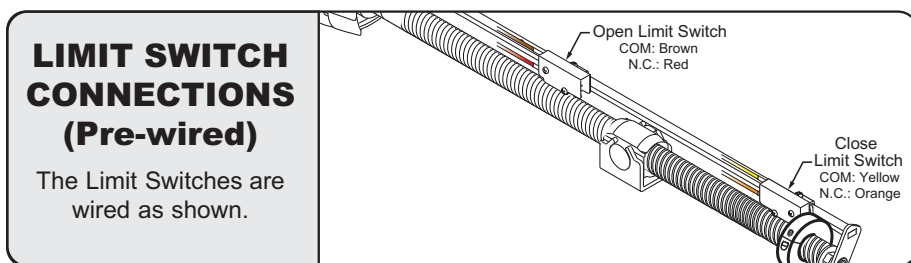
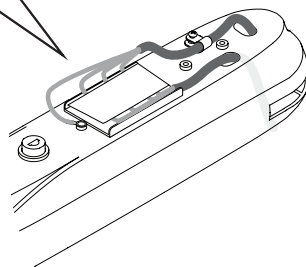
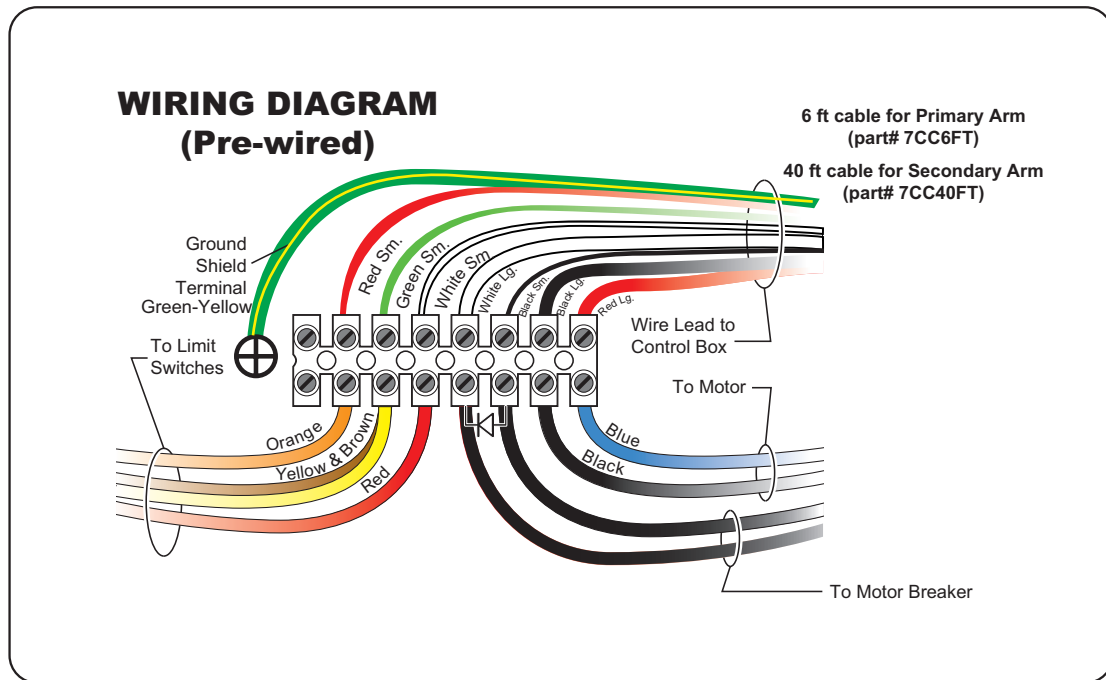

## Installation: Primary/Secondary Connections

The control board provides a connector for the secondary actuator unit and automatically synchronizes the secondary unit with the primary unit.

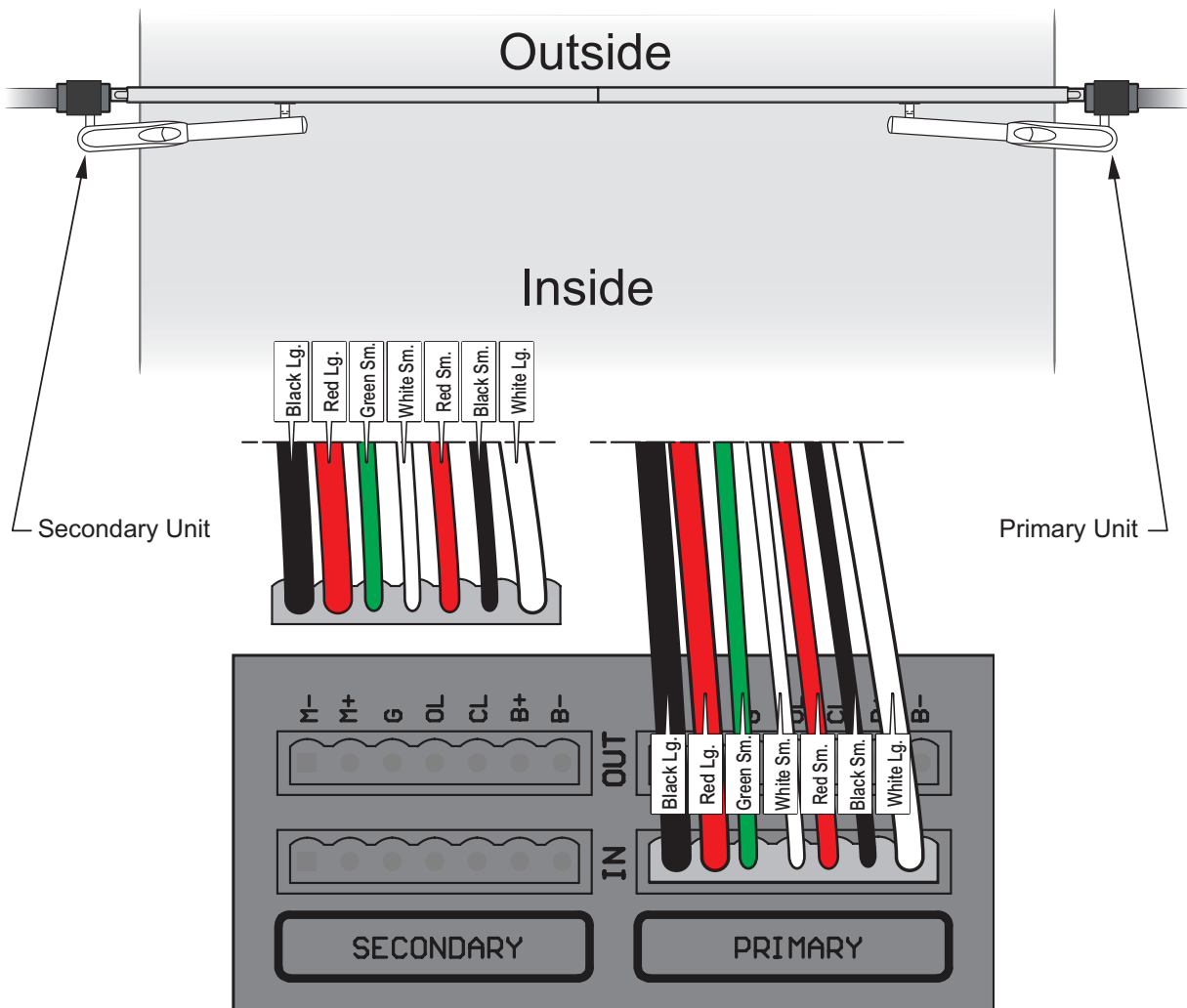

Simply connect the Secondary arm to its applicable position, IN for open inside or OUT for open outside.

# Installation: Loop Rack

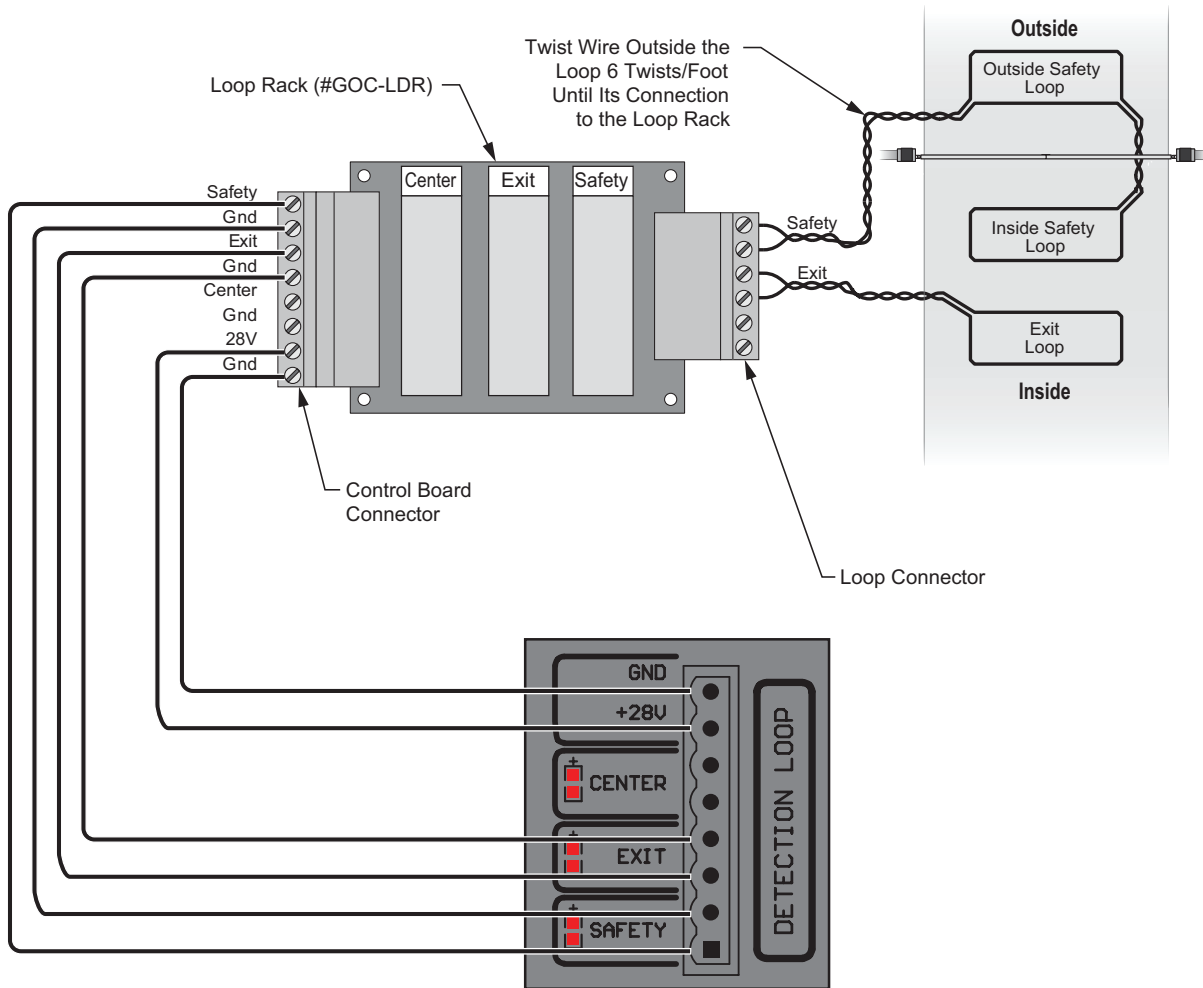

# Installation: Accessory Connections

## ACCESSORY CONNECTIONS:

To decrease the possibility of vehicle entrapment on the gate, vehicle loop detectors need to be installed. The edge sensor and the photo-electric beam can be used for secondary entrapment protection on every installation to prevent pedestrian or animal entrapment. These accessories must be UL325 compliant devices.

### Safety Connections

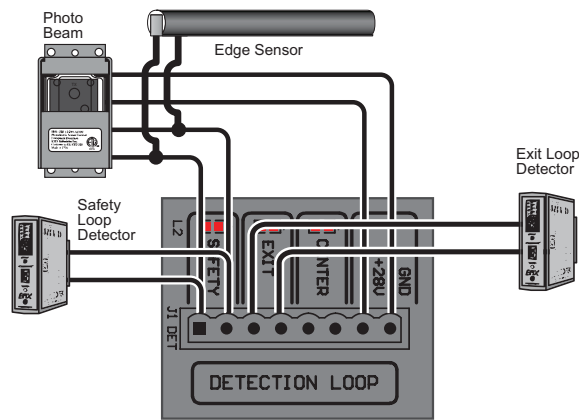

### Open Commands

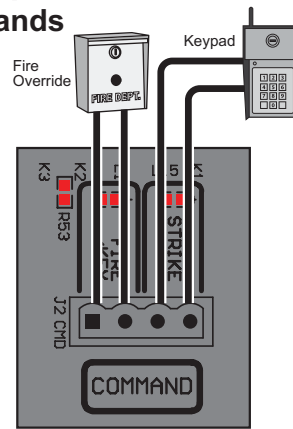

**Reopen Photo Beam**  
 Note: Installing the photo beam in this way, allows the gate to re-open all the way upon obstruction of the photo-beam.  
 The optional PBD connector provides a controlled power supply for Photo Beam. The power will be turned off when gate is in close position to save battery.

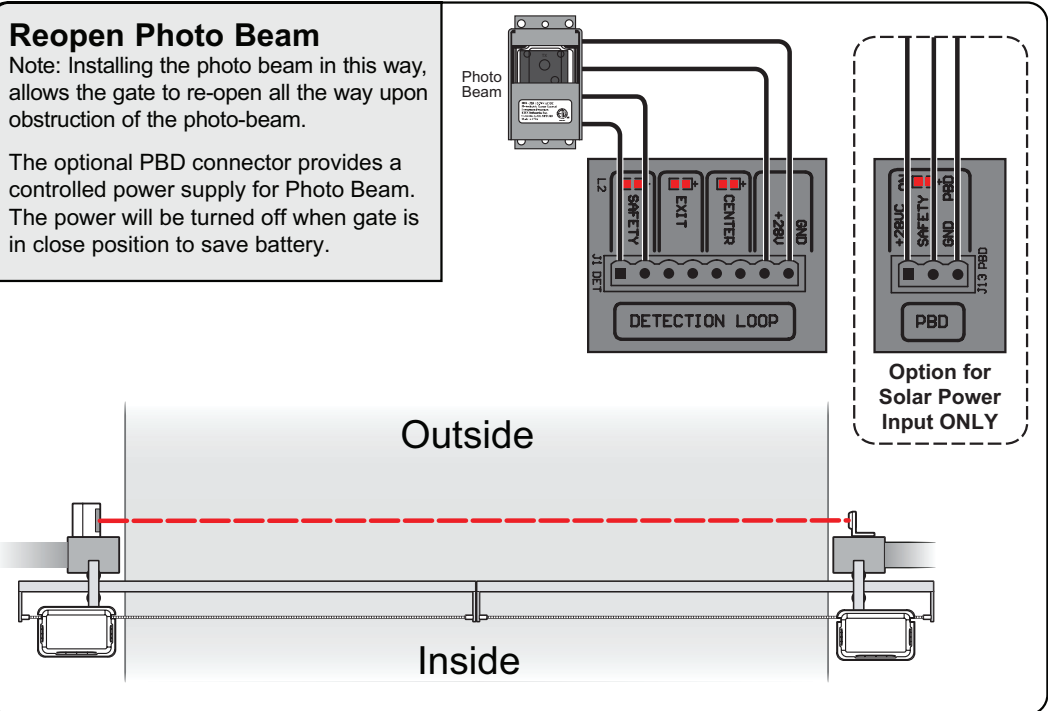

## Installation: Accessory Connections

### ACCESSORY CONNECTIONS (continued):

#### Radio Receiver

Need to verify the proper connections before connecting the Radio Receiver. The maximum voltage that the control board / battery can provide is about 28V for external accessories. If there is an electrical shot in the power to the accessories, the control board will protect itself by shutting down and will remain shut down until the short is fixed.

Two modes of operation that a radio receiver can control the gate:

##### Open-Close

By having the radio receiver connected as illustrated and with the Timer OFF:

Every command of the radio transmitter will control the gate as follow:

- A. First command opens the gate
- B. Second command CLOSE the gate if at open position
- C. Third command OPEN the gate
- D. Any subsequent commands will continue in the same order to control the gate.

*This type of configuration is not recommended for a commercial installations.*

##### Open Only

By having the radio receiver connected as illustrated and with the Timer ON:

Each command of the radio transmitter is ALWAYS AN OPEN COMMAND to the gate.

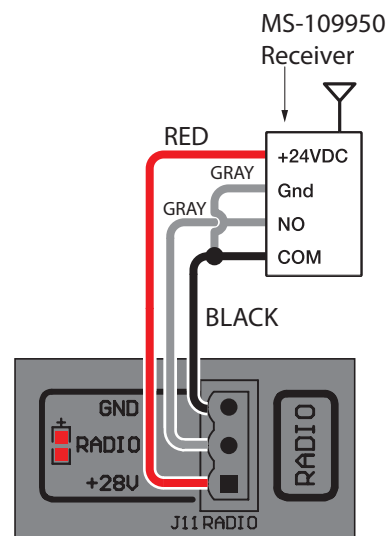

Linear MS-109950  
Installation Diagram

## Installation: Accessory Connections

### ACCESSORY CONNECTIONS (continued):

#### Solenoid Connection

The solenoid power connection must be provided an external power source. This will prevent damage to the battery in the event of a line power failure.

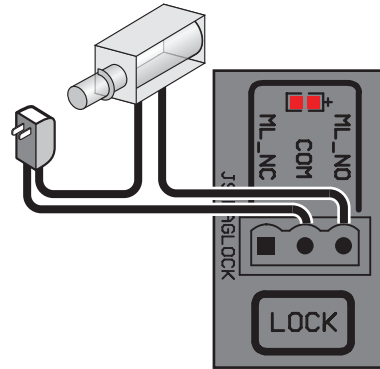

#### Guard Station

This will control the gate operator to Open, Stop, and Close the gate. The switches for Open and Close must be normally open type. The switch for Stop must be normally close type. They all can be using the same common ground. The control switch box should be within sight of the gate, out of reach of children, and away from moving parts of the gate.

If no guard station or STOP switch is installed, a jumper must be inserted between "STOP(NC)" and "GND" pins.

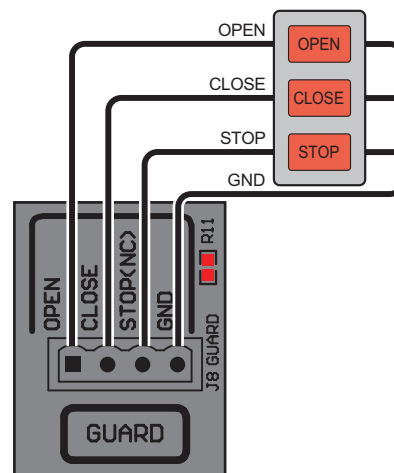

# Installation: Accessory Connections

## ACCESSORY CONNECTIONS (continued):

### Locks

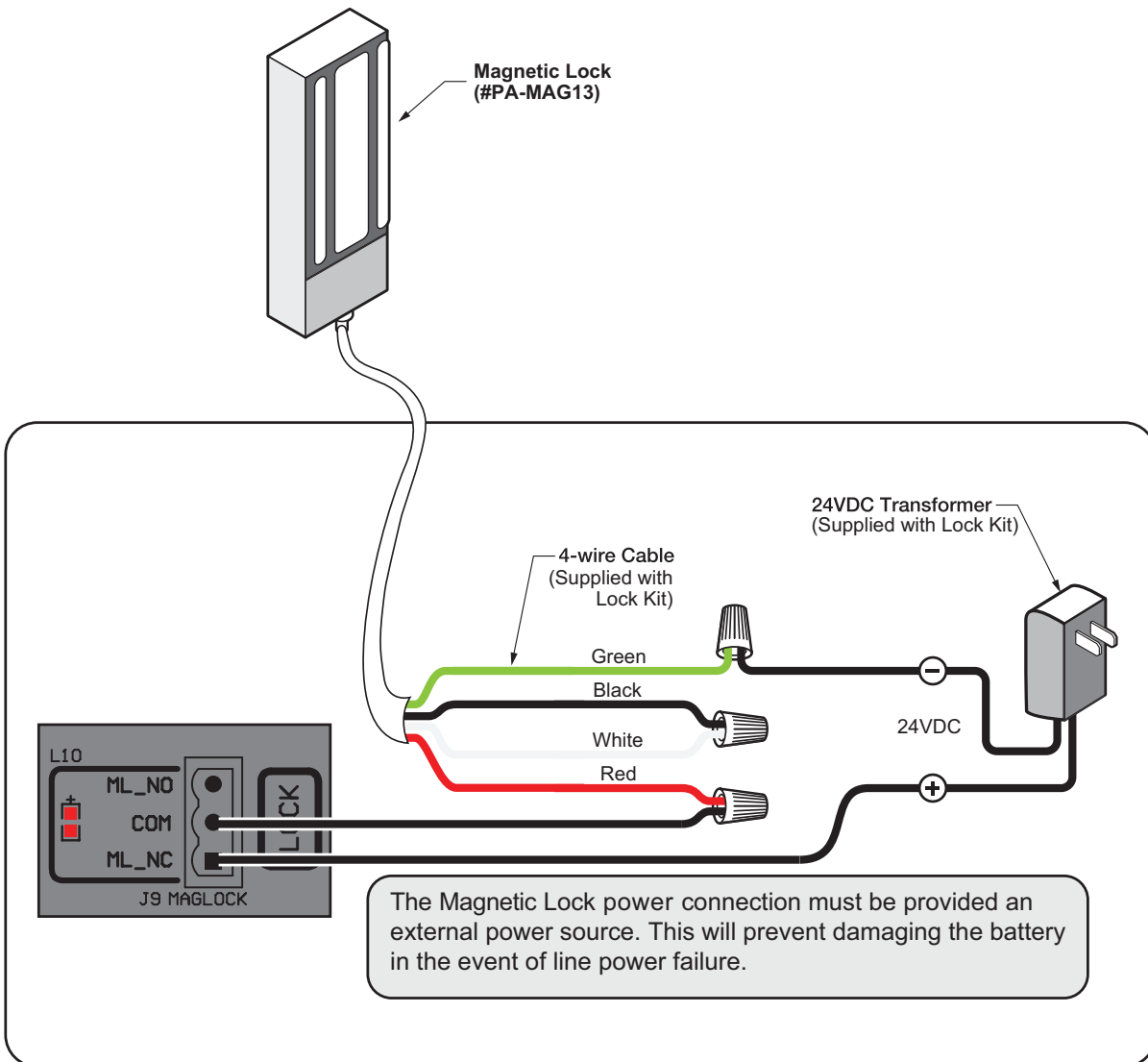

**OPTIONAL ACCESSORY- part # (PA-MAG13).**

## Installation: Selectable Features

### PRIMARY/SECONDARY OPERATOR SELECT:

#### Primary/Secondary

To set the operator to Secondary: Select the DIP switch to SECONDARY position. Recycle power to make the new setting effective.

To set the operator to Primary: Select the DIP switch to PRIMARY position. Recycle power to make the new setting effective.

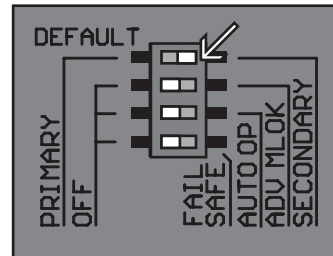

### ADVANCING LOCK SELECT:

#### ADV MLOK

To set the maglock to be engaged before the gate reaches the close or open position: Select the DIP switch to ADV MLOK position.

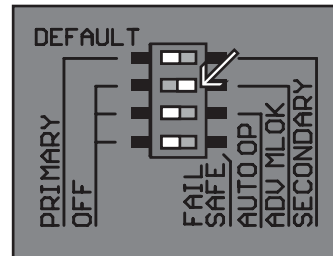

### OPEN ON POWER FAIL:

The Auto-Open feature in Platinum Access Systems Gate Operators enables the following functionality in the event of power failure:

- Open the gate in case of power failure (120 or 220 VAC).
- Keep the gate at the open position as long as there is no power.
- Resume to normal operation when the power has been restored.

All accessories and safety devices are functional. The only function disabled is the close command.

#### Auto-Open

To enable the Auto-Open feature: Select the DIP switch to AUTO OP position.

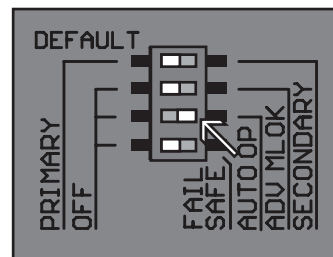

## Installation: Selectable Features

### CLOSE TIMER:

#### Close Timer

The Close Timer will close the gate a set time after the vehicle clears the gate area. This is adjustable from 3 to 60 seconds.

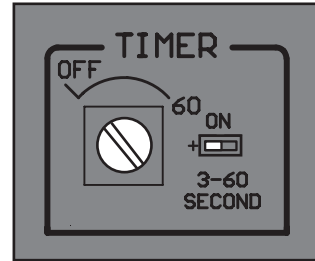

### LEAF DELAY:

#### Leaf Delay

An Overlap Delay has been provided for biparting gates that have an emblem or maglock for example. It will provide up to a 3 second delay on primary or secondary operator.

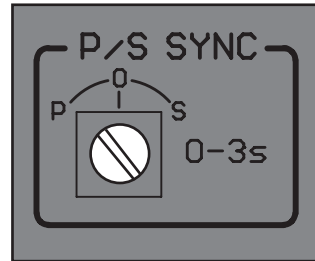

### INSTANT REVERSING SENSOR:

#### Instant Reversing Sensor

The Obstruction Sensor needs to be adjusted to compensate for the installation and gate weight. The overload adjustment is provided to set the gate sensitivity.

- If the gate reverses by itself or stops in midcycle, it is too sensitive.
- If the gate hits an object and does not reverse or stop, it is not sensitive enough.
- Clockwise increases sensitivity, counter-clockwise decreases sensitivity.

**Test and adjust for proper reversing pressure**

*(Note: When unit alarms, push "STOP" or "RESET" button will clear the alarm)*

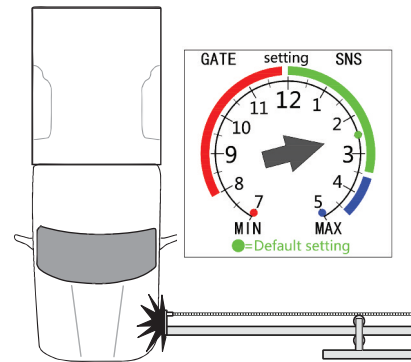
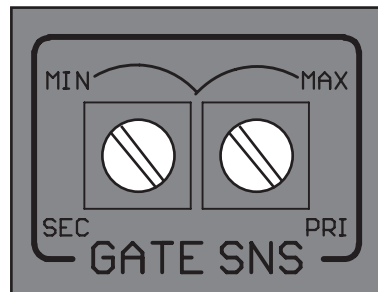

# Installation: Selectable Features & Solar Installation

## FAIL SAFE/SECURE:

### Fail Safe/Secure

On = Fail Safe  
Off = Fail Secure

Fail/Safety (Input)	Battery Detection	AC Detection	Output
ON	Normal	Normal	Secure
ON	Normal	OFF	Fail Safe
ON	Low/OFF	Normal	Fail Safe
ON	Low/OFF	OFF	Fail Safe
OFF	Normal	Normal	Secure
OFF	Normal	OFF	Fail Secure
OFF	Low/OFF	Normal	Fail Secure
OFF	Low/OFF	OFF	Fail Secure

Note: When the output is "Fail Safe", there is less resistance to push the gate open manually.

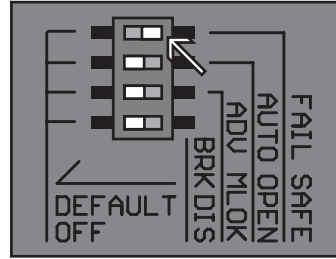

## SOLAR INSTALLATION:

### Step 1

A 24V solar panel or two 12V solar panels with minimum 80 watts capacity, Maximum Power Voltage (VPM) > 31V and Open Circuit Voltage (VOC) > 38V is required.

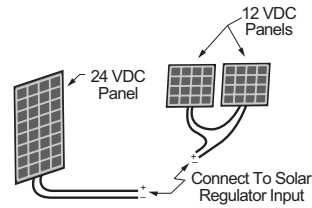

### Step 2

Connect the solar panel cables to the Solar Regulator as shown.

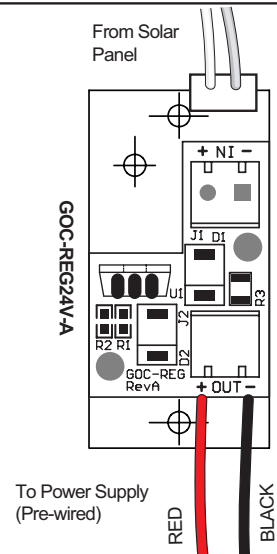

**Optional Solar Installation:** For Solar Panel controller installation, please call Technical Support.

# Parts Diagram ACTP715

- |                                                                                                                                                                                                                                                                                                                                                                                                                                                                                                                                                                                  |                                                                                                                                                                                                                                                                                                                                                                                                                                                                                                                      |
|----------------------------------------------------------------------------------------------------------------------------------------------------------------------------------------------------------------------------------------------------------------------------------------------------------------------------------------------------------------------------------------------------------------------------------------------------------------------------------------------------------------------------------------------------------------------------------|----------------------------------------------------------------------------------------------------------------------------------------------------------------------------------------------------------------------------------------------------------------------------------------------------------------------------------------------------------------------------------------------------------------------------------------------------------------------------------------------------------------------|
| <ol style="list-style-type: none"> <li>1. ECU Box (Industrial)</li> <li>2. ECU Cylinder &amp; Access</li> <li>3. Loop Detector Board</li> <li>4. Alarm</li> <li>5. Reset Switch</li> <li>6. Battery</li> <li>7. Control Board GOC-4000</li> <li>8. Control Board Bracket</li> <li>9. 7-Conductor Cable, 16 ga.</li> <li>10. Switching Power Supply</li> <li>11. Warning Placard</li> <li>12. Mounting Hardware, Back</li> <li>13. Travel Limiter</li> <li>14. Carrier, Lead Screw, with hardware</li> <li>15. Bar, Limit Switch</li> <li>16. Unit, Motor, Drive Screw</li> </ol> | <ol style="list-style-type: none"> <li>17. Holder, Cable</li> <li>18. Limit Switch (2)</li> <li>19. Limit Switch Bracket</li> <li>20. End Cap, Drive Screw Cover</li> <li>21. Dust Brush (2)</li> <li>22. Cover, Drive Screw</li> <li>23. Mounting Bracket, Back</li> <li>24. Mounting Bracket, Front</li> <li>25. Backing Plate, Bar Mount (2)</li> <li>26. Cover, Terminal</li> <li>27. Door, Access</li> <li>28. Key, Release</li> <li>29. Thumbscrew, Terminal Block Cover</li> <li>30. Power Harness</li> </ol> |
|----------------------------------------------------------------------------------------------------------------------------------------------------------------------------------------------------------------------------------------------------------------------------------------------------------------------------------------------------------------------------------------------------------------------------------------------------------------------------------------------------------------------------------------------------------------------------------|----------------------------------------------------------------------------------------------------------------------------------------------------------------------------------------------------------------------------------------------------------------------------------------------------------------------------------------------------------------------------------------------------------------------------------------------------------------------------------------------------------------------|

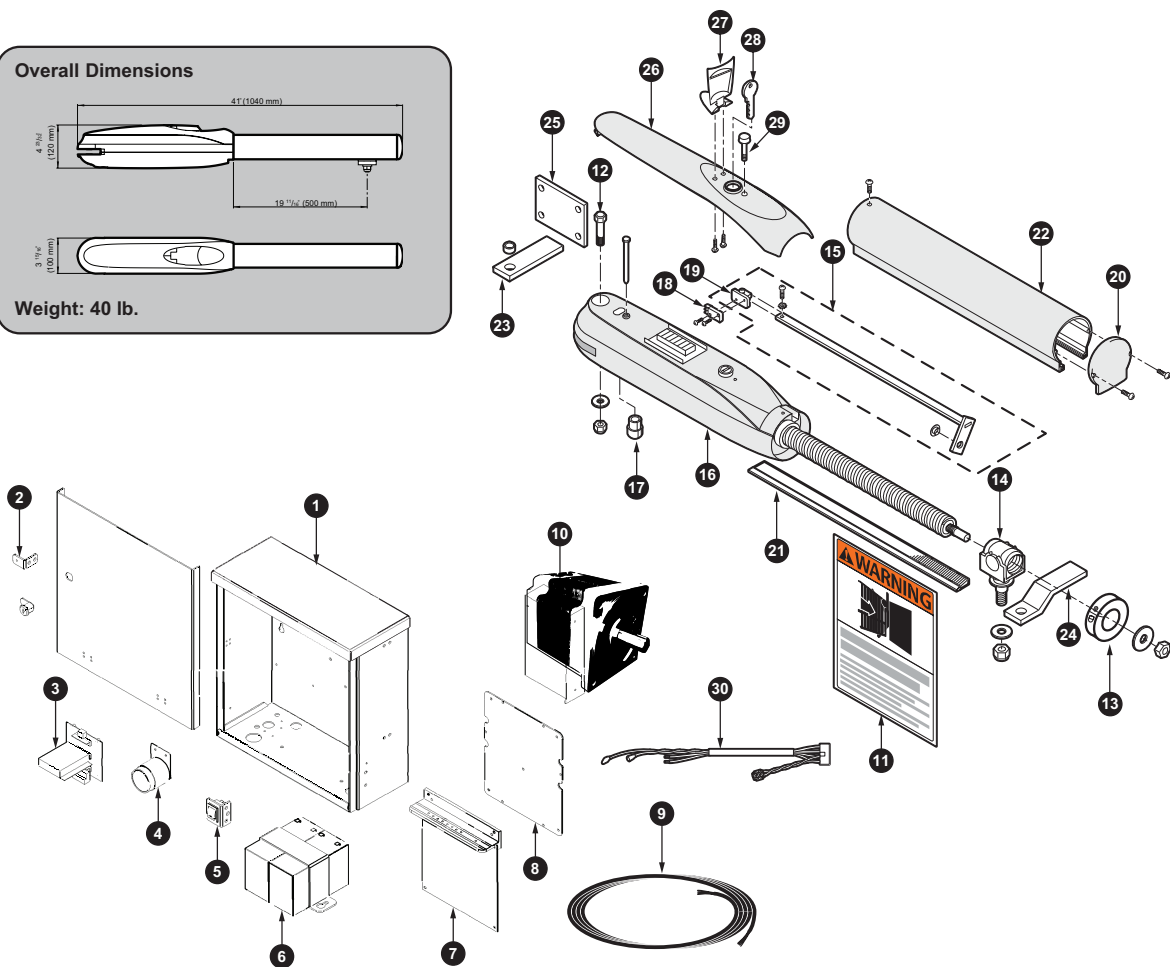
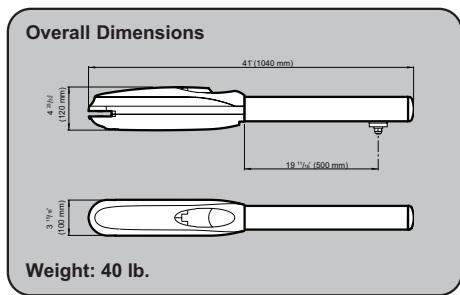

# Batteries and Power Supply

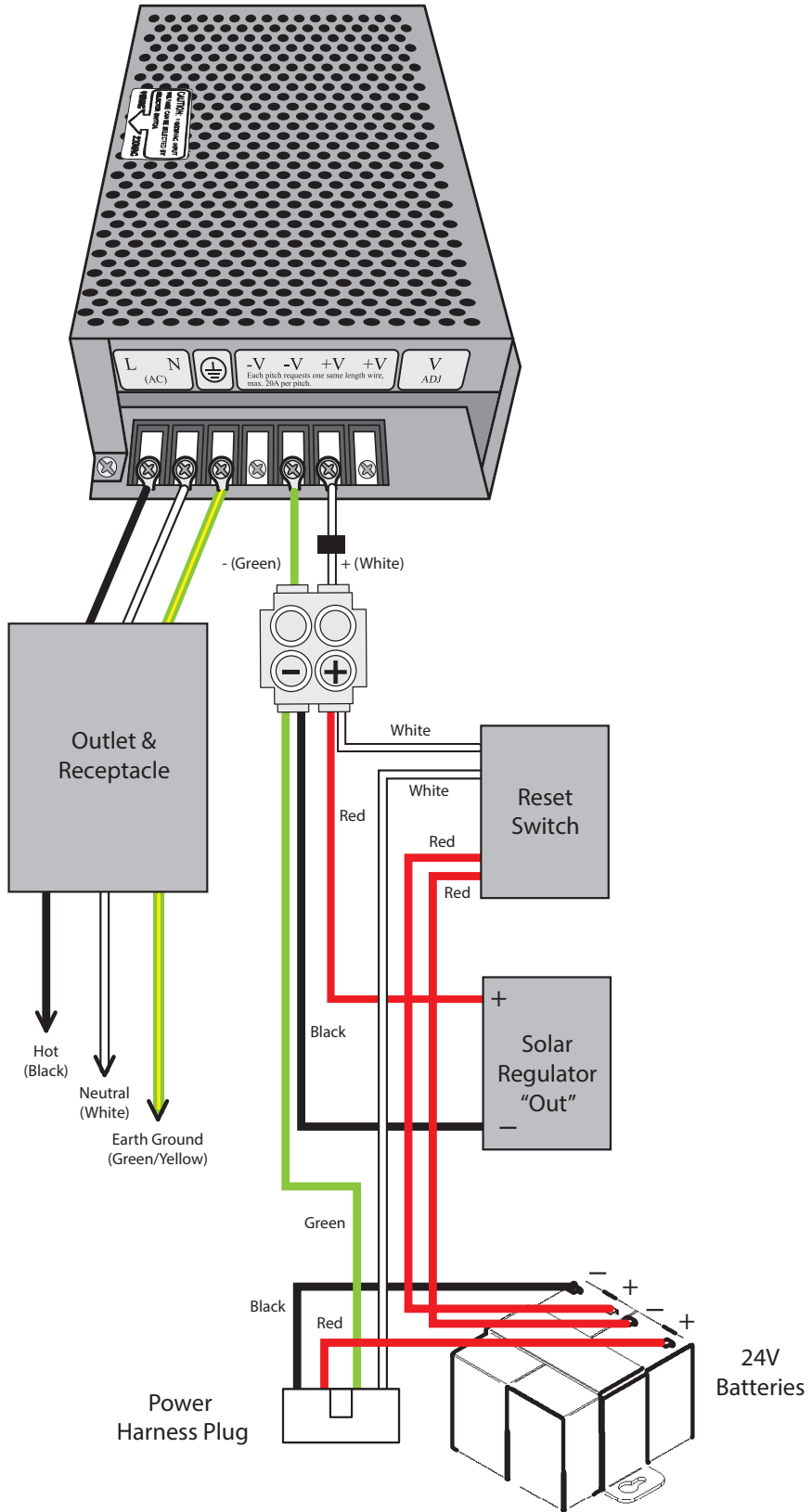







**PLATINUM ACCESS SYSTEMS™**

1725 E. Grevillea Court, Ontario, CA 91761

Phone: (855) 466-8686 | Fax: (909) 923-7890

**[www.PlatinumASI.com](http://www.PlatinumASI.com)**

© 2013 Platinum Access Systems, Inc. All Rights Reserved.

