



**SEA**  
Sistemi elettronici  
di Aperture Porte e Cancelli

SEA S.r.l.  
DIREZIONE E STABILIMENTO:  
Zona industriale 64020 S.ATTO Teramo - (ITALY)  
Tel. 0861 588341 r.a. Fax 0861 588344



<http://www.seateam.com>

e-mail: [seacom@seateam.com](mailto:seacom@seateam.com) (Uff. Comm.le)

[seatec@seateam.com](mailto:seatec@seateam.com) (Uff. Tecnico)



## INSTALLATION MANUAL

# VELA

### INSTALLATION INSTRUCTION FOR BARRIER AUTOMATION MOD. "VELA"

#### GENERAL INFORMATION

The Vela barrier is an ideal solution for controlling traffic movement in: private car parks, commercial premises, hospitals, camp-sites etc.

Fig. 1 shows the constituent parts of the Vela unit, including the pedestal casing, electro-hydraulic operator and counter sprung beam assembly.

The electro-hydraulic unit is made up of two parts:

- The anodised aluminium lower casing contains the electric motor and hydraulic pump. The pump delivery rate varies according to beam length. The electric motor is totally immersed in oil. The oil acts as a coolant and transmission medium.

- The upper part houses a piston jack that is coupled to a rack and pinion drive assembly. The central distribution flange contains the locking and pressure adjusting device. The two pressure valves allow precise adjustment of the working forces that are transmitted to the aluminium beam.

The Vela operator incorporates a hydraulic locking system that will hold and lock the beam in any position it has been stopped.

An emergency release device allows to override the locking system by using the personalised release key.

The barrier pedestal is manufactured of mild steel that has been sprayed with high gloss resin paint treatment resistant to atmospheric corrosion. The extruded aluminium beam is supplied in a white powder coated finish and fitted with reflective strips. A rubber nosing is fitted along the bottom edge to prevent damage in case of accidental contact.

The Vela barrier can be supplied with rigid aluminium beams or with a factory fitted skirt.

The Vela is suitable for left hand or right hand installations and is supplied complete with fitting accessories.

The counterbalance spring diameter is selected using the table below.

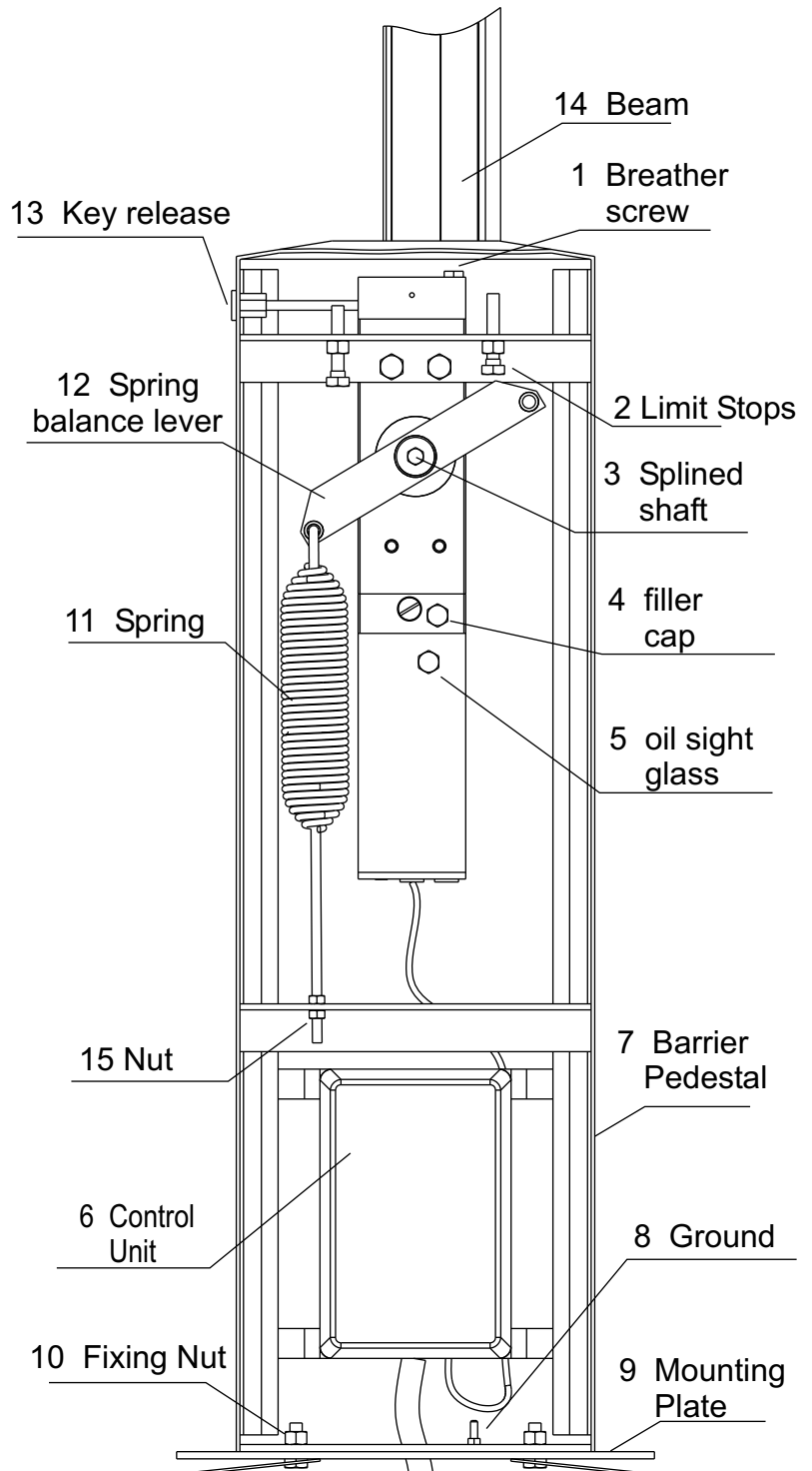
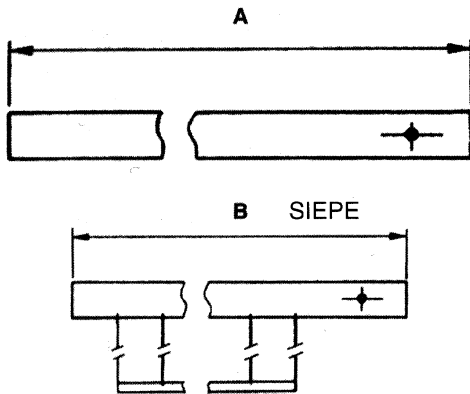

Fig. 1



## BEAM LENGTH - SPRING DIAMETER



A(m.)	Ø(mm.)
2	5,5
2,5 ÷ 3	6
3,5	6,5
4	7
4,5 ÷ 5	8

B(m.)	Ø(mm.)
2 ÷ 2,5	6
3	6,5
3,5	7
4	7,5
4,5	8,5

### TECHNICAL DATA:

Voltage	: 230V a.c. ± 10% single-phase
Motor power	: 220W
Absorbed current	: 1,1 A
Motor revolutions	: 1400 RPM/min.
Working temperature	: -25 + 80°C
Thermal intervention	: 130°C
Pump rating	: 0,75 - 1 - 1,5 2 l.
Drive torque	: 0,76 daN/BAR
Oil quantity	: 1,2 l.
Oil type	: SEA OX SUPER
Protection rating	: IP. 55
Opening times	: 3,8 s. (Pump 2 l.) : 5 s. (Pump 1,5 l.) : 7,5 s. (Pump 1 l.) : 10 s. (Pump 0,75 l.)

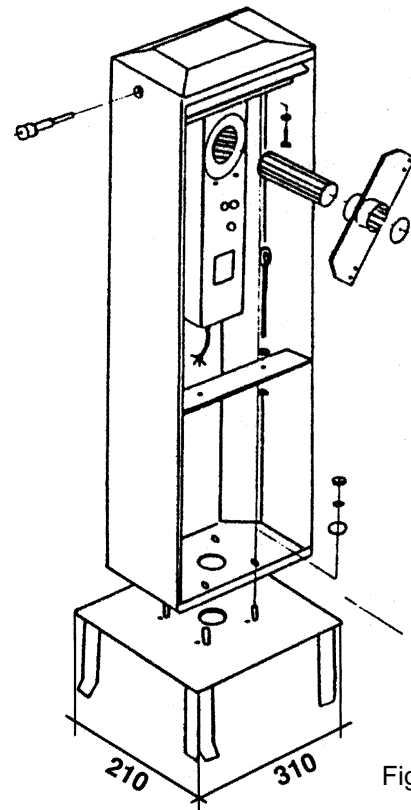

Fig. 2

### INSTALLATION

The depth and size of the foundation required for the pedestal mounting plate is dependant on the ground conditions encountered. The mounting plate should be set in a strong concrete mix (not rapid set) and must be level. Suitable cable ducts (about 40 mm. diameter) should be installed at the time of pouring the concrete foundation.

### FITTING THE BARRIER

Fix the barrier to the foundation plate using the no. 4 nuts and washers supplied with the kit.

### OPERATION OF LOCKING AND RELEASE

To move the beam manually you need to release the hydraulic locking using the release key (see Fig. 4).

Put the key into the lock cylinder and turn anti-clockwise 360° without removing.

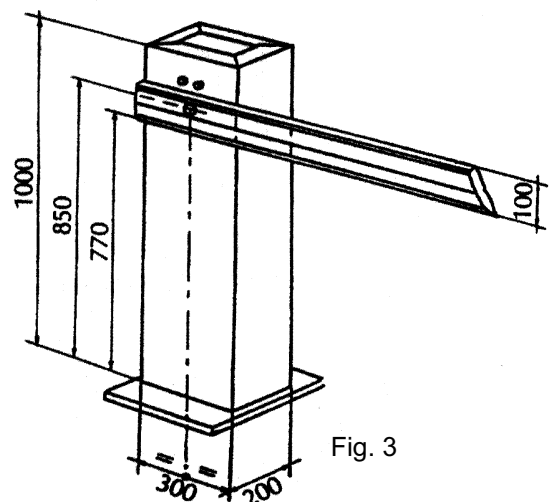

Fig. 3



## MANUAL RELEASE

The barrier is now in manual operational mode, so you can install and adjust the balance group, spring and beam.  
When you wish to re-engage the locking, turn the key fully clockwise, then return the key to vertical position and remove.

Handing the barrier to suit the installation requirement is carried out as shown in Fig. 5:

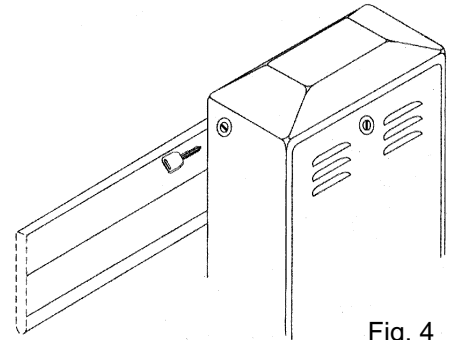
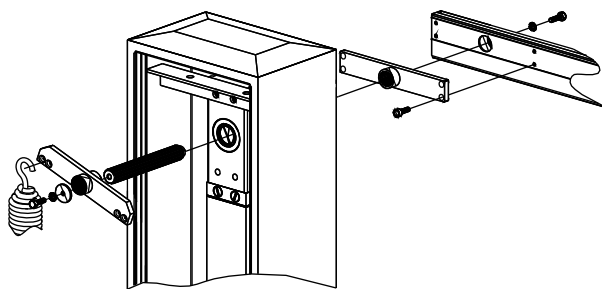
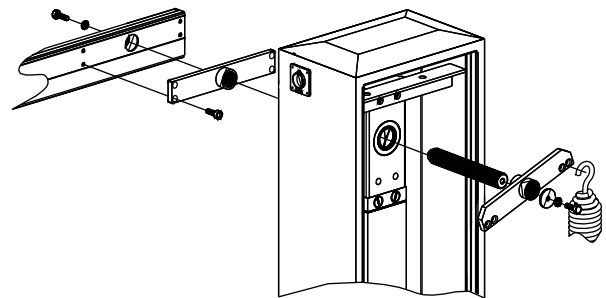

Fig. 4

## LEFT HAND MOUNTING



## RIGHT HAND MOUNTING



## ADJUSTING THE OPERATOR AND THE BALANCE LEVER

While the hydraulic block is released, operate as follows:

- Fit the splined shaft into the operator for half its length. Insert the spring balance lever in the external part of the splined shaft and turn it until the operator runs out of travel.
- Now the spring balance lever must be in a vertical position (about 15°); if not remove it and insert it again in the right position. Turn back the lever to run the operator out of travel on the other side: the balance lever must be in a vertical position. So, when the operator is in the two limit stop positions the balance lever must be as vertical as possible (15°).
- Partly fit the travel limit bolts and lock nuts (2 in Fig. 1). They will be adjusted while balancing the beam.
- Fix the balance lever to the splined shaft using the nut and washer provided.
- Move the splined shaft up to the travel stop position on the operator and turn the balance lever until it touches the travel limit bolts:
  - in a right hand installation the lever must stop on the right travel limit bolt;
  - in a left hand installation the lever must stop on the left travel limit bolt.

## FIXING THE BEAM

- Check that the external bracket mounted on the beam is in the position required; if not remove and position it in the proper working direction on the other side of the beam, using the four screws.
- Fix the beam in the splined shaft coming out from the other side of the balance lever, using nut and washer provided. To set the position of the beam adjust the travel limit bolts, previously mounted.

## INSTALLATION OF THE BALANCE SPRING

- Fit the balance spring (11 in Fig. 1) on the balance lever and spring adjusting rod (10):
  - in a right hand installation the spring must be set on the left;
  - in a left hand installation the spring must be set on the right.
- Fit the adjusting rod in the bracket provided.
- Move the beam (14) to an angle of 45° and adjust the tension of the spring using the adjusting rod..

If correctly balanced the beam should hold its position (45°) when released and the balance lever should keep a horizontal position. Now you can lock the system.

**IMPORTANT: REMOVE THE BREATHER SCREW ( 1 in Fig. 1). SUBSTITUTE THE TRANSIT OIL FILLER CAP (4) FOR THE FILLER CAP WITH A BREATHER HOLE WHICH IS SUPPLIED WITH THE KIT**

## PRESSURE REGULATION

Set the working forces using the pressure valves on the side of the operator Turn clockwise to increase the pressure, turn anticlockwise to decrease. Remember to switch off the mains supply when adjusting the pressure valves. When supplied, the unit is calibrated on 15 Kg max. for safety standard.

Fully test the system and check that all nuts and bolts are tight. Do not forget to fit the self-adhesive reflective strip across the outside part of the beam.

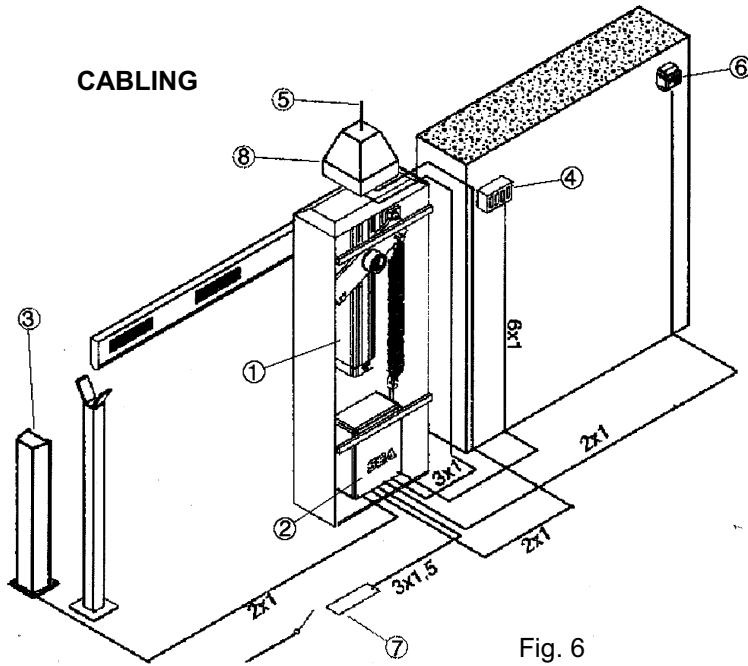

1	Operator
2	Electronic control unit
3	Photocell
4	Push button
5	Radio receiver
6	Key digital switch
7	16A - 0.030A Differential Switch
8	Warning flashing light

Fig. 6

#### SAFETY PRECAUTIONS

All electrical work should conform to current regulations. A 16A 0,030A differential switch must be incorporated into the source of the operators main electrical supply and the entire system properly earth bonded. Always run mains carrying cables in separate ducts to low voltage control cables to prevent mains interference.

#### SPARE PARTS

To obtain spare parts contact: **SEA s.r.l. ZONA Ind.le, 64020 S.ATTO Teramo Italia.**

#### INTENDED USE

The Vela operator has been designed to be solely used for the automation of traffic barriers.

#### SAFETY AND ENVIRONMENTAL COMPATIBILITY

We recommend not to spoil the environment with product and circuit packing material.

#### CONFORMITY REQUIREMENTS

The Vela operator conforms to the following:

- 89/392/CEE (Machine Directive)
- 89/336/CEE (Electromagnetic Compatibility Directive)
- 73/23/CEE (Electric Safety)

#### STORAGE

STORAGE TEMPERATURES			
T <sub>min</sub>	T <sub>max</sub>	Humidity <sub>min</sub>	Humidity <sub>max</sub>
-40°C	+85°C	5% no condensation	90% no condensation

When being transported this product must be properly packaged and handled with care.

#### MAINTENANCE AND OUT OF SERVICE

The decommission and maintenance of this unit must only be carried out by specialised and authorised personnel.

#### LIMIT OF GUARANTEE

The Vela operator is guaranteed for a period of 24 months. The guarantee period starts from the date stamp printed on the unit. The Vela guarantee will be void if the unit has been incorrectly installed, not used for the purpose intended, tampered with or modified in any way. The validity of this guarantee only extends to the original purchaser of the unit.

**NOTE: THE MANUFACTURER CAN NOT BE DEEMED RESPONSIBLE FOR ANY DAMAGE OR INJURY CAUSED BY IMPROPER USE OF THIS PRODUCT.**

*SEA reserves the right to do changes or variations that may be necessary to its products with no obligation to notice.*