

PowerMaster

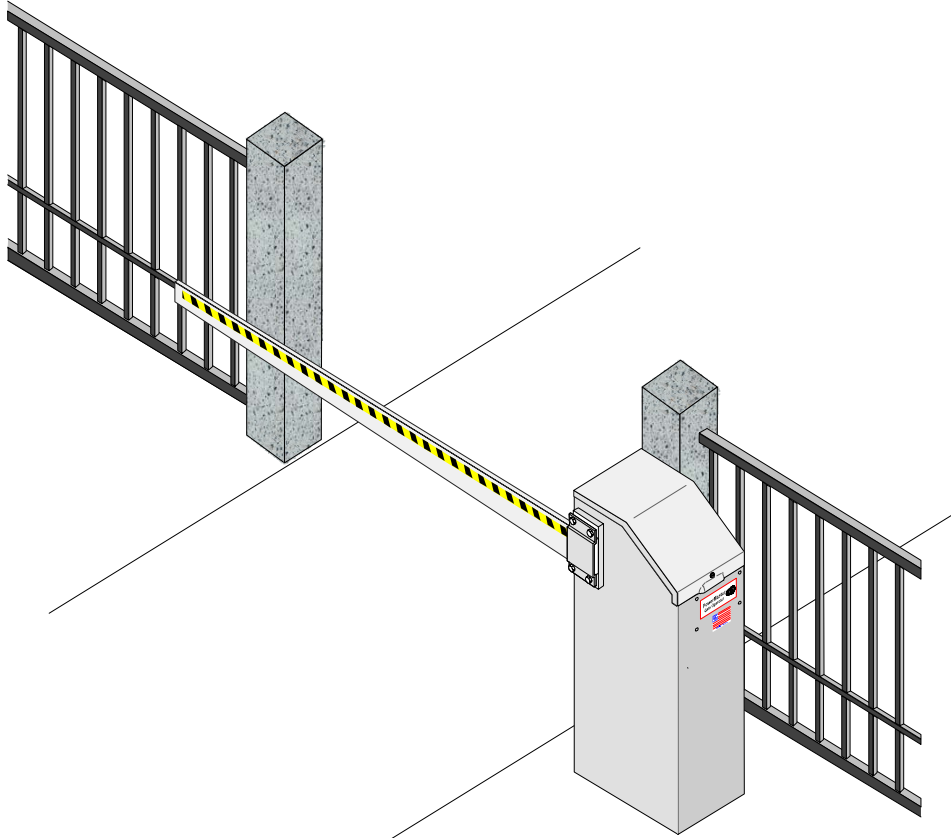

Installation Manual SBG OPERATOR

SINGLE ARM BARRIER GATE OPERATOR

UL 325 AND UL 991 LISTED



TABLE OF CONTENTS

MODEL “SBG” SINGLE ARM BARRIER GATE OPERATOR

Important Safety Information.....	3
System Designer Safety Instructions.....	4
Installer Safety Instructions	5
End User Safety Warnings	8-10
Installation & Setup Procedure	
Before Installing Operator.....	11
Installation of Cement Pad.....	12
Installation of Operator.....	13-14
Installation of Barrier Arm.....	15-16
Electrical Connections.....	16-17
Clutch Adjustment.....	18
Manual Operation.....	19
Limit Adjustment Procedure	19-20
Accessory Connections	
Connection of a 2 Button.....	21
Connection of a 1 Button.....	21
Connection of a Radio.....	22
Timer To Close.....	23
External Timer Defeat Switch	24
Auxiliary Limit Switch	24
Master/Slave Operation.....	25-27
Installation of Edge Sensor or Photo Eyes.....	28
Loop Detector Systems and Installation	
Loop Layout Diagram.....	29
Standard Loop Layout Size Chart.....	30
Loop Installation.....	30
Cutting The Required Groove.....	31
Loop Detector Connections.....	32-34
Barcon Board Overview.....	35
Wiring Diagram.....	36
Notes/Maintenance Log.....	37
Warranty.....	38

IMPORTANT!

FOR BARRIER GATE OPERATING SYSTEMS

SAFETY IS EVERYONE'S BUSINESS

Automatic gate operators provide convenience and security to users. However, because these machines can produce high levels of force, it is important that all gate operator system designers, installers, and end users be aware of the potential hazards associated with improperly designed, installed, or maintained systems. Keep in mind that the gate operator is a component part of a total gate operating system.

The following information contains various safety precautions and warnings for the system designer, installer and end user. These instructions provide an overview of the importance of safe design, installation, and use.

Warnings are identified with the ▲ symbol. This symbol will identify some of the conditions that can result in serious injury or death. Take time to carefully read and follow these precautions and other important information provided to help ensure safe system design, installation and use.

▲ **WARNING:** Gate operators are only one part of a **TOTAL GATE OPERATING SYSTEM**. It is the responsibility of purchaser, designer, and installer to ensure that the total system is safe for its intended use. All secondary entrapment safety devices must be **RECOGNIZED** by **U/L** to ensure the safety of the complete operating system.

SYSTEM DESIGNER SAFETY INSTRUCTIONS

- ▲ 1. Familiarize yourself with the precautions and warnings for the installer. Users are relying on your design to provide a safe installation. The installation should have an entrapment protection system installed such as photoelectric sensors or an electric edge.
- ▲ 2. When designing a system that will be entered from a highway or main thoroughfare be sure the system is placed far enough away from the road to eliminate traffic backup. Distance from the road, size of the gate, usage levels, and gate cycle/speed must be considered to eliminate potential traffic hazards.
- ▲ 3. Design the gate system so a person cannot be trapped between the arm and any other fixed structure. All rigid objects must be at least 2 feet from gate arm.

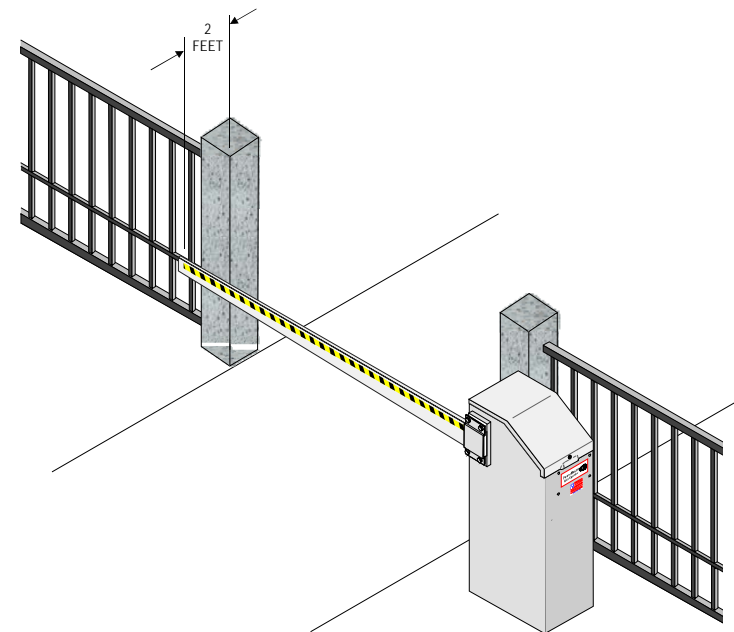

INSTALLER SAFETY INSTRUCTIONS

BEFORE INSTALLATION

- ▲ 1. Check to see that the operator is proper for this type and size of opening and its frequency of use. If you are not sure, consult factory.
- ▲ 2. Check to see that there are no structures adjacent to the area, which may pose a risk of entrapment when gate is opening or closing.
- ▲ 3. Safety equipment such as electric edges or photocell sensors must be installed to provide personnel, equipment, and property protection. For assistance in selecting the correct type of safety equipment, consult the factory.
- ▲ 4. You must install a pushbutton control or key switch to allow for normal operation of the gate if the automatic controls do not work. Locate the pushbutton or key switch and small warning placard within sight of the gate in a secured area at least 10 feet or more from the gate and fence to keep users away from the moving gate and fence.
- ▲ 5. Outdoor or easily accessed gate controls should be of the security type to prohibit unauthorized use.

DURING INSTALLATION

- ▲ 1. Be aware of all moving parts and avoid close proximity to any pinch points.
- ▲ 2. Disconnect power at the control panel before making any electric service connections. Connection location for controls and safety equipment can be found on the wiring diagram, and in this manual.
- ▲ 3. Locate the controls at least 10 feet from the moving gate so that the user can observe the gate operation, but is not able to come in contact with the gate while operating the controls.

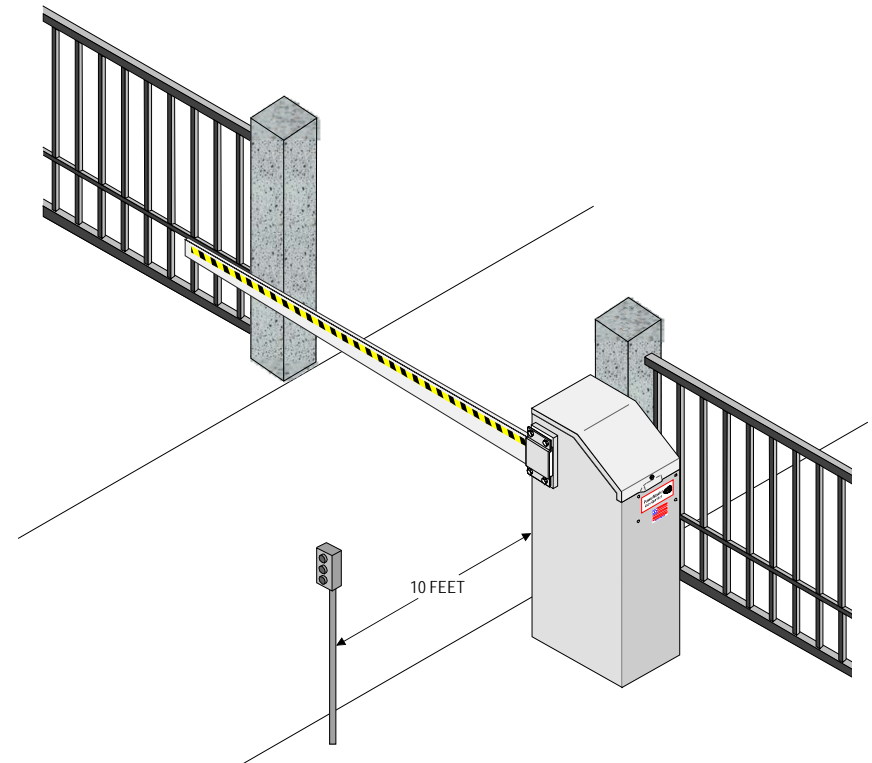

AFTER INSTALLATION

- ▲ You are responsible for ensuring that the end user understands the basic operations and safety systems of the unit, including the proper way to disengage and manually operate this unit.
- ▲ Point out that the safety instructions in this brochure are the responsibility of the end user, and then **LEAVE THIS BROCHURE WITH THE END USER**

END-USER SAFETY WARNINGS

Be sure you've been fully instructed on the sequence of operation for your specific gate system(s). Keep the gate properly maintained and have a qualified service person make repairs.

- ▲ 1. Be sure the following safety instructions are distributed to all persons authorized to use your gate.
- ▲ 2. **KEEP GATEWAY CLEAR AT ALL TIMES.** Your automatic gate is not for pedestrian use. No one should ever cross the path of the moving gate.

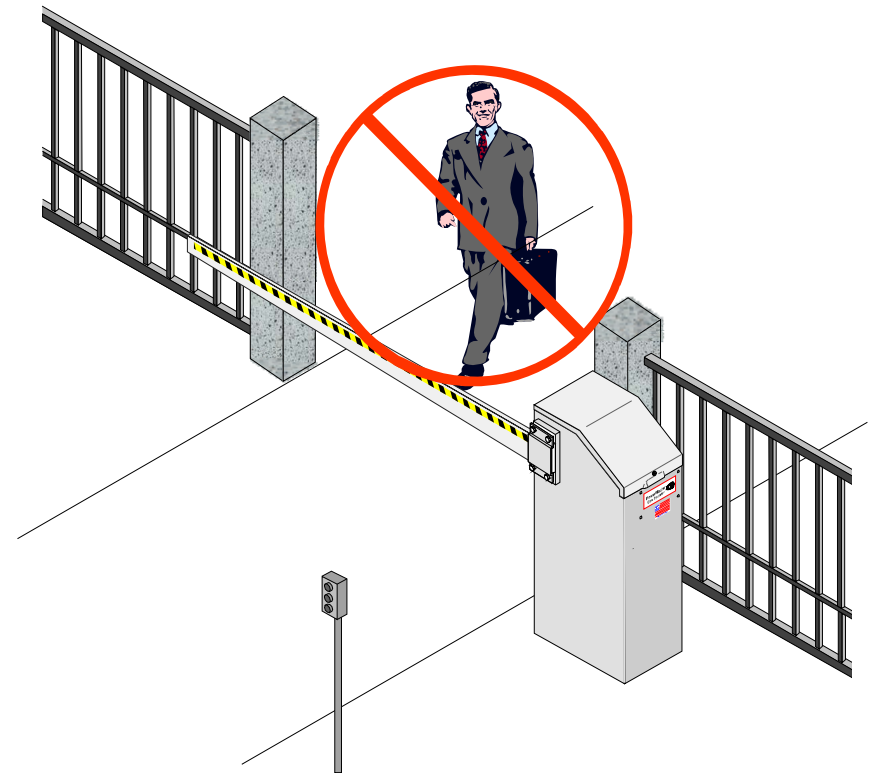

- ▲ 3. **DO NOT** allow children to play near your gate, or to operate the gate.

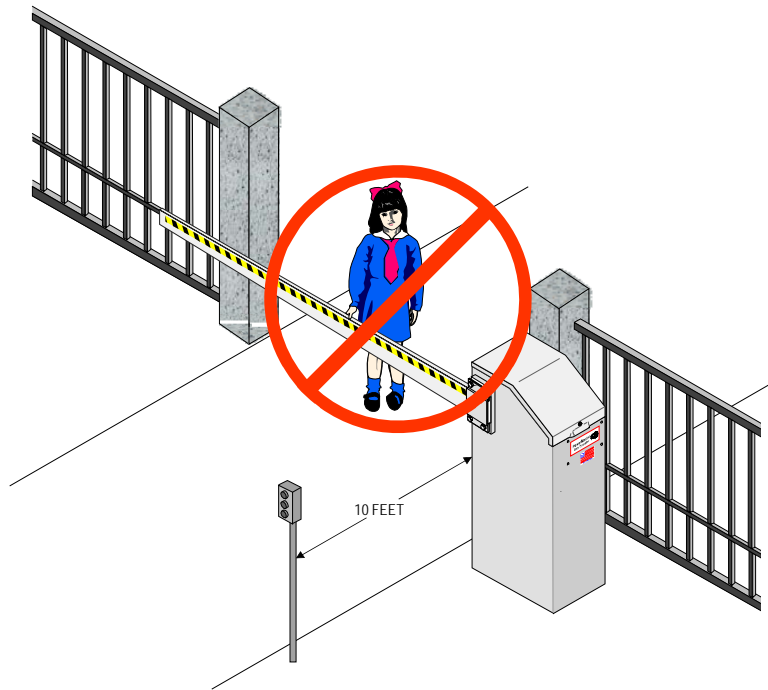

- ▲ 4. **DO NOT** operate your gate system unless you can see it when the gate moves.
- ▲ 5. Be sure a pushbutton or key switch has been installed for manual electric operation in the event your radio or card does not work. Any mounted control station should be located a minimum of 10 feet from the gate so the gate cannot be touched. Any pushbutton located in a building should be installed within sight of the gate.
- ▲ 6. **DO NOT** operate any controls without watching the movement of the gate.

- ▲ 7. Be sure the gate arm DOES NOT come within 2 feet of any rigid object, therefore causing an entrapment situation.

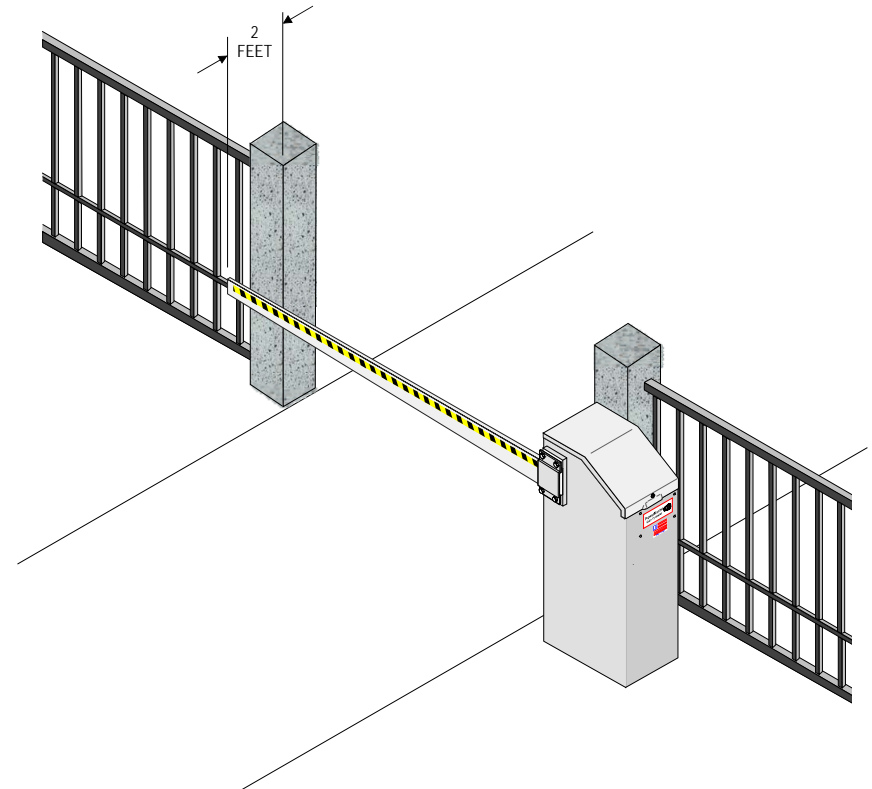

- ▲ 8. If your gate closes automatically, loop detectors should be installed to detect the presence of a vehicle.
- ▲ 9. If a contact or non-contact safety system has been installed check for proper operation at least once per month. **If these functions are observed to operate improperly, discontinue use and have it serviced immediately!**
- ▲ 10. To ensure safe operation of this equipment, you must read this safety manual and keep it for reference.

INSTALLATION INSTRUCTIONS

WARNING: DO NOT APPLY POWER UNTIL TOLD TO DO SO! RISK OF ELECTRICAL SHOCK OR INJURY MAY RESULT!

BEFORE INSTALLING OPERATOR

IMPORTANT:

1. Operator should always be mounted inside the gate.
2. All controls are to be mounted at least 10' from the gate arm.

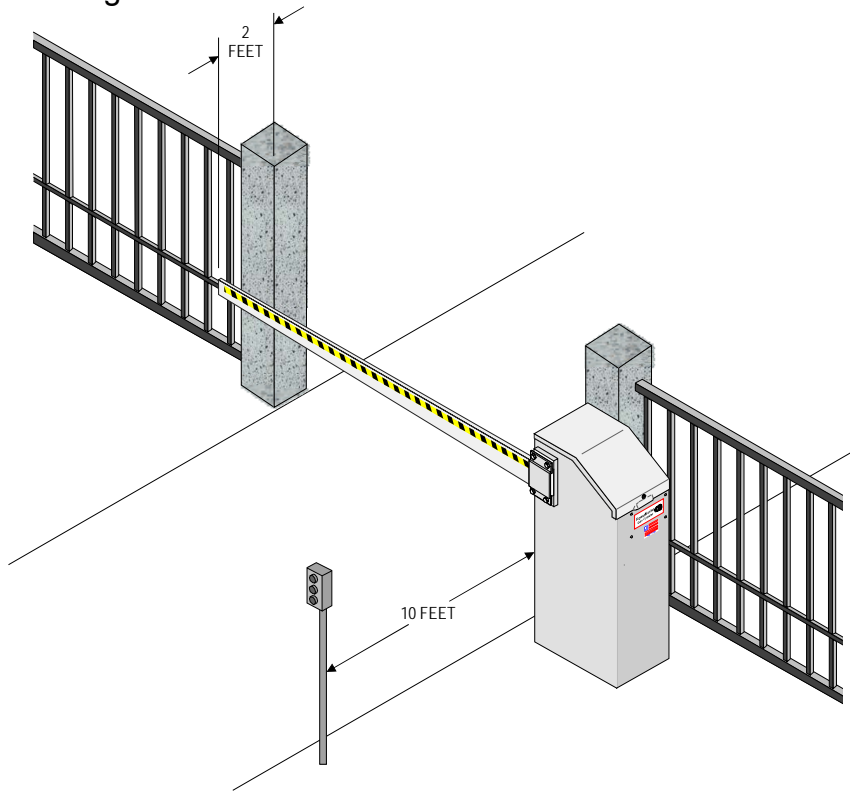

3. Allow at least 2 feet clearance from rigid objects to gate arm.

INSTALLATION OF CEMENT PAD

1. Install a mounting pad as shown below.

WARNING – Install operator mounting pad so moving arm will always be at least 2 feet from any fixed object.

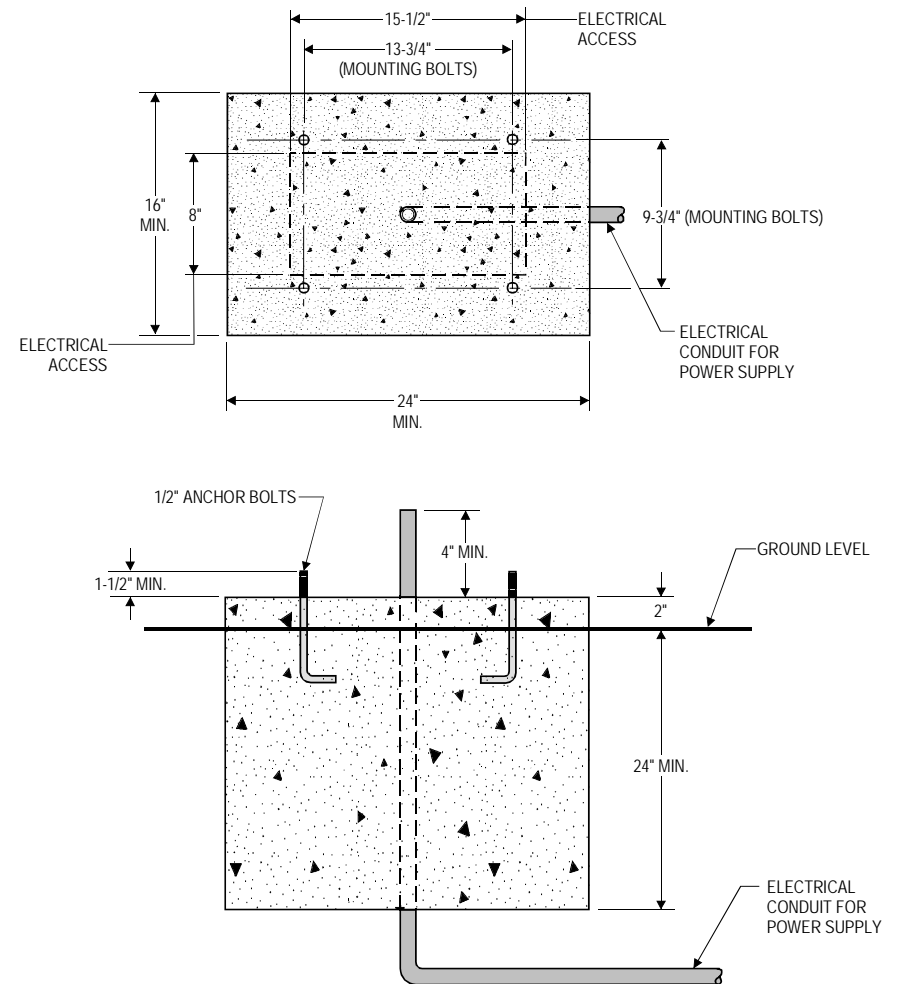

Note: Let cement cure for two days before proceeding.

INSTALLATION OF OPERATOR

1. Remove top cover as follows:
 - Insert key provided and unlock top cover
 - lift cover from lock side and slide forward
 - lift off cover
2. Remove side door of operator by reaching inside operator and unscrewing retaining knob at top of door. After removing retaining knob, push out top of door and lift away from operator. See diagram below.

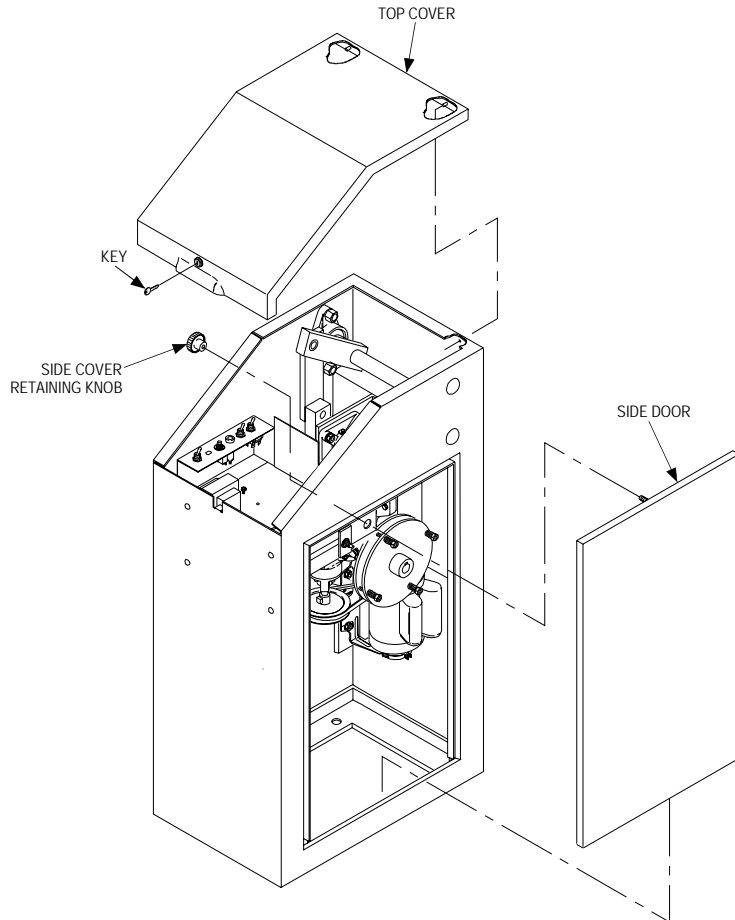

3. Mount operator on pad so that mounting bolts locate in operator base frame mounting holes and operator is parallel to fence line. (See diagram below.)
4. Secure operator to cement using 1/2" flat washers, lock washers and hex nuts as shown in diagram.

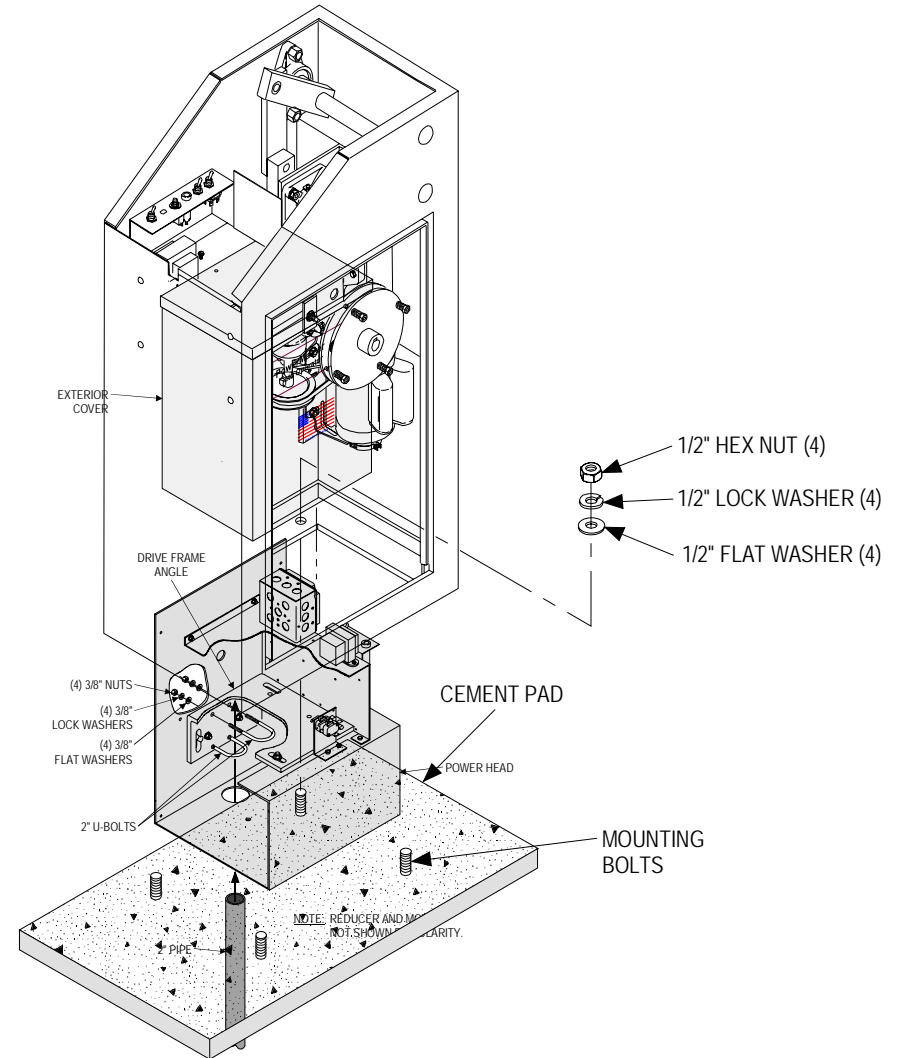

INSTALLATION OF BARRIER ARM

For 8', 10', or 12' Arms

1. Install arm cap using (4) 1/2" x 1-1/2" long hex bolts, lock washers and nuts as shown below. Do not tighten until told to do so.
2. Insert large end of wood arm into arm cap until flush with opposite edge of arm mounting flange.
3. Adjust arm to the desired horizontal position and secure by tightening the 1/2" mounting hardware.

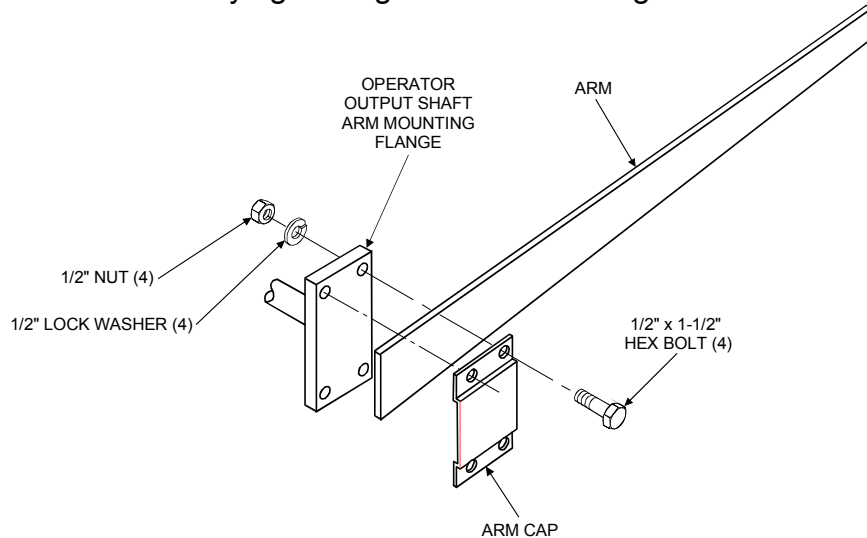

For 14', and 16' Arms

1. Install weight carrier bracket using (4) 1/2" x 1-1/2" long hex bolts, lock washers and nuts as shown below. Do not tighten until told to do so.
2. Insert large end of wood arm into weight carrier bracket until it hits stop.
3. Adjust arm to the desired horizontal position and secure by tightening the 1/2" mounting hardware.

4. Mount counter weight on weight carrier bracket using (2) 1/2" x 4" long hex bolts, lock washers and nuts as shown in diagram. Be sure to use holes in weight carrier bracket as shown in diagram for proper arm balance.

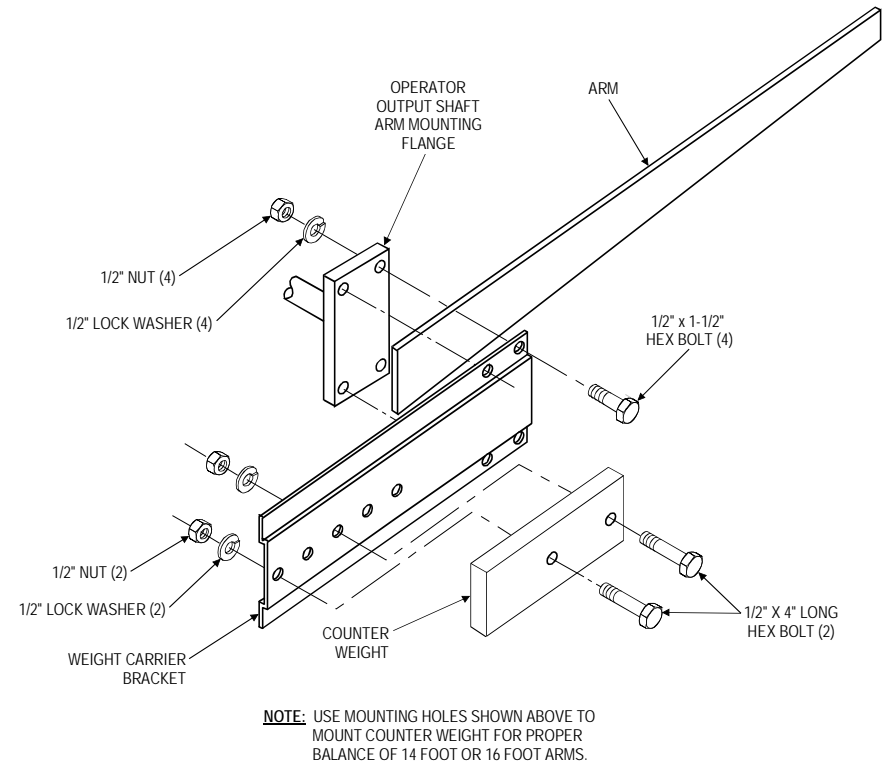

Electrical Connections

WARNING- DO NOT APPLY POWER UNTIL TOLD TO DO SO. RISK OF SHOCK OR INJURY MAY RESULT!

NOTE: Wiring to operator must use watertight materials in accordance with local electric code. See wire gauge/distance charts for proper sizing. Master/Slave installations should have **SEPARATE** power supply wiring or length of wire runs should be figured at half that shown on the chart. **This unit must be grounded in accordance with N.E.C. and local codes.**

Before connecting the operator, use a voltmeter to determine that the electrical service is 115V. THIS OPERATOR CANNOT BE CONNECTED TO 230 VOLTS. Damage will result which is not covered under warranty.

Line Voltage	HP	14 AWG	12 AWG	10 AWG	8 AWG	6 AWG
115 VAC	1/2	150'	250'	400'	500'	650'

1. Be sure power switches at source and in operator are OFF.
2. Connect incoming power lines and ground wire as shown below.

Hot leg (black) to BLACK; Neutral (white) to White; Ground to GREEN

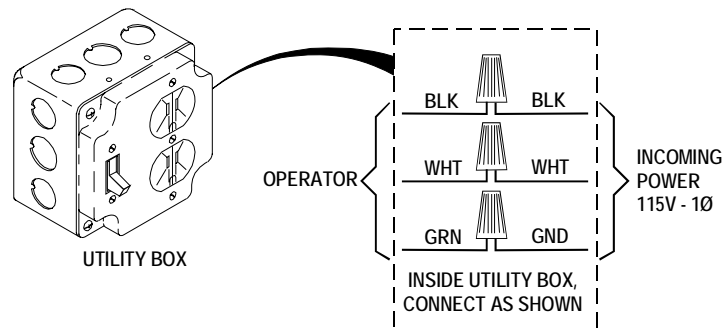

LOW VOLTAGE WIRE GAUGE/DISTANCE CHART	
24 AWG:	Up to 150'
20 AWG:	150' - 200'
18 AWG:	250' - 1,500'

Control wiring should be run as twisted pairs. **DO NOT** run control wires in the same conduit as power wires, telephone wires, or loop detector leads.

CLUTCH ADJUSTMENT

Note: The clutch is set to the lightest setting at the factory and will require adjustment for proper operation.

1. Remove top cover and side door.

Note: Before starting clutch adjustment, turn off power switch on electrical panel, and set all four adjusting nuts on clutch to the same position.

2. To tighten clutch, turn the four adjustment nuts, as shown below, 1/4 turn at a time, in a clockwise direction.

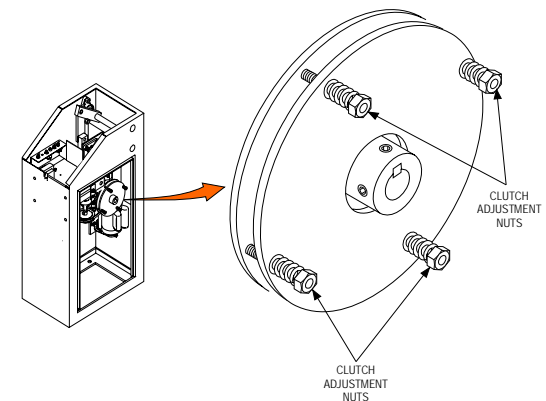

3. Replace side door to activate power interlock.
4. Turn on power switch on electrical panel.
5. Test barrier gate operation using the OPEN/CLOSE control switch located on the electrical panel.

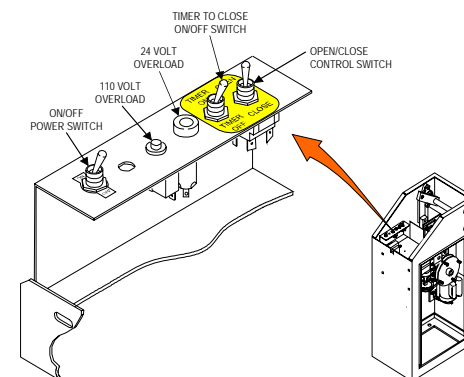

- Observe clutch during the start of the OPEN cycle to determine if clutch is slipping.
- Repeat adjustment procedure, step #1 - #4 until there is no clutch slippage when operator starts the OPEN cycle.

MANUAL OPERATION

- Remove top cover, and side door.

▲ **WARNING: TO AVOID INJURY, TURN OFF POWER SUPPLY SWITCH TO OPERATOR BEFORE MAKING ANY ADJUSTMENTS.**

- Loosen adjustment nuts on drive clutch. Turn clutch to raise or lower gate arm.
- To return to powered operation re-adjust clutch as shown in clutch adjustment section.
- Turn on supply power to operator. Replace side door and top cover.

LIMIT ADJUSTMENT PROCEDURE

WARNING: TURN OFF POWER SUPPLY BEFORE MAKING ANY ADJUSTMENTS.

NOTE: The drive linkage geometry prevents more than a 90 Degree gate arm movement. (Horizontal to Vertical position.)

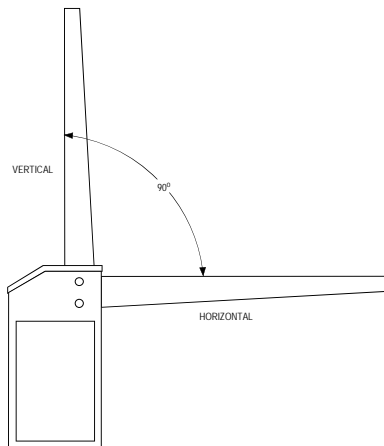

- In order to achieve 90 degree arm movement from the drive linkage, the limit cams must be set to obtain the linkage positions shown below.

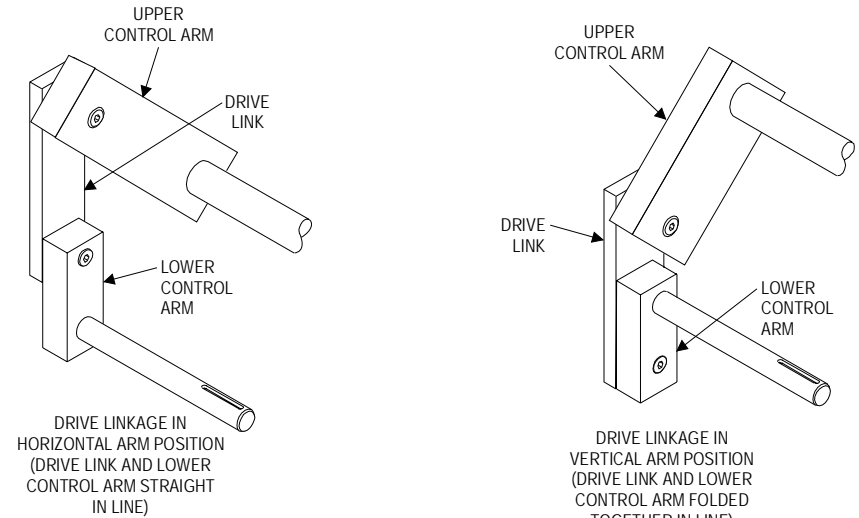

- To set limit cam, loosen set screw and rotate to desired position then tighten set screw.

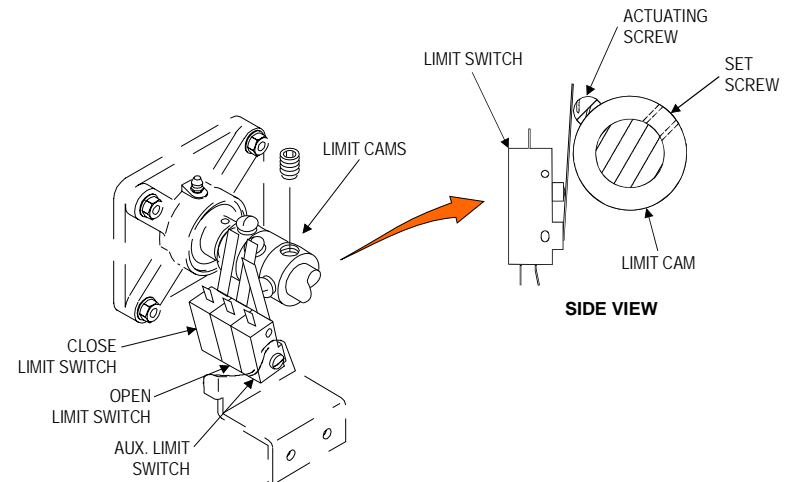

Note: Limits are set for 90 degree arm movement at factory.

- If a shorter stroke than 90 degrees is desired at either end, limits may be reset to achieve this.
- If the limit cams are adjusted correctly and the operator is maintaining 90 degree rotation but the arm is not horizontal in the down position; loosen the (4) mounting bolts, adjust arm and retighten mounting bolts.

CONNECTION OF A 2 BUTTON STATION

NOTE: All Control contacts must be **NORMALLY OPEN**.

- Connect "COMMON" to Terminal #5.
- Connect "OPEN" button to Terminal #6.
- Connect "CLOSE" button to Terminal #7.

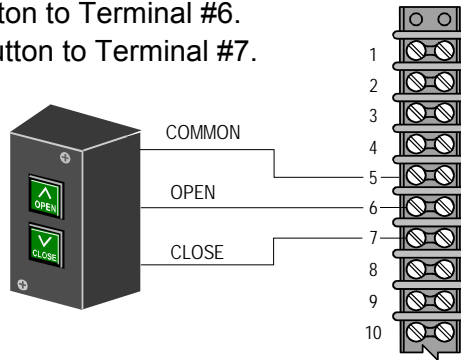

CONNECTION OF A 1 BUTTON STATION

NOTE: Control contacts must be **NORMALLY OPEN**.

- Connect one wire from the single button control to terminal #1 on the operator terminal strip.
- Connect the second wire from the single button control to terminal #2 on the operator terminal strip.

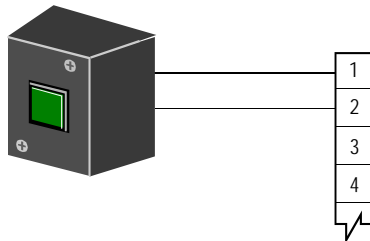

RADIO CONTROL INSTALLATION

- Mount radio receiver in cabinet of operator. A mounting bracket has been provided which may be used to directly attach many commonly used radio receivers as shown below.

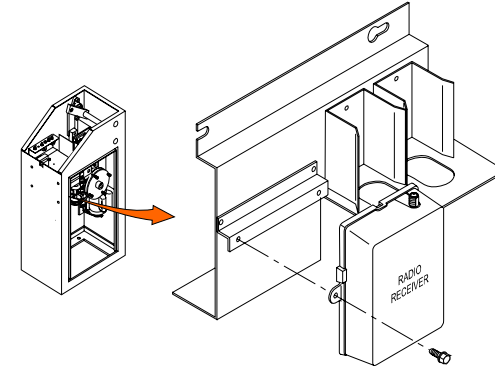

NOTE: For radios supplied with a coax cable and antenna, longer radio range may be obtained by drilling a 3/8" diameter hole through the operator cabinet and mounting antenna outside the operator.

A Three or Four wire radio control receiver can be installed on this operator. See the diagrams below for the correct connections to match your installations equipment and desired functions.

NOTE: If your radio's connecting wires are not color coded as shown, see the radio's installation manual to determine which wires are for the normally open contacts and which require the 24 VAC Power Supply.

4 WIRE RADIO CONNECTION

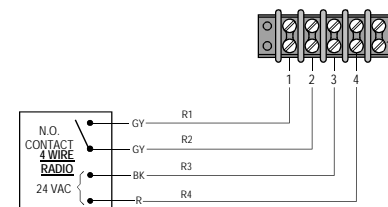

3 WIRE RADIO CONNECTION

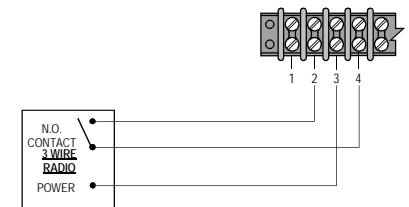

TIMER TO CLOSE OPTION

The operator is equipped with a timer to close option for use with other control devices such as a radio control, or card key control.

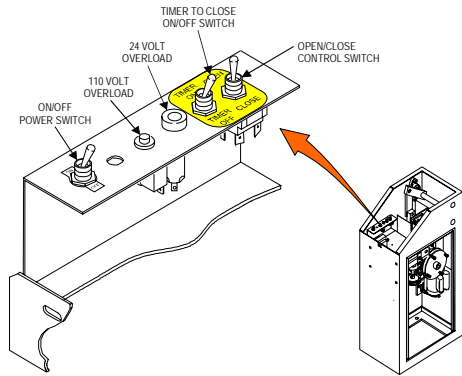

The **AUTO RECLOSE TIMER** adjustment screw is located on the printed circuit board. The operator is shipped from the factory with this timer preset to the "MIN." position; fully counter clockwise, and the "TIMER TO CLOSE" toggle switch in the "OFF" position. As the timer adjustment screw is rotated clockwise, the closing of the gate can be delayed from 1 second to 10 seconds.

1. To activate the AUTO-RECLOSE TIMER, put the "TIMER TO CLOSE" toggle switch located on the electrical control panel, to the "ON" position.
2. The desired length of time before closing may be selected by turning the timer adjustment on the printed circuit board as shown below. A timing option between 0 – 10 seconds is available.

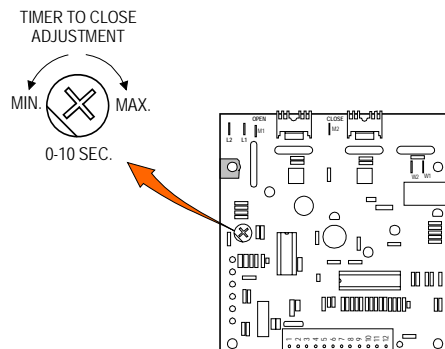

EXTERNAL TIMER DEFEAT SWITCH CONNECTION

1. Connect the two wires from the normally open terminal of the external "Timer Defeat Switch" to terminals #9 and #10 as shown in diagram.

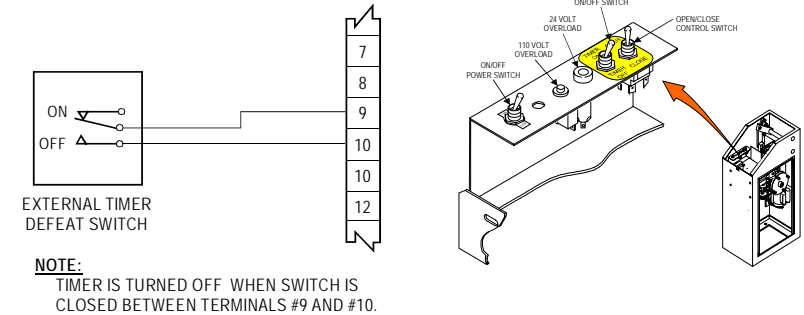

2. Move the "Timer To Close" switch on the operator control panel to the "ON" position.

AUXILIARY LIMIT SWITCH

There is an auxiliary limit switch available which provides a normally open and normally closed set of contacts for use with additional equipment. It can be connected through terminals #12, #13, and #14 on the terminal strip as shown in the diagram, and can be set to activate at any point during gate travel. Adjustment is accomplished by rotating the Aux. Limit cam to the desired position and securing that location with the set screw in the cam.

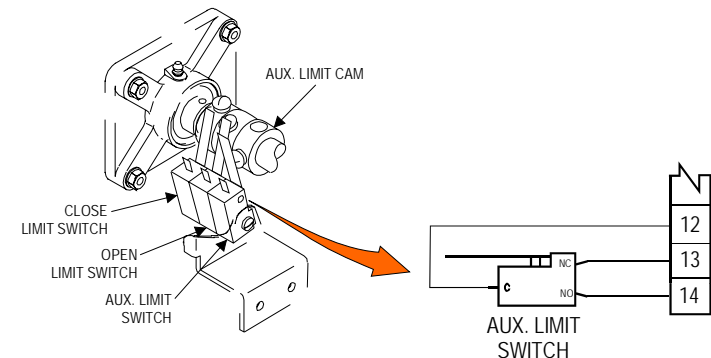

NOTE: This option is not available when a MASTER/SLAVE installation is connected to a radio control.

MASTER - SLAVE OPERATION

CONNECTIONS FOR MASTER/SLAVE OPERATION

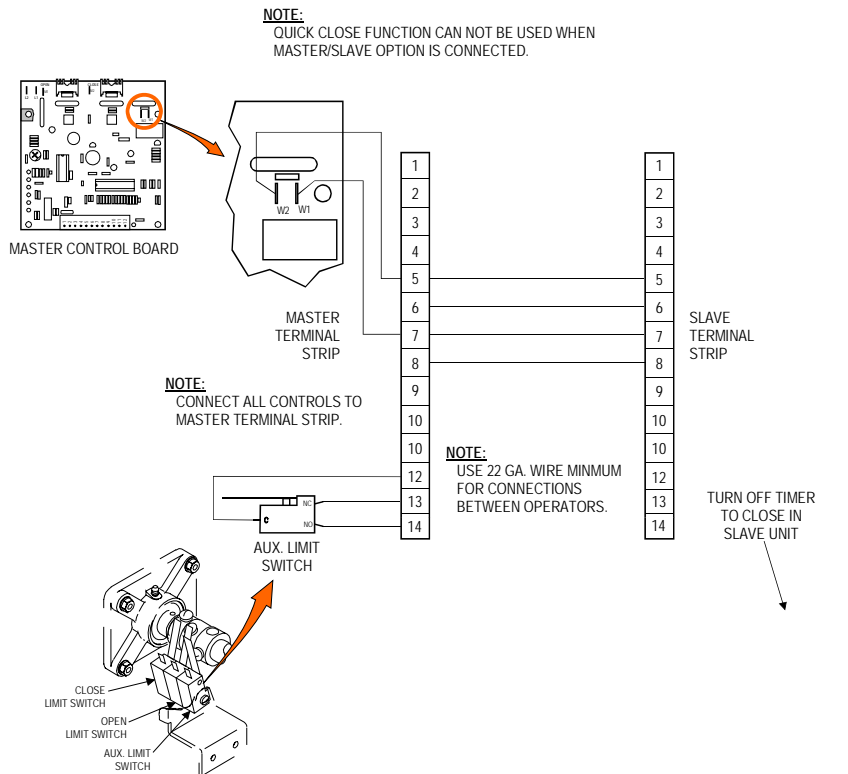

1. Connect terminal #5 on Master terminal strip to terminal "W1" on Master Control Board.
2. Connect terminal "W2" on Master Control Board to terminal #7 on Slave terminal strip.
3. Connect terminal #5 on Master terminal strip to terminal #5 on Slave terminal strip.
4. Connect terminal #6 on master terminal strip to terminal #6 on Slave terminal strip.
5. Connect terminal #8 on Master terminal strip to terminal #8 on Slave terminal strip.
6. Turn off "Timer To Close" switch on Slave control panel.

CONNECTION FOR A 1 BUTTON STATION W/ MASTER-SLAVE OPTION

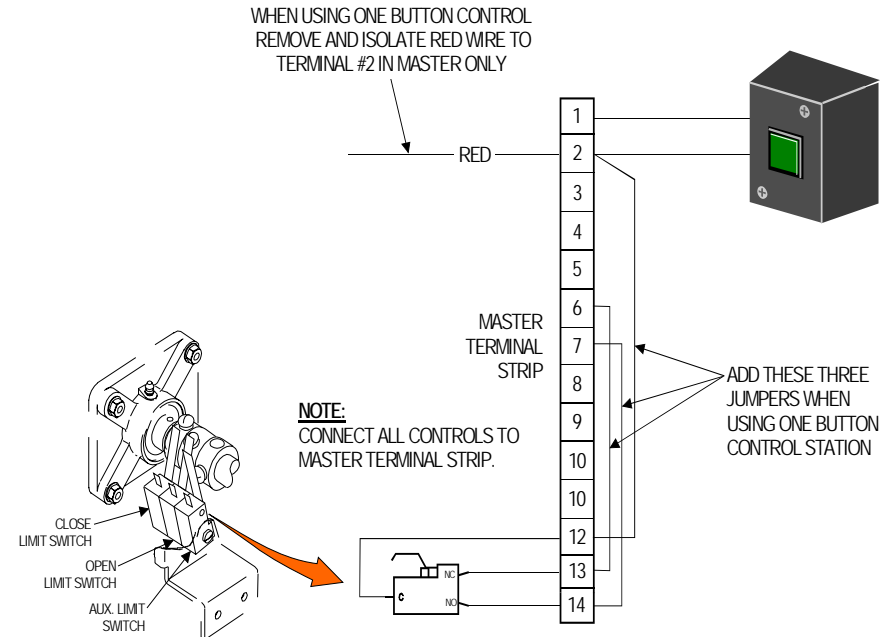

1. Remove red wire from terminal #2 on Master terminal strip.
2. Connect 1-Button Control to Master terminal strip terminals #1 & #2 as shown in diagram.
3. Insert a jumper between terminal #2 and terminal #12 on Master terminal strip.
4. Insert a jumper between terminal #6 and terminal #13 on Master terminal strip.
5. Insert a jumper between terminal #7 and terminal #14 on Master terminal strip.
6. Adjust the auxiliary limit switch cam so the "Aux. Limit" switch activates just before the "OPEN" limit switch.

NOTE: This adjustment is preset at the factory and should not need adjustment unless disturbed.

CONNECTION FOR RADIO CONTROL W/ MASTER-SLAVE OPTION

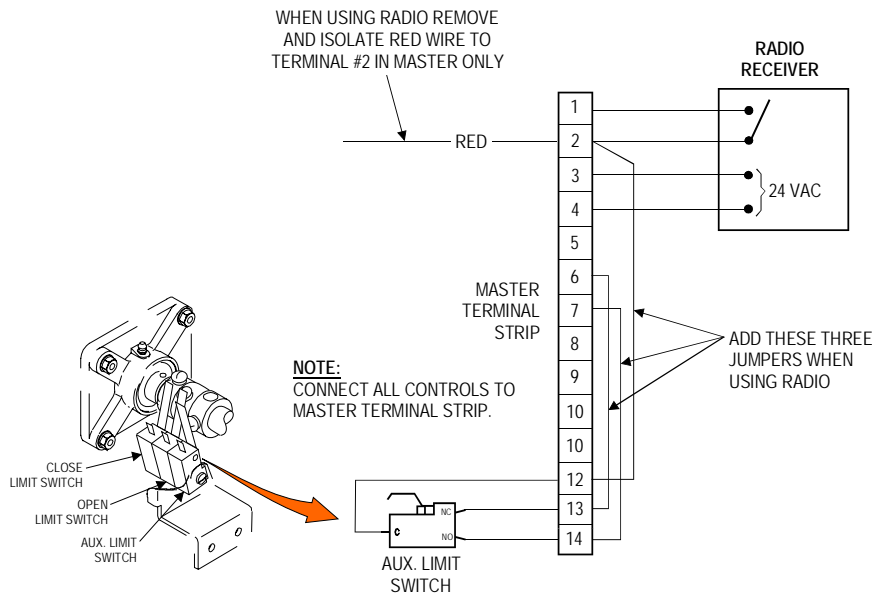

1. Remove red wire from terminal #2 on Master terminal strip.
2. Connect radio to Master terminal strip as shown in diagram: Open contacts from radio to terminals #1 and #2, 24VAC power to radio from terminals #3 & #4.
3. Insert a jumper between terminal #2 and terminal #12 on Master terminal strip.
4. Insert a jumper between terminal #6 and terminal #13 on Master terminal strip.
5. Insert a jumper between terminal #7 and terminal #14 on Master terminal strip.
6. Adjust the auxiliary limit switch cam so the "Aux" limit switch activates just before the "OPEN" limit switch. This adjustment is preset at the factory but may need a minor adjustment for certain radios.

INSTALLATION OF EDGE SENSOR OR PHOTOEYES

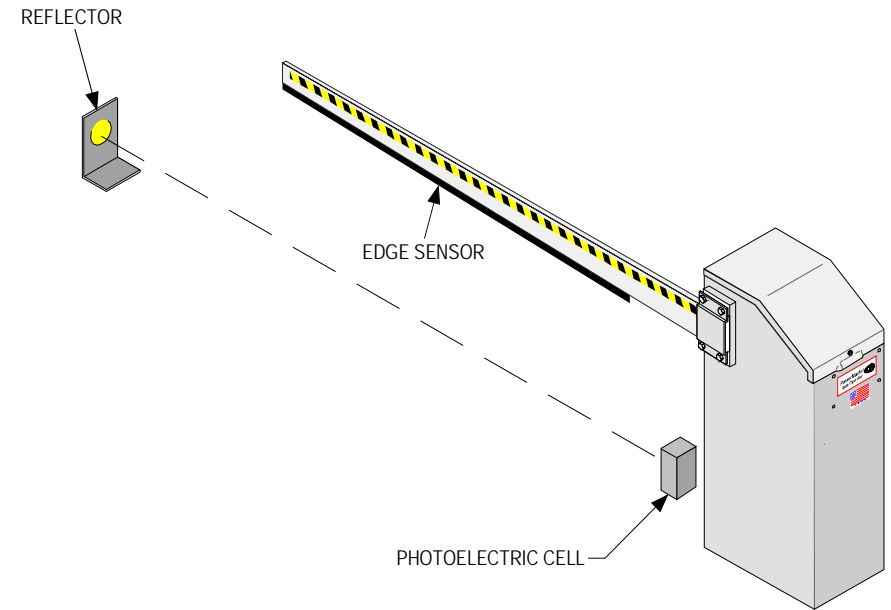

NOTE: 24 VAC power is available between terminals 3 & 4 for devices such as photo eyes, wireless edges, etc. **All safety device contacts must be NORMALLY OPEN.**

1. Install edge sensor or photoelectric eye system as shown. Photocells should be installed at least 10" above the ground.
 - ▲ **NOTE:** All hard wiring to safety edges must be installed so there is no threat of mechanical damage to wiring between components, when the gate is moving.
 - ▲ **NOTE:** A separate pedestrian gate must be installed if there is no other entry access but the vehicular gate.
2. Electrically connect sensing system to operator terminal strip as shown below.

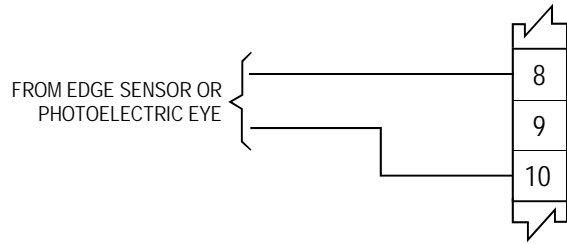

usually used for one way traffic. It can only be activated when there is no input from an “Open” or “Close Safety” device . Once activated it will disable any “Close Safety” device and can only be overridden by an “Open” input. Therefore, this option should only be used in secure applications and a close warning device should be connected.

LOOP DETECTOR SYSTEMS AND INSTALLATION

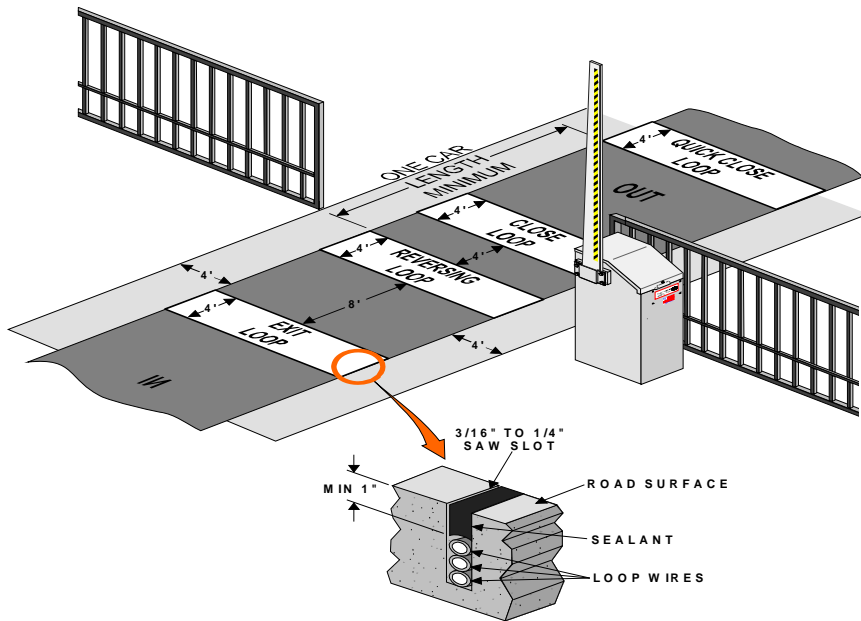

1. The **EXIT LOOP** provides a signal to open the gate when a vehicle enters the loop zone.
2. The **REVERSING LOOP** protects a vehicle in the loop zone from being contacted with the gate by overriding any close signal while the gate is open, and by reversing the gate if closing, unless the “Quick Close” Anti-Tailgate loop has been installed.
3. The **CLOSE LOOP** provides a signal to close the gate when a vehicle exits the loop.
4. The **QUICK CLOSE LOOP** (Anti-Tailgate feature) is

LOOP INSTALLATION

STANDARD LOOP LAYOUTS
For 36" High Detection

1. Layout the desired loop locations per the diagram. The standard size chart at right will give an approximate length of wire required for various loop dimensions and number of turns required.

CAUTION: The Loop wires and Lead-in wires must be a continuous piece of wire without splices. The chart at right shows the amount of wire required for the loop sizes shown. The length of the lead-in should be added to the loop wire length to get the required amount of wire for the application. Only use wire intended for this type of application. (Type XHHW insulation 16AWG)

LOOP SIZE	# TURNS	LOOP WIRE LENGTH (FT)
4' X 4'	4	64'
4' X 6'	4	80'
4' X 8'	3	72'
4' X 10'	3	84'
4' X 12'	3	96'
4' X 14'	3	108'
4' X 16'	3	120'
4' X 18'	3	132'
4' X 20'	3	144'
4' X 22'	3	156'
4' X 24'	3	168'
4' X 26'	3	180'
4' X 28'	3	192'
4' X 30'	2	136'
4' X 32'	2	144'
4' X 34'	2	152'
4' X 36'	2	160'
4' X 38'	2	168'
4' X 40'	2	176'

NOTE: Buried steel from drains or other systems may affect functioning of the loop system. Check with the factory for advice on any special installations. (1-800-243-4476).

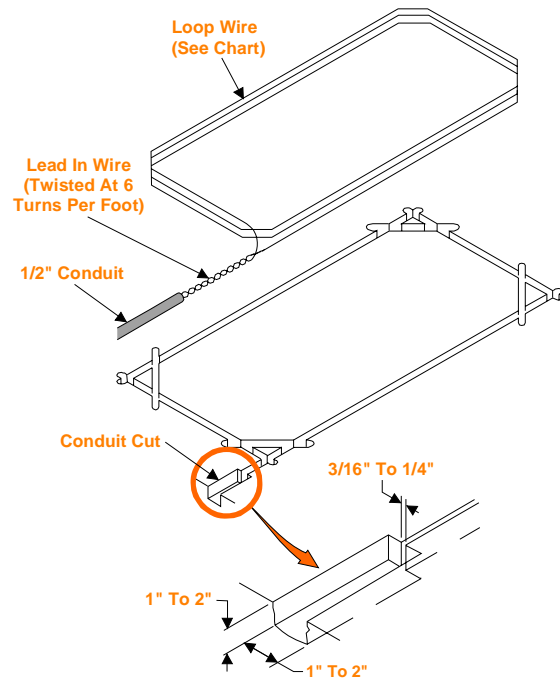

2. Cut the required groove as shown in the diagram above at the locations laid out in **Step #1**.

3. Leave enough wire for the LEAD IN, and insert the specified number of turns of wire into the cut grooves. (See chart on previous page.)

CAUTION: Be careful not to damage the wire insulation during installation.

4. After completing the required number of loop turns, twist the ends together at the rate of 6 turns per foot to form the **LEAD-IN**.

5. Seal the **LEAD-IN** wire in the conduit to prevent moisture seepage into the conduit.

6. Fill over the loop wires in the groove with a recommended loop sealant. Contact your distributor for available sealants.

7. An accessory mounting bracket has been provided in the operator for mounting two loop detectors. (See diagram)

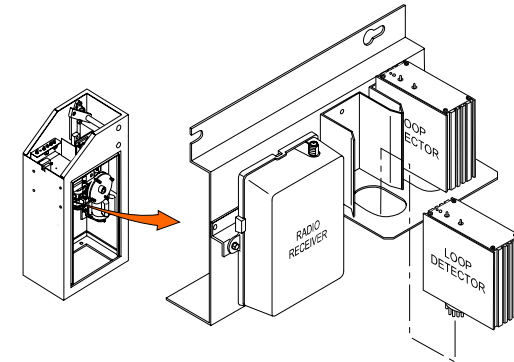

8. Connect loop detector to the control board and the wire loop as shown in the following diagrams.

Note: The following diagrams show single loop connections. For multiple loop connections consult the loop detector's instruction manual, or call the PowerMaster Technical line at 1-800-243-4476.

1. The **EXIT LOOP** provides a signal to open the gate when a vehicle enters the loop zone.

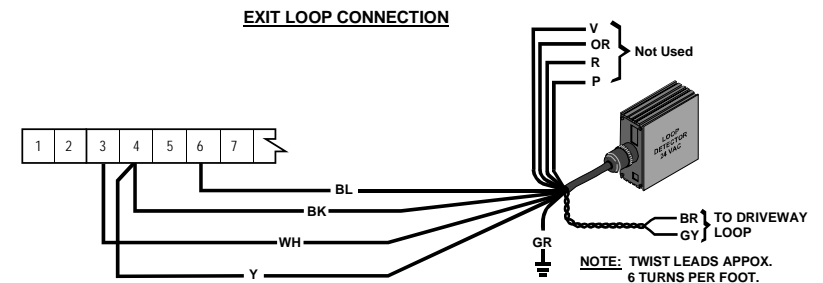

2. The **REVERSING LOOP** protects a vehicle in the loop zone from being contacted with the gate by over riding any close signal while the gate is open, and by reversing the gate if closing.

REVERSING LOOP CONNECTION

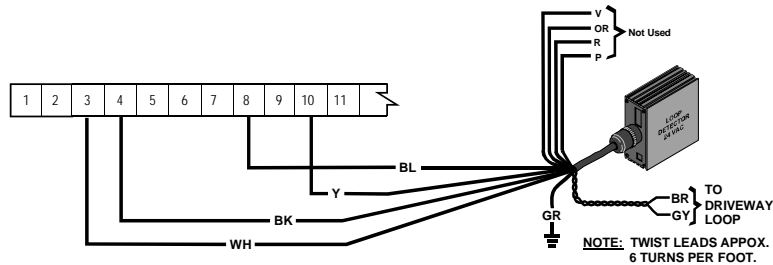

QUICK CLOSE LOOP CONNECTION

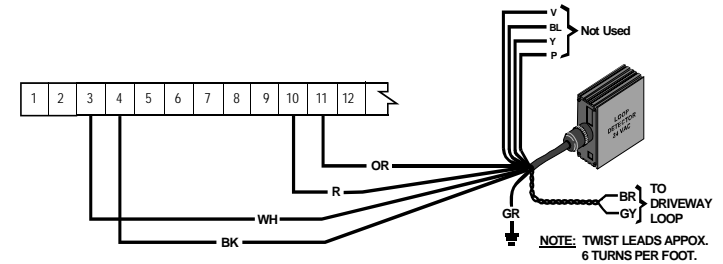

3. The **CLOSE LOOP** provides a signal to close the gate when a vehicle exits the loop.

CLOSE LOOP CONNECTION

▲ **WARNING** LOOP DETECTOR MUST BE PROGRAMMED TO ACTIVATE OPERATOR WHEN VEHICLE LEAVES LOOP. (SEE LOOP DETECTOR INSTRUCTIONS OR CALL FACTORY TECHNICAL HELP AT 1-800-243-4476)

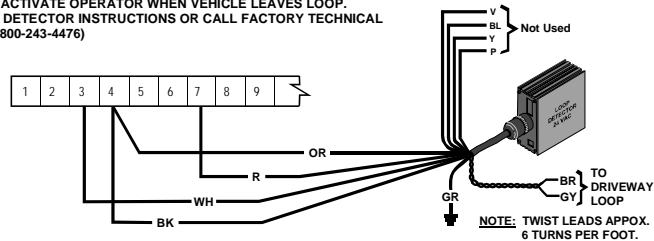

CLOSE WARNING CONNECTION

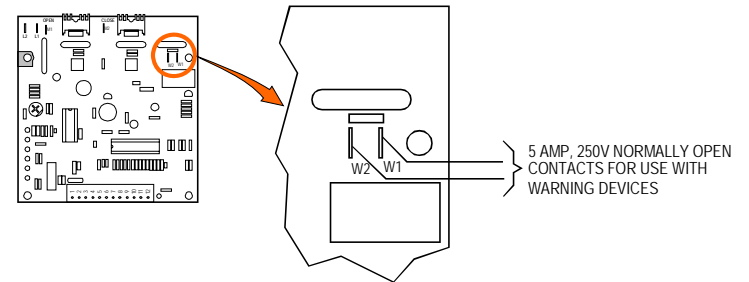

4. The **QUICK CLOSE LOOP** (Anti-Tailgate feature) is usually used for one way traffic. It can only be activated when there is no input from an “Open” or “Close Safety” device. Once activated it will disable any “Close Safety” device and can only be over ridden by an “Open” input. Therefore, this option should only be used in secure applications and a close warning device should be connected to terminals W1 and W2. (See “Close Warning Connection Diagram”)

R&S Automation
7200 E. 92nd Avenue
Unit A
Portland, OR 97266
877-388-4001
503-771-4685
Fax 503-774-6708

John Greene Corp.
2807 Center Circle Drive
Downers Grove, IL 60515
800-374-7890
Fax 630-627-7995

R & S Automation Inc.
15075 Wicks Blvd
San Leandro, CA 94577
800-543-6001
510-357-4110
Fax 510-483-1326

R & S Automation Inc.
1560 N. Missile Way
Anaheim, CA 92801
800-963-3111
714-449-1645
Fax 714-449-1679

John Greene Corp.
3024 Avenue E. East
Arlington, Tx 76011
800-925-7890
Fax 817-633-5735

John Greene Corp.
3516 E. Norvell Bryant Hwy.
Hernando, FL 34442
800-323-3674
Fax 352-726-8998

Power Door Products
610 Fenimore Rd.
Mamaroneck, NY 10543
914-698-5083
Fax 914-698-6866

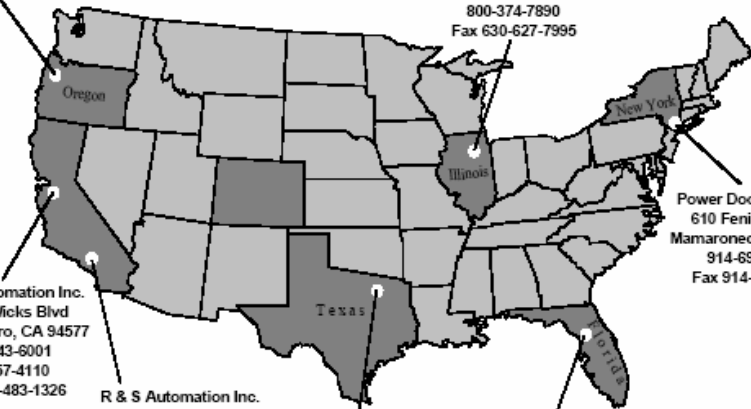

Toll Free technical support @ 1-800-243-4476
Email to techsupport@power-master.net



Call 1- 800 - 323 - 3674
to order or to find a distributor near you

Warehouses across the country w/
factory trained managers

Prompt delivery from stock

Special operators normally ship
within 7 days

06-0926 SBG