

**INSTALLATION INSTRUCTIONS
FOR THE
"S" AND "V" MODEL
OVATION SYSTEMS**

IMPORTANT NOTICE

Make sure you know the local telephone tariff arrangements before installing this system. In some areas, the telephone company assumes responsibility for the phone lines up to each resident's apartment. In that case, either the telephone company will assume responsibility for the installation of the RJ71C jack to the telephone lines (as is normally the case), an additional pair of wires will have to be run to and from each apartment, or the building owner will have to assume responsibility for the phone lines between the Ovation and their apartments.

- The Ovation system contains static sensitive parts. To avoid damage to the static sensitive parts, ground the system and yourself while handling the board(s).
- Do not disconnect or reconnect anything from the system while the power is connected to any element of the system.
- Always use these instructions when you are installing the system or making changes to the system configuration.

TABLE OF CONTENTS

BASIC INSTALLATION RULES	3
PART 1 SYSTEM OVERVIEW	4
1. OVATION CONTROLLER	4
2. LINE INTERFACE BOARDS (LIBs)	4
PART 2 SAMPLE INSTALLATION.....	6
1. SINGLE ENTRANCE	6
2. MULTIPLE ENTRANCES	7
PART 4 PHONE LINE INSTALLATION.....	8
1. ARRANGING TELEPHONE INSTALLATION	8
2. INSTALLING RJ71C JACKS.....	8
3. LIB PLANNING FORM.....	9
PART 5 PULLING CABLES	10
1. SINGLE ENTRANCE	10
2. MULTIPLE ENTRANCES	12
PART 6 MOUNTING THE CABINETS.....	14
1. OVATION "S" AND "V" MODEL CABINETS.....	14
2. LINE INTERFACE BOARD (LIB) HOUSINGS	15
PART 7 SETTING LIB ADDRESSES	16
1. SINGLE DECADE LIB SWITCH	16
2. THREE DECADE LIB SWITCH	17
PART 8 MAKING BASIC CONNECTIONS.....	18
1. OVATION CONTROLLER CONNECTIONS.....	18
2. LIB CONNECTIONS	20
PART 9 INSTALLING ADDITIONAL FEATURES	23
1. POSTAL LOCK	23
2. AUX OPEN/REQUEST FOR ACCESS.....	23
3. DOOR POSITION SENSING	23
PART 10 TESTING AND ADJUSTING THE UNIT	24
1. VERIFYING CODE CAPABILITIES	24
2. ADJUSTING SIDETONE BALANCE.....	24
3. VERIFYING TELEPHONE AND DOOR/GATE CONNECTIONS	24
4. AUDIO ADJUSTMENT.....	25
PART 11 GLOSSARY OF DIAGNOSTIC INDICATORS	26

1. OVATION CONTROLLER BOARD.....	26
2. LINE INTERFACE BOARD (LIB)	26
FCC REQUIREMENTS	27
1. INSTALLATION.....	27
2. TYPE OF SERVICE	27
3. TELEPHONE COMPANY PROCEDURES.....	27
4. IFF PROBLEMS ARISE	27
5. RADIO FREQUENCY	27
DOC REQUIREMENTS	28

IMPORTANT NOTICE

The Sentex Systems warranty on this system is conditioned upon Sentex Systems being paid in full for this equipment. This warranty will not be honored until such payment is received by Sentex Systems.

In the interest of better serving its customers, Sentex is constantly in the process of upgrading its products. Consequently, Sentex reserves the right to make changes in the products described in this manual without notice and without obligation of Sentex to notify any persons of any such revisions or changes. Additionally, Sentex make no representations of warranties with respect to this manual.

This document is protected by copyright, and may not be copied or adapted without the prior written consent of Sentex Systems. This document contains information proprietary to Sentex and such information may not be distributed without the prior written consent of Sentex. The firmware included in the Sentex Ovation system as they relate to this documentation is also protected by copyright and contain information proprietary to Sentex.

Copyright © 2000
All Rights Reserved

Sentex Systems
Chatsworth, CA

Visit us at www.sentexsystems.com

BASIC INSTALLATION RULES

PLEASE READ THIS SECTION VERY CAREFULLY BEFORE BEGINNING YOUR INSTALLATION.

In the sections that follow, detailed procedures are discussed for each step required to install the Ovation system. In addition to these specific procedures, there are general rules which will help ensure that your installation is done correctly and efficiently:

1. **GROUND THE SYSTEM.** The Ovation system contains parts which may be damaged by static discharge. This type of damage is not covered by Sentex's warranty. A proper earth ground connected to the controller and LIB housings at the grounding points shown in Figures 12 and 14 will significantly reduce the chances of damage or improper operation. The shields in the cables specified for all remote sensors and controls should also be connected to earth ground at the point shown in Figure 12.

To be effective, the ground connection must be made by running 12 AWG copper wire to a good ground point (e.g., an electrical panel, a metallic cold water pipe that runs into the earth, or a grounding rod at least 10 feet in length that is driven into the earth) within 12 feet of the system. If you cannot meet these requirements, a ground will be of little value. Even if you have a good earth ground, you should still try to discharge any static electricity before handling the circuit boards.

2. **PROVIDE POWER FROM A DEDICATED SOURCE.** The outlet(s) into which you plug the transformers provided, or a DC power supply, should be wired to their own circuit breaker. This will reduce the line noise introduced into system power and minimize the risk of having other equipment interrupt system operation. Additionally, each Ovation controller, LIB housing, and door strike must have their own individual transformer.
3. **DO NOT OVERLOAD THE TERMINAL BLOCKS.** The terminal blocks used in the Ovation system are unpluggable and the pins are soldered into the boards. To connect your wires, remove the "head" from the correct terminals and open the screws. Insert the wire into the correct opening on the front and tighten the screw until the wire is held snugly. When you have made all connections for a given "head," plug it back onto the pins designated for that terminal block.

Stranded wire must be between 16 and 24 AWG. Solid wire must be between 18 and 24 AWG. This is the total thickness measurement, so if you are putting two wires in together, the combined thickness must fall within this range. **NEVER** try to insert more than two wires per terminal.

4. **ENSURE GOOD CONNECTIONS.** A light tug on the wire will tell you if the connection is secure. When reconnecting system components, make sure all pins are straight on chips, connectors, and terminal block heads.
5. **READ THE MARKINGS CAREFULLY.** The connection points are marked on the boards clearly. Before making any connection, be sure to read the marking and check it against the corresponding figure in these instructions so that you understand the connection you are making.
6. **TRAIN YOUR CUSTOMER.** The Ovation system is very simple to program and use once a short learning period has been completed. However, untrained programmers can cause serious problems for you and themselves. Ensure your customer has a copy of the manual Programming and Use Instructions for all Ovation Systems (Doc. No. 6001012) to guide them. **SPEND TIME NOW** to train your customer on proper use of the system. It will save you and them a lot of aggravation and inconvenience later.

PART 1

SYSTEM OVERVIEW

The Ovation telephone entry system connects directly to all of the resident phone lines in your building, allowing residents to be called without use of external telephone lines. As a result, the Ovation system does not generate telephone charges, either on a monthly or per call basis. The Ovation system is made up of two basic components:

1. OVATION CONTROLLER

This component controls switching of the resident's telephone lines, visitor communications and door access. The "S" series is the simplest system, with the same housing as the Spectrum. The "V" series has an integral, lighted directory, with the same housing as the Vista. Both are available in handset and hands free models, are mounted at the entrance of the building or complex, and contain a main processor board and, if used, a hands-free board.

- There is also a Lobby Phone feature which can be used in addition to the "S" and the "V" series of systems. This feature can be used in the handset or in the hands-free models.
- The controller for each of these systems is then connected to a chain of Line Interface Boards, each of which is connected to as many as twelve resident telephone lines.

2. LINE INTERFACE BOARDS (LIBS)

These components connect the resident's telephone to the Ovation Controller when a visitor wants to contact that resident. At all other times, the resident's telephone line is connected directly to the telephone company. The Line Interface Boards are contained in an LIB housing mounted inside the building, usually close to the telephone junction box.

The Ovation system is capable of carrying out the following functions, several of which are optional (your dealer knows which are included in your system):

- 1. Visitor entry:** When a visitor presses the # key and enters the resident's directory code on the controller keypad, that resident's line is selected and rung. The resident can talk with the visitor and allow entry at the main door or gate by dialing a 9, or at a second door or gate by dialling 5.
- 2. Call waiting:** If the resident's telephone is in use, two short tones will signal the visitor's call.
 - 3 If the resident dials a 2, the call in progress is put on hold and the telephone connects with the visitor. If the resident allows entry, they are switched back to the call in progress.
 - 3 If the resident dials a *, entry is denied and the phone switches back to the call in progress.
 - 3 If the resident receives a normal phone call while talking with a visitor, two short tones signal the incoming call. Dialing a 2 puts the visitor on hold and switches to the normal telephone call, and dialing another 2 switches back to the visitor.
- 3. Entry codes:** Each resident (and any one else you authorize) can have a unique 4-digit entry code. When entered on the controller (or lobby phone) keypad, the code will open the main door or gate. The Ovation can support up to 3,000 entry codes.
- 4. Door monitoring:** Sensors can be installed to monitor the status of any door the system controls. If a door is forced or held open 60 seconds after it should be closed, the system can respond by:
 - a. Alarm Call (option)*:** The system calls a pre-programmed telephone number and sends a message via modem. If there is no modem at the number, whoever answers will hear a series of tones. Pressing any key on a tone dial telephone acknowledgea receiving the alarm call, and the system connects the answering phone to the system speaker and microphone (or ring the Lobby Phone). If the pre-programmed number does not answer, the system calls the pre-programmed manager lines in order of priority and reports with tones as described above.
 - b. Close a relay:** If relay 2 is programmed as an alarm relay, the system will close that relay to activate any device connected to it (siren, lights, CCTV).

5. **Free exit through a monitored door:** The system can provide free exit through a controlled door or gate, allowing exit without causing a forced open door condition.
6. **Access for the Post Office or Fire Department:** Connections are included in the system to allow post office and fire department access without contacting anyone. These features are connected by the installer and the relevant agency.
7. **Direct operator control of doors/gates (option)*:** Controlled doors or gates can be activated from the manager's or any off site tone dial telephone (*door/gate control requires purchase of the remote programming option*).
8. **Remote Programming (option)*:** The Ovation system can be remotely programmed from the manager's or any outside tone dial telephone.
9. **Remote diagnostics (option)*:** The Ovation system can be accessed via any terminal using a Hayes-compatible modem or PC with terminal emulation software. This allows monitoring of system operating parameters, programmed entry codes, LIB board numbers, and customized directory codes.

* These items do not require the installation of a separate reserved telephone line.

PART 2

SAMPLE INSTALLATION

This section explains the arrangement of Ovation system components in a basic installation.

1. SINGLE ENTRANCE

An Ovation system controlling a single entrance consists of two system components:

1. The Ovation Controller

The controller is located by the entrance which it controls. It is connected with a 4 twisted pair cable to the connector board in the first LIB housing.

2. Line Interface Boards (LIBs)

Each LIB controls up to 12 resident telephone lines (therefore a 55 unit building requires 5 LIBs). Every 10 LIBs (or part thereof) are contained within an LIB housing located by the telephone junction box inside the building. The LIBs are connected in a chain using 8 conductor flat telephone cables with an RJ45 connector on each end. All of the LIBs together are referred to as the LIB stack.

WARNING

The LIB housing is not weather-proof, and **MUST** be installed inside a building.

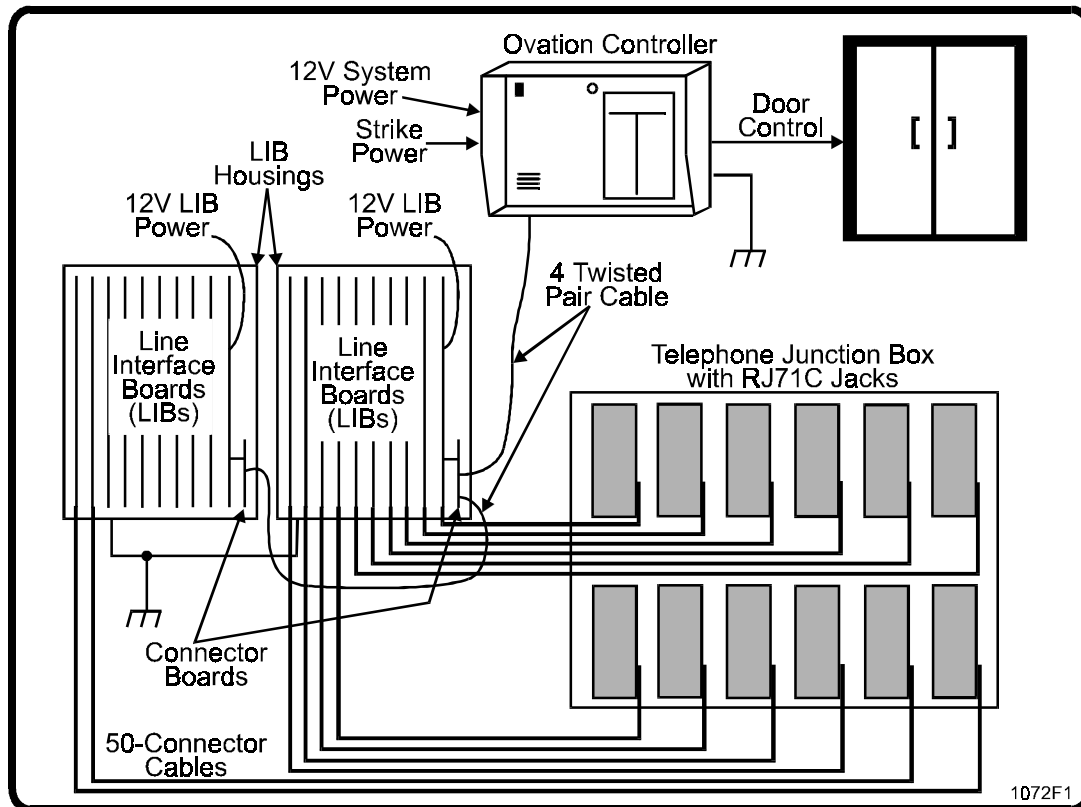

Figure 1. Single Entrance Sample Installation.

2. MULTIPLE ENTRANCES

An Ovation system controlling multiple entrances consists of three system components:

1. The Ovation Controller

Controllers are located by the entrances they control. They are connected by a 4 twisted pair cable to the Multiple Interface Unit in the first LIB housing.

NOTE: MUI and Connector Board are integrated into a single board.

2. Line Interface Boards (LIBs)

Each LIB controls up to 12 resident telephone lines (therefore a 55 unit building requires 5 LIBs). Every 10 LIBs (or part thereof) are contained within an LIB housing located by the telephone junction box inside the building. The LIBs are connected in a chain using 8 conductor flat telephone cables with an RJ45 connector on each end. The first LIB in this stack is connected to the MUI.

WARNING

The LIB housing is not weather-proof, and MUST be installed inside a building.

3. Multiple Unit Interface

Each controller is connected to the Multiple Unit Interface, which can accommodate up to four controllers. The MUI is connected to the first LIB in the LIB stack.

NOTE: Only one controller can be used at a time with this method. This can be avoided by using a separate LIB stack for each controller. When connected in series with telephone company lines (for a four-entrance installation, four RJ71C jacks are installed in series for every 12 resident lines), a visitor at each entrance can simultaneously contact residents in the complex. The disadvantage is the additional cost of separate LIB stacks for each entrance.

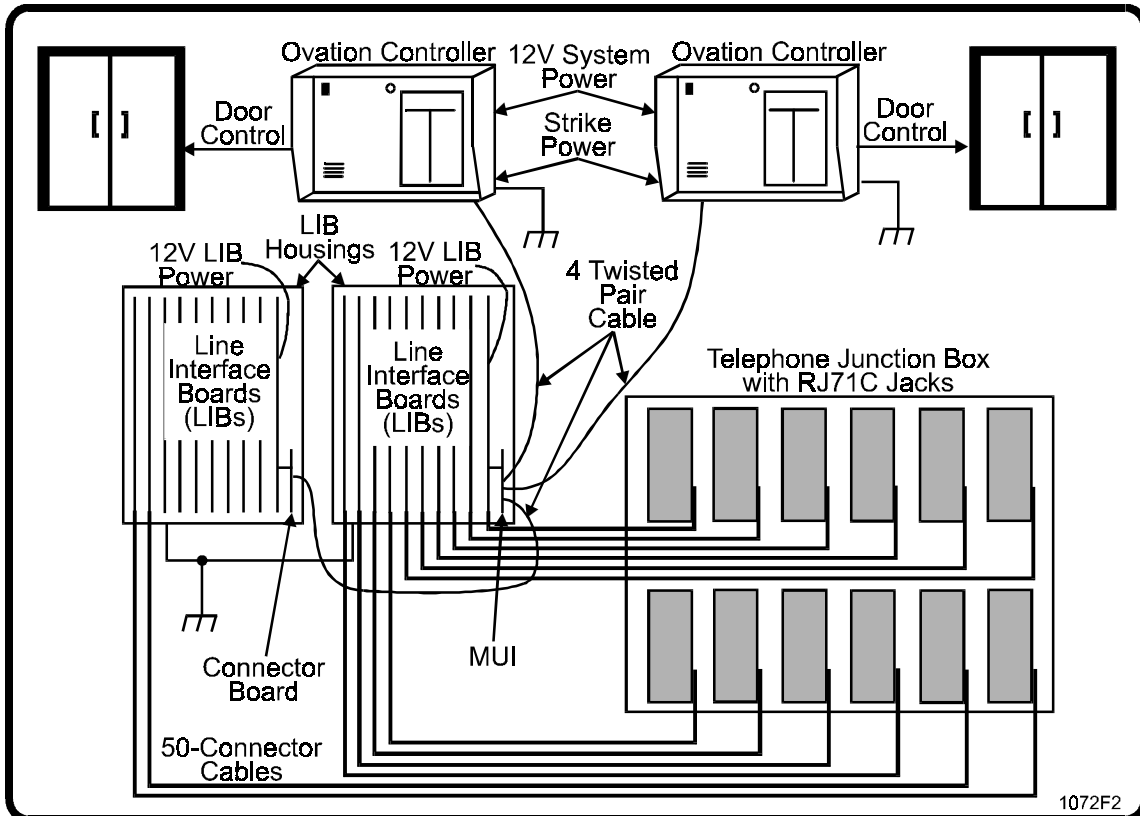

Figure 2. Multiple Entrance Sample Installation.

PART 4

PHONE LINE INSTALLATION

1. ARRANGING TELEPHONE INSTALLATION

Have the telephone company install RJ71C jacks in series, one for each 12 resident phone lines:

1. RJ71C blocks must be installed in an enclosed secured area not subject to weather.
2. **Specify how and where you want them installed, and if possible be present during their installation.** Have them installed close to the LIBs to which they will be connected.
3. **Use the form on the next page to clearly label lines by unit or apartment number,** and give a copy to the telephone company installer. This will help in installation and programming.
4. The telephone company requires the following information to install:

FCC registration number	:DS8 USA-18617-OT-E
Ringer Equivalence Number (REN)	:0.1B
Type of Connector Required	:USOC RJ71C

2. INSTALLING RJ71C JACKS

Place the RJ71C jacks in series with incoming telephone lines so the Ovation can "intercept" the lines when a visitor wants to contact a resident. Install the RJ71C jacks as follows:

1. Each RJ71C jack handles 12 telephone lines, so if you have a 55 unit building, only 5 jacks will be needed. If a unit has more than one phone, connect only the main line through the RJ71C.
2. Connect the first incoming line to pins 1 and 2 on column A ("tip" to pin 1 and "ring" to pin 2). This line goes through the RJ71C to pins 27 and 28 ("tip" to pin 27 and ring to pin "28").
NOTE: Polarity must be maintained for proper telephone function.
3. The second incoming line to goes in on pins 3 and 4 and exits on pins 29 and 30. All 12 lines are wired in the same fashion.
4. Install bridging clips between columns B and C to connect with the 50 conductor cable.

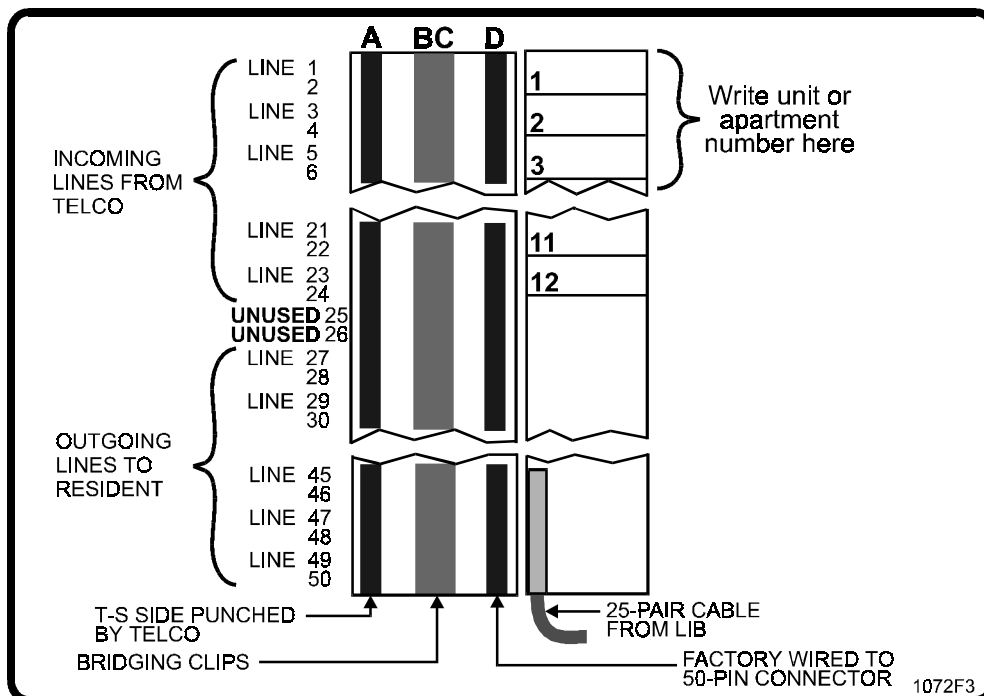

Figure 3. Installing RJ71C Jacks.

PART 5 PULLING CABLES

NOTE

Unshielded cable is acceptable for use in indoor, weather-proof installations. Shielded cable is required if wires will be run outdoors. Recommendations for both types of cable are provided where needed.

1. SINGLE ENTRANCE

A. Ovation Controller Cabling

The following cabling must be run for a single entrance installation:

- a. **A 4 twisted pair cable** from the Ovation Controller to the connector board in the first LIB housing, as shown Figure 5. This cable can be up to 2500 feet in length.
NOTE: Belden 8757 for unshielded installations and Belden 9504 for shielded installations (or equivalent) is recommended.
- b. **A 2 conductor shielded cable** from the Ovation Controller to the 120 VAC outlet for the 12 VAC, 50 VA transformer supplied by Sentex (or a 13.5 VDC power supply that you provide). See Table 1 for the required wire size.
- c. **A 2 conductor cable** to the Ovation Controller from the door strike, magnetic lock, or gate operator for each of the 2 control relays.
- d. **A 2 conductor cable** to the Ovation Controller from the strike power supply, if required.
- e. **Wiring for additional features** as required. See Part 9 for details of the cabling required.

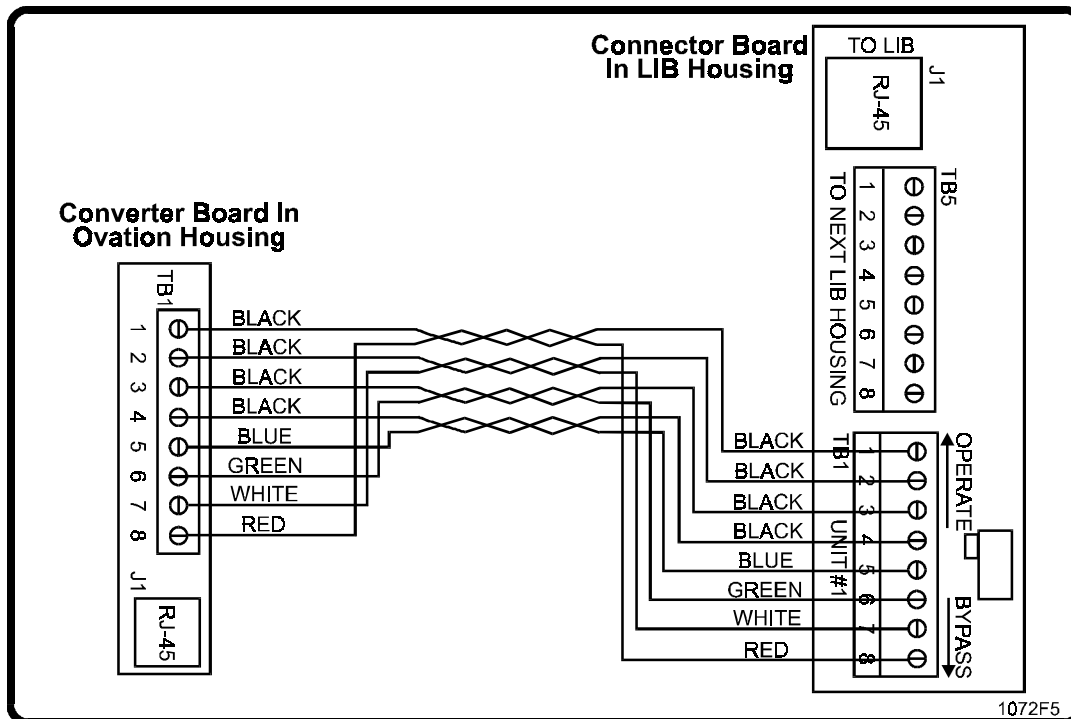

Figure 5. Single Entrance Ovation Controller Cabling.

DC POWER WIRE SIZE	DISTANCE	AC POWER WIRE SIZE
18 AWG	30' and under	18 AWG
18 AWG	30'-75'	14 AWG
14 AWG	75'-150'	12 AWG
12 AWG	150'-250'	10 AWG
10 AWG	250'-500'	-----

Table 1. Single Entrance Ovation Cabling Power Wire Distance.

B. Line Interface Board Cabling

The following cabling must be run for a single entrance installation:

- a. **A 2 conductor shielded cable** from the LIB to the 120 VAC outlet for the 12 VAC, 50 VA transformer supplied by Sentex (or a 12 VDC power supply that you provide). See Table 2 for the required wire size.
 - b. **A 4 twisted pair cable** between the connector boards of each LIB housing in the stack, as shown in Figure 6 (applies only to installations with multiple LIB housings).
- NOTE:** Belden 8757 for unshielded installations and Belden 9504 for shielded installations (or equivalent) is recommended.

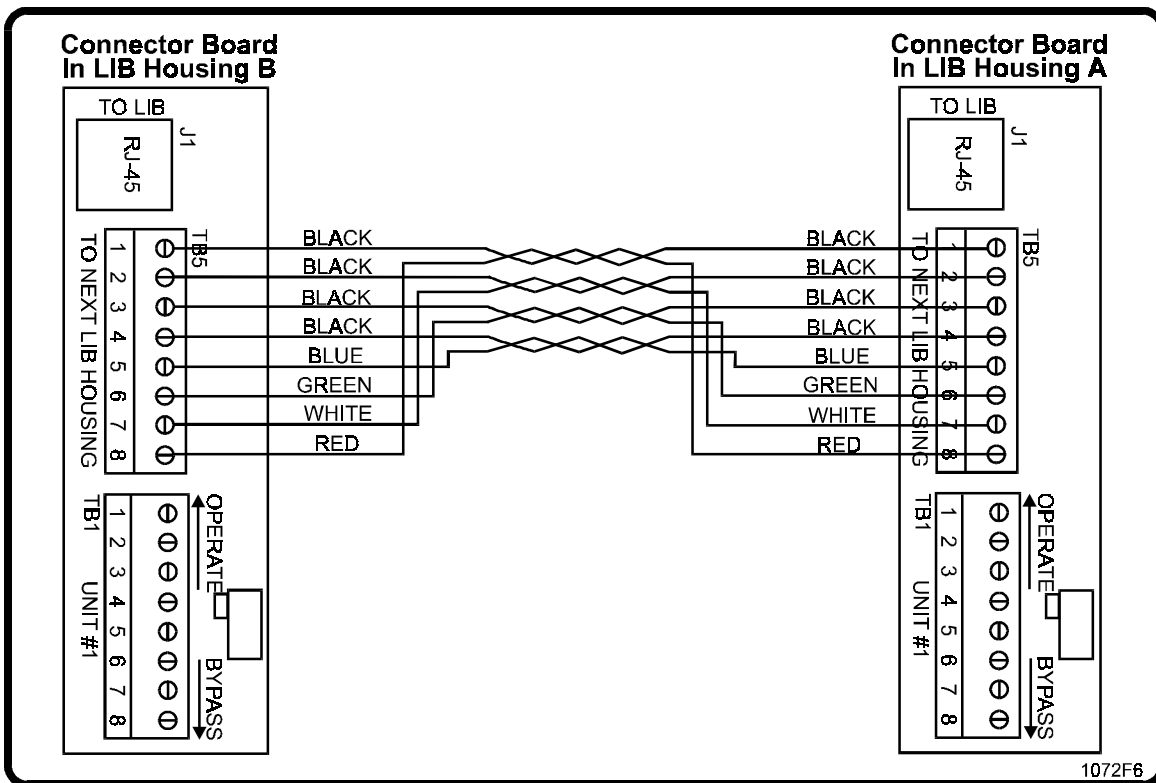

Figure 6. Single Entrance LIB Cabling.

DC POWER WIRE SIZE	DISTANCE	AC POWER WIRE SIZE
18 AWG	30' and under	16 AWG
18 AWG	30'-75'	12 AWG
14 AWG	75'-150'	10 AWG
12 AWG	150'-250'	-----
10 AWG	250'-500'	-----

Table 2. Single Entrance LIB Cabling Power Wire Distance.

2. MULTIPLE ENTRANCES

A. Ovation Controller Cabling

The following cabling must be run for a multiple entrance installation:

- A 4 twisted pair cable** from the Ovation Controller to the MUI located in the first LIB housing, as shown in Figure 7. This cable can be up to 2500 feet in length. Each additional Ovation controller must be wired to the corresponding unit number on the MUI.
NOTE: Belden 8757 for unshielded installation and Belden 9504 for shielded installations (or equivalent) is recommended.
- 2 conductor shielded cables** from each Ovation Controller to the 120 VAC outlets for the 12 VAC, 50 VA transformers supplied by Sentex (or a 13.5 VDC power supplies that you provide). See Table 3 for the required wire size.
- 2 conductor cables** from the Ovation Controller to the door strikes, magnetic locks or gate operators for the 2 control relays on each controller.
- 2 conductor cables** from the strike power supplies, if required.
- Wiring for additional features** as required. See Part 9 for details of the cabling required.

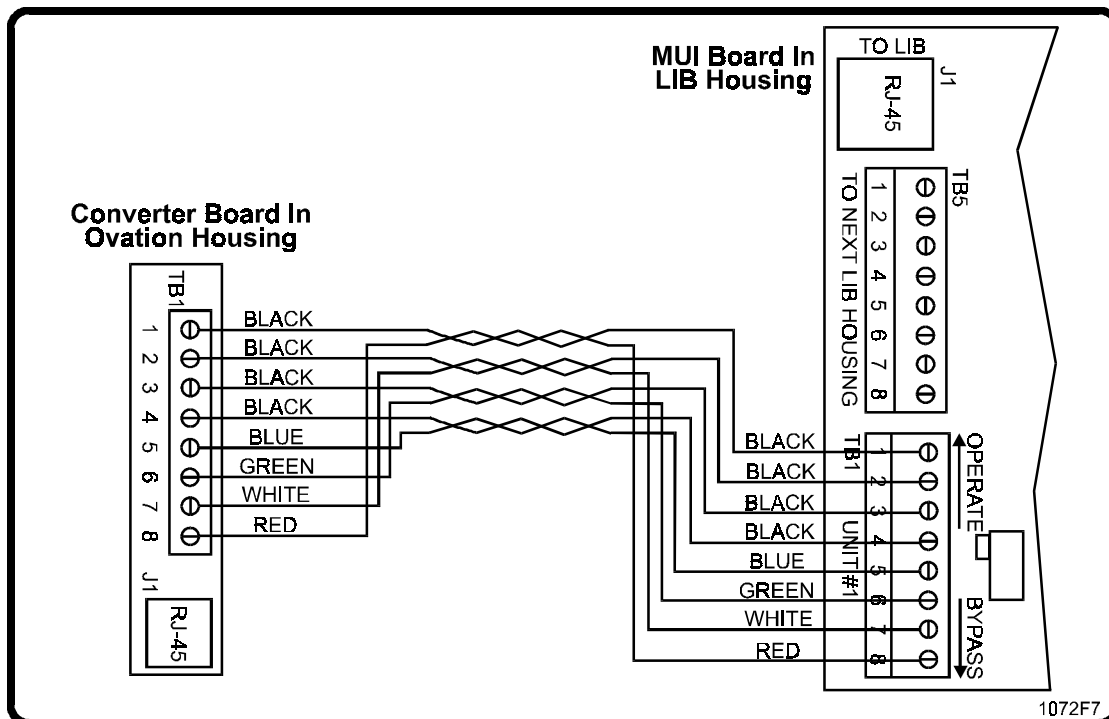

Figure 7. Multiple Entrance Ovation Controller Cabling.

DC POWER WIRE SIZE	DISTANCE	AC POWER WIRE SIZE
18 AWG	30' and under	18 AWG
18 AWG	30'-75'	14 AWG
14 AWG	75'-150'	12 AWG
12 AWG	150'-250'	10 AWG
10 AWG	250'-500'	-----

Table 3. Multiple Entrance Ovation Cabling Power Wire Distance.

B. Line Interface Board Cabling

The following cables must be run for a multiple entrance installation:

- 2 conductor shielded cable** from the LIB to the 120 VAC outlets for the 12 VAC, 20 VA transformers supplied by Sentex (or a 12 VDC power supplies that you provide). Up to 10 LIB's may be powered by each transformer. See Table 4 for the required wire sizes.
- 4 twisted pair cable** between the connector boards of each LIB housing in the stack, as shown in Figure 8. Refer to the figure for which pairs that need to be twisted for a multiple unit installation with multiple LIB housings (diagram applies only to installations with multiple LIB housings).

NOTE: Belden 8757 for unshielded installations and Belden 9504 for shielded installations (or equivalent) is recommended.

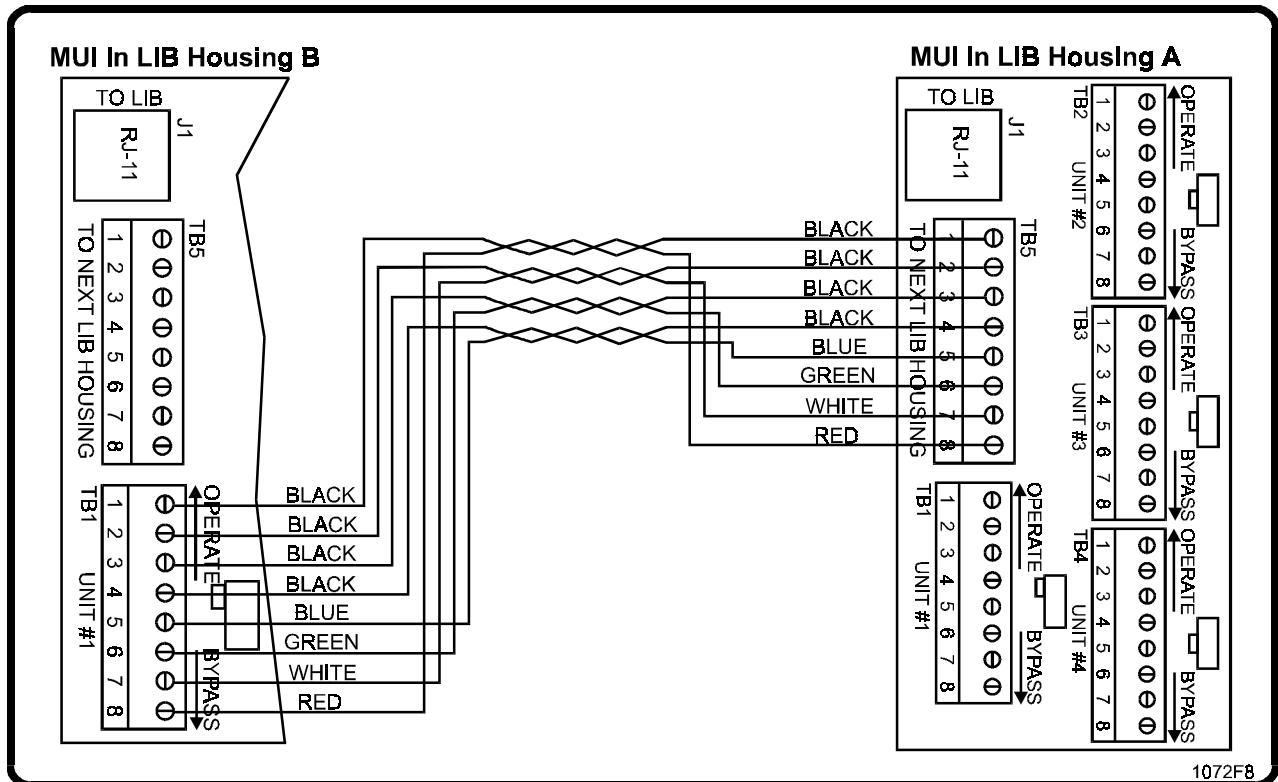

Figure 8. Multiple Entrance LIB Cabling.

DC POWER WIRE SIZE	DISTANCE	AC POWER WIRE SIZE
18 AWG	30' and under	16 AWG
18 AWG	30'-75'	12 AWG
14 AWG	75'-150'	10 AWG
12 AWG	150'-250'	-----
10 AWG	250'-500'	-----

Table 4. Multiple Entrance LIB Cabling Power Wire Distance.

PART 6

MOUNTING THE CABINETS

1. OVATION "S" AND "V" MODEL CABINETS

- "S" and "V" model cabinets should be mounted near the entrances they will control.
 - For multiple entrance installations, choose locations near each entrance.
1. Determine which "knock-outs" you will use.
 2. Disconnect the keypad from the main circuit board and remove the board(s) from the cabinet.

CAUTION

When removing the keypad from its socket on the main board, do not grab the connector directly or you may break a connector pin. Grasp the cable just below the connector, and with your thumb over the connector, gently rock it from side to side while pulling on the cable.

3. Remove the desired knock-out.
4. Mount the unit on the wall:
 - a) Surface Mount Cabinets: Install the two top screws/bolts in the wall, leaving them loose. Hang the cabinet on the installed screws/bolts. Install the bottom screws/bolts in the bottom openings. Tighten all four screws/bolts.
 - b) Flush Mount Cabinets: Cut hole in wall (see Figure 9 for dimensions). Place cabinet in wall. Install and tighten ten screws to secure cabinet to wall.
5. Pull all necessary wires into the cabinet. **NOTE:** If using bottom knockout, attach conduit first.
6. Ground the enclosure(s). See Appendix 1 for grounding screw location.
7. Replace the circuit boards. **NOTE:** If using lower left knock-out, route wires beneath boards.

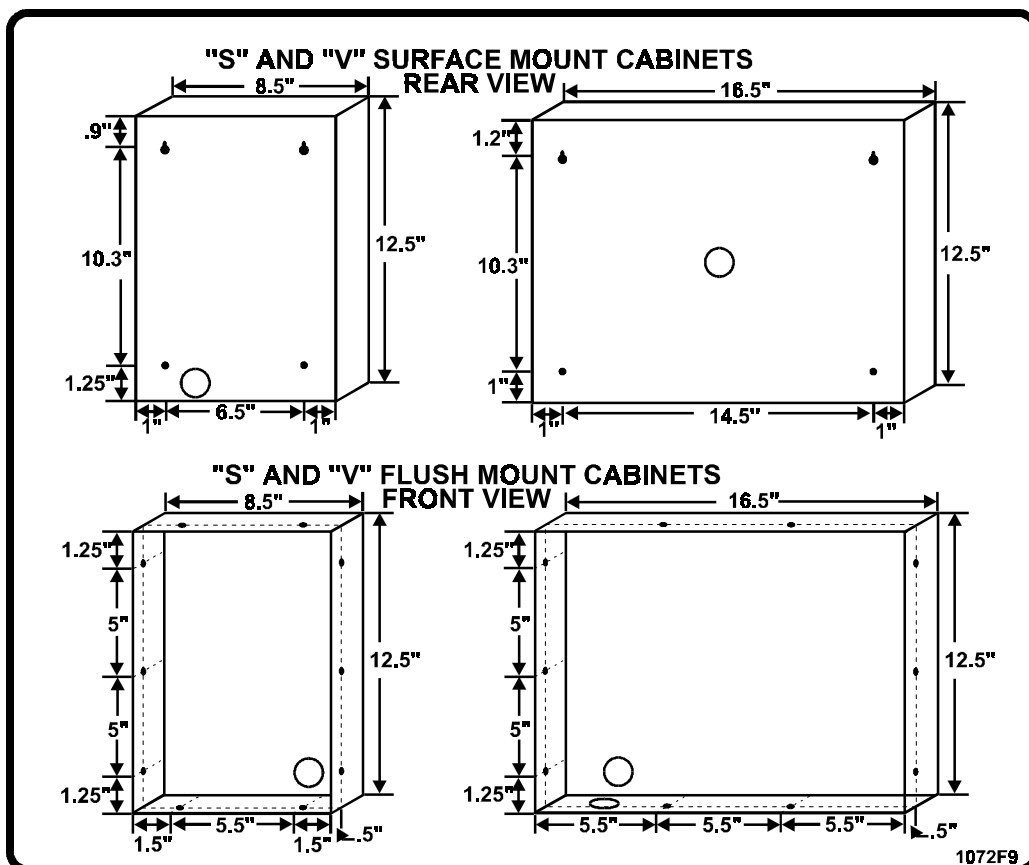

Figure 9. Mounting Ovation "S" and "V" Cabinets.

2. LINE INTERFACE BOARD (LIB) HOUSINGS

- Mount the LIB housings as close as possible to the RJ71C jacks to simplify installation.
 - Fifteen foot connector-end cables are available from Sentex.
 - Longer connector-end cables may be special-ordered from Sentex.
1. Remove the LIB circuit boards from their housing(s).
Note: Each LIB is held in place by its own grounding screw at the top of the housing.
 2. Mount the LIB housing(s) on the wall:
 - a) Install the two top screws/bolts in the wall, leaving them loose.
 - b) Hang the cabinet on the installed screws-bolts.
 - c) Install the bottom screws/bolts in the bottom openings.
 - d) Tighten all four screws/bolts.
 3. Ground the housing to a suitable earth ground using the ground connection located on the upper right side of the LIB housing.
 4. Set the LIB addresses as described in Part 7.
 5. Reinstall the LIBs and secure with grounding screws.

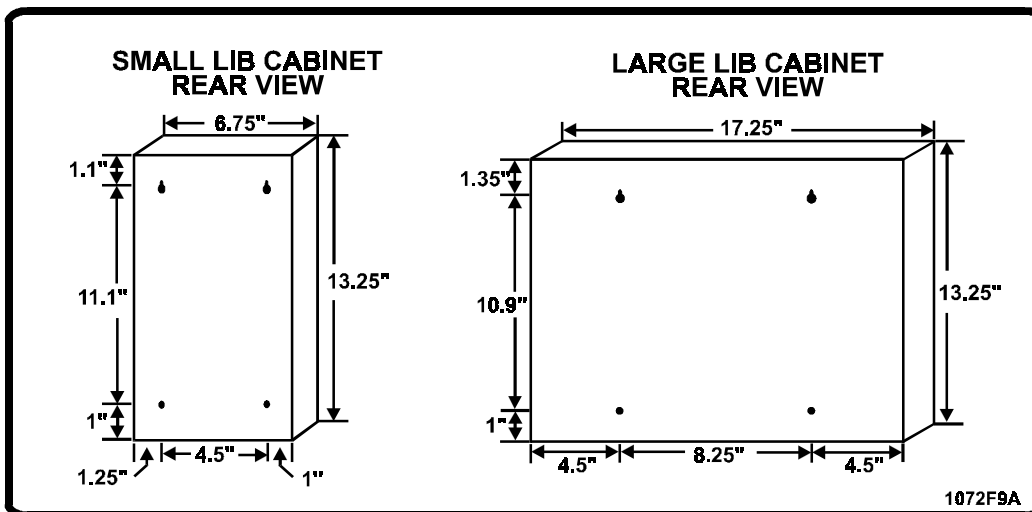

Figure 10. Mounting LIB Cabinets.

PART 7

SETTING LIB ADDRESSES

- Each Line Interface Board (LIB) must have a unique 3 digit address number to operate properly with the Ovation system. These addresses are set using the "decade" switch (or switches) located at the top of the LIB (see Figure 11).

IMPORTANT NOTE

Address numbers take the place of the telephone numbers you would program into a normal telephone entry system. **If LIB address numbers are duplicated, the Ovation system will operate incorrectly.**

- There are two different types of LIBs: Single decade switch and three decade switch types. The switches are located in the upper right-hand corner of both types of boards. In order to properly set the LIB addresses, please refer to the appropriate section for your installation.

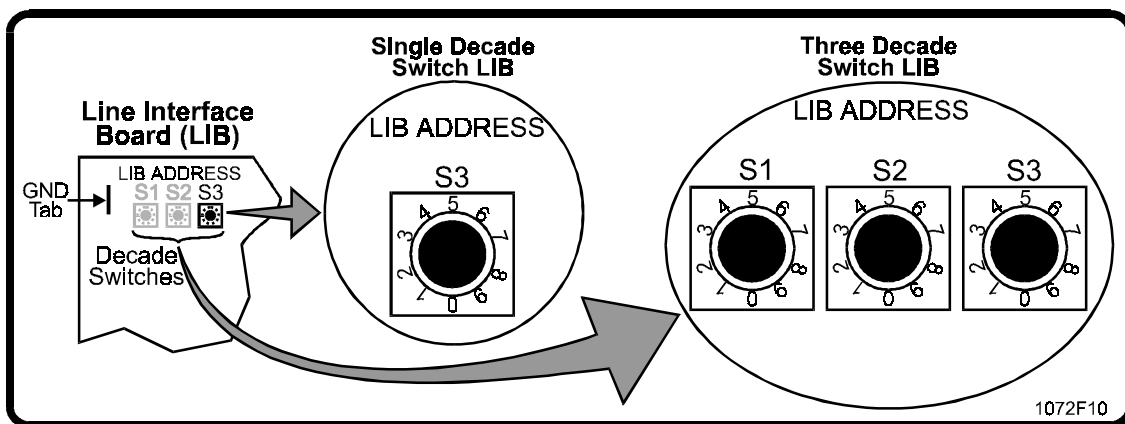

Figure 11. LIB Types and Decade Switch Arrangements.

1. SINGLE DECADE LIB SWITCH

Single decade switch LIBs should be used only when there are 10 or less LIBs in your installation. Set single decade switch LIB addresses as follows:

- Set LIB address numbers by working from right to left, starting with the number 0. For a 10 LIB installation, the decade switch on the the far right LIB will be "0" and the decade switch on the far left LIB will be "9".
- When programming a single switch LIB, the first two numbers are considered to be "00". So the LIB address for the second LIB from the right will be "001".

Once LIB addresses are set, finding individual line addresses is easy. In a 10 LIB installation:

- The third line on the second LIB from the right will have an address of 00103, because 001 is the LIB number and 03 is the line number.
- Tthe fourth line on the tenth LIB will have an address of 00904, because 009 is the LIB number and 04 is the line number.

2. THREE DECADE LIB SWITCH

To make service and troubleshooting easier, we recommend organizing three decade switch addresses as follows:

1. Switches S1 and S2 indicate the LIB housing number. For example

- On boards in the *first LIB housing of a stack*, set S1 to 0 and S2 set to 1.
- On boards in the *thirteenth LIB housing of a stack*, set S1 to 1 and S2 set to 3.

NOTE: If there is only one LIB housing in your installation, set S1 and S2 on all LIBs to 0. This allows you to use a 3 digit default directory code: 1 digit for the LIB and 2 digits for the LIB line address.

2. Switch S3 indicates the LIB number within the housing. Number from right to left, starting with 0. For example:

- On the far right LIB in the housing, set S3 to 0.
- On the LIB to its left, set S3 to 1, and so on.
- Using this numbering scheme, the address of the fourth LIB from the right in the second LIB housing is 023, because 02 is the *housing* number, and 3 is the *LIB* number.

Once the LIB addresses are set, determining the address of individual lines is easy. For example:

- ◆ The third line on the the fourth LIB from the right in the second LIB housing is addressed 02303, because 02 is the *housing* number, 3 is the *LIB* number, and 03 is the *line* number.
- ◆ The eleventh line on that same board would have an address of 02311, because 02 is the *housing* number, 3 is the *LIB* number, and 11 is the *line* number.
- ◆ The same line addressing scheme is used on all boards. So the eighth line on the fifth board from the right in the first LIB housing would have an address of 01408, because 01 is the *housing* number, 4 is the *LIB* number, and 08 is the *line* number.

NOTE: These addresses are necessary to program and troubleshoot the system. Make sure they are labeled on the associated RJ71C jack, and entered on the form in Figure 4, so they will be available to assist you in programming, testing and troubleshooting the system.

PART 8

MAKING BASIC CONNECTIONS

1. OVATION CONTROLLER CONNECTIONS

NOTE: Refer to Tables 1-4 for wire sizes and run distances for the following procedures.

A. Door/gate control

Refer to Figure 12 and connect the wires from Ovation-controlled devices as follows:

- Relay/door 1 TB 5
- Relay/door 2 TB 6

Which terminals are used depends on the type of device being controlled:

- ◆ **Dry Contact Closures (most gate operators):** Connect one wire to the NO terminal and the other to COMMON.
- ◆ **Normally Locked Strikes:** Connect one wire from the strike power supply to the NO terminal and one wire from the door strike to COMMON on the same terminal block. Connect the remaining wires from each source off the board with a wire nut.
- ◆ **Magnetic Locks and Normally Unlocked Strikes:** Connect one wire from the power supply to the NC terminal and one wire from the door strike to COMMON on the same terminal block. Connect the remaining wires from each source off the board with a wire nut.

NOTE: Magnetic locks and DC powered strikes produce potentially damaging voltage spikes. Sentex strongly recommends installing an IN4001 diode across the magnetic lock coil with the cathode (the banded end) connected to the positive side of the coil, and the anode connected to the negative side of the coil.

B. LIB Control:

- ◆ **Single Unit Installations:** Plug the 4 twisted pair cable from the Ovation converter board into TB1 on the connector board in the first LIB housing.
- ◆ **Multiple Unit Installations:** Plug the 4 twisted pair cable from the Ovation converter board into TB1 on the MUI in the first LIB housing. Plug the four twisted pair cables from additional Ovation controllers to the corresponding unit numbers on the MUI.

NOTE: The MUI can accommodate up to four Ovation controllers.

C. Ovation Controller Power

AC POWER: Connect the two wire shielded cable to TB8 on the Ovation main processor board (polarity is unimportant) and to the transformer provided with the system.

DC POWER: Connect one end of a two wire shielded cable to TB8 on the main processor board (polarity is unimportant) and the other end to the DC power supply.

- ◆ **DC Power** must be at least 13.5 Volts.
- ◆ **UPS:** Since the Ovation will not charge a battery, DC power must be supplied by an uninterruptible power supply.
- ◆ **Line Loss:** If system and power supply are too far apart, line loss may result in inadequate voltage being delivered to the system. Refer to Table 1 for wire sizes and distances.

CAUTION: High voltages are present in the power supply area of the controller board when power is connected. Do not apply power until all system connections have been made.

When power is applied, the Power indicator on the bottom left of the Ovation board will light.

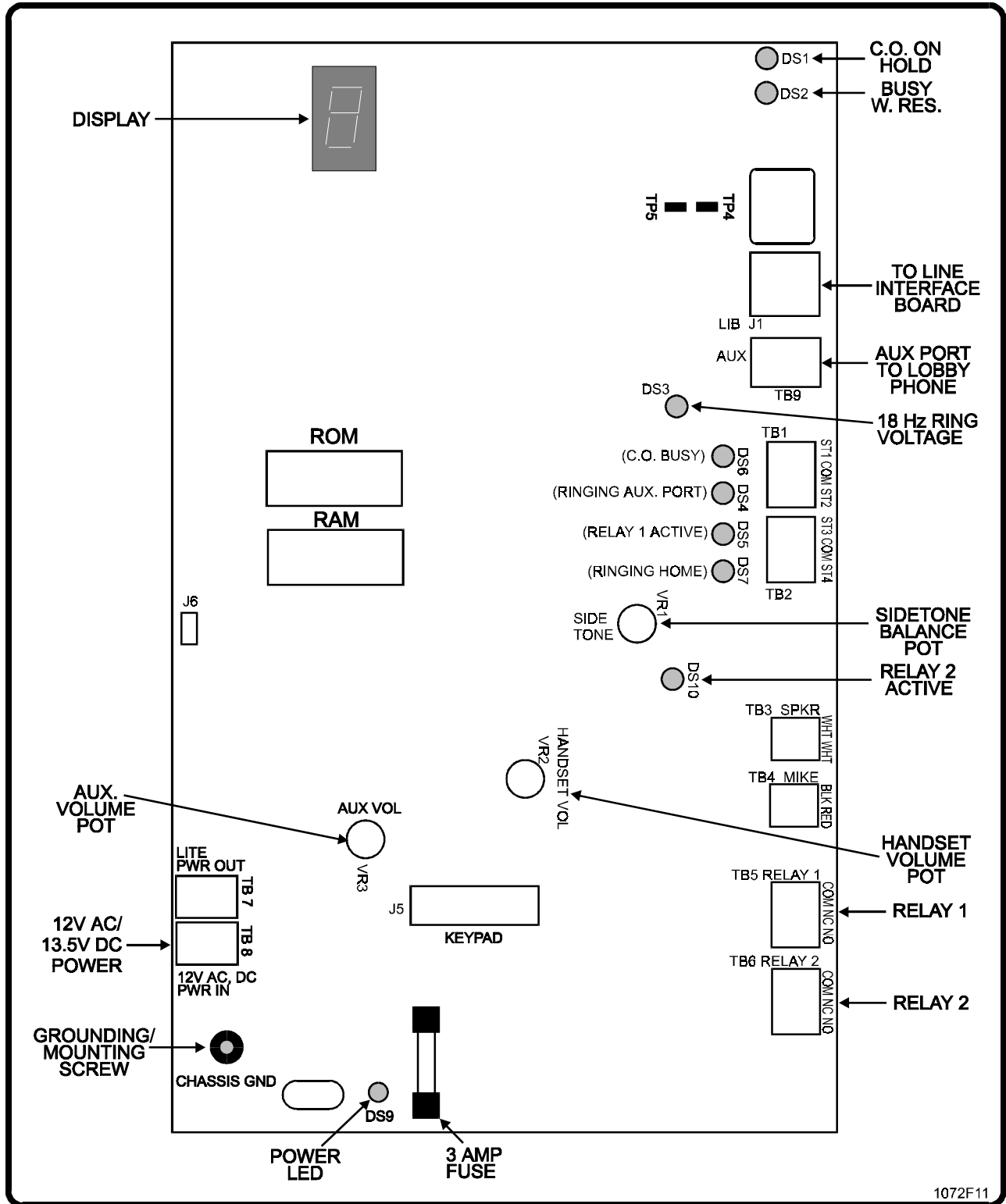

Figure 12. Ovation Controller Board Connections, Adjustments and Indicators.

2. LIB CONNECTIONS

IMPORTANT NOTE

If the Ovation system is used in conjunction with an alarm system, the telephone line **MUST** encounter the alarm system first, then the RJ71Cs, and then the Ovation Controller (see Figure 13). If the system is not connected in this order, it will cause erratic problems with both the alarm and Ovation systems.

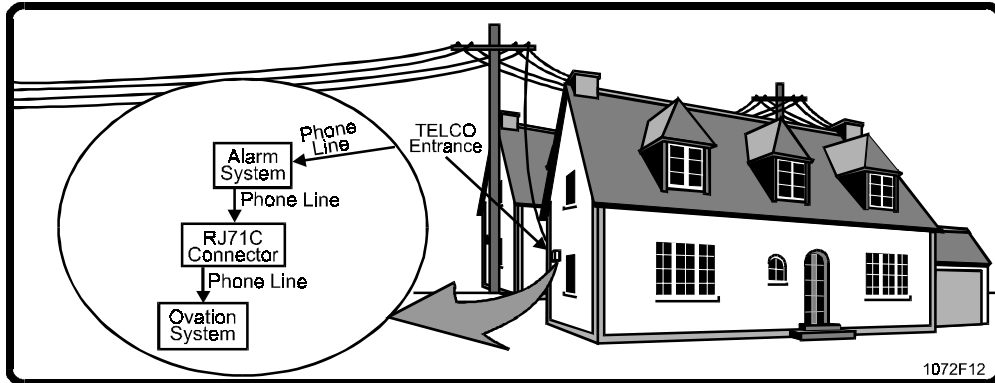

Figure 13. Connecting Alarm and Ovation Systems.

1. RJ71C Connectors

1. Remove the shorting block from the first RJ71C connector.

NOTE: Keep all shorting blocks with their RJ71C connectors. Should the LIBs become damaged or disconnected, reinstalling the shorting blocks on their RJ71C connectors will restore normal telephone operation.

2. Connect a 50 conductor cable with a 50 pin connectors from the associated LIB to the RJ71C connector block.
 - Fifteen foot connector-end cables are available from Sentex.
 - Longer connector-end cables may be special-ordered from Sentex.
3. Repeat steps 1 and 2 for each RJ71C and associated LIB.

IMPORTANT NOTE

If any residents have 3-way calling, either their 3-way calling service or the optional Ovation call-waiting feature must be discontinued. Otherwise, when call-waiting is activated, the Ovation will trigger the 3-way calling feature and the tenant will be connected to a dial tone. To discontinue call waiting for a single resident, see the enclosed manual entitled "Instructions For The Programming And Use Of The Ovation System".

2. LIB Power

1. Connect the power cable from the supplied 12VAC transformer (or 13.5 VDC power supply you provide) to TB2 (IN) on the first LIB.
2. Connect TB1 (OUT) of the first LIB to the TB2 (IN) of the next LIB in the chain.
3. Continue until all LIBs in a cabinet are connected.

CAUTIONS

1. Do not apply power until all connections have been made. When power is applied to the LIBs, all LIB POWER indicators should light (see Figure 14).
2. The Ovation, door strikes, and LIBs must each be powered by separate transformers.
3. Do not overload LIB transformers by connecting more than one cabinet (10 LIBs).

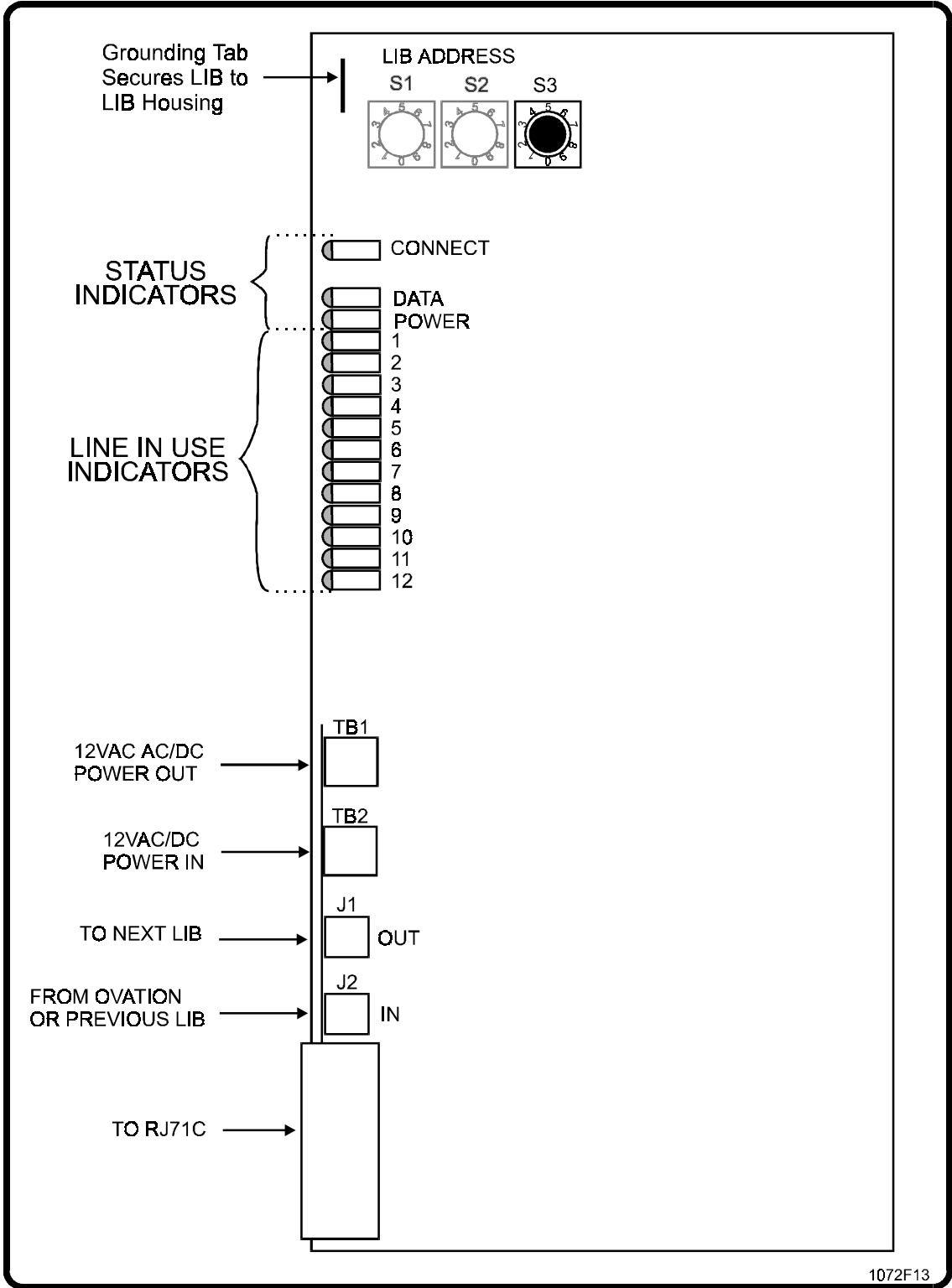

1072F13

Figure 14. LIB Connections and Indicators.

3. LIB Control

1. **Single Unit Installations:** Connect the 4 twisted pair cable from the Ovation controller to TB1 on the connector board in the first LIB housing (see Figure 15).
Multiple Unit Installations: Connect the 4 twisted pair cable from the Ovation controller to TB1 on the MUI in the first LIB housing (see Figure 15).
2. Connect all LIBs in the housing using the short 8-conductor cables with RJ45 connectors (provided with the LIBs). Connect them from J1 (OUT) of one LIB to J2 (IN) of the next LIB.
3. Repeat step 2 until all LIBs in the housing are connected.
4. **For Multiple LIB Housings:** connect a 4 twisted pair cable from TB5 on the MUI in the first housing to TB1 on the MUI in the next housing.
5. Continue until all LIB housings are connected. After you have finished connections, apply power. When the controller and LIBs are powered up, the POWER indicator will light on all the LIBs in the stack (see Figure 14).

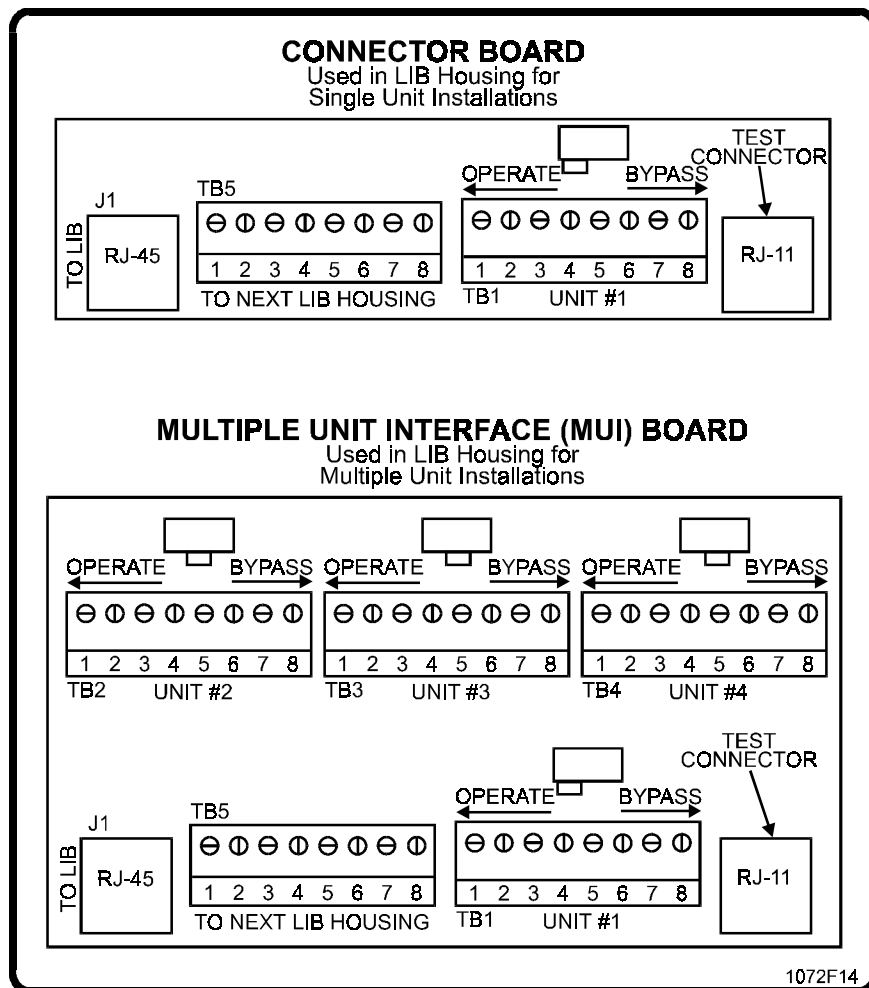

Figure 15. Connector Board and MUI Board Connections.

PART 9

INSTALLING ADDITIONAL FEATURES

The following features are connected in the same fashion for the "S" or "V" models, regardless of single or multiple entrance installations.

1. POSTAL LOCK

- ◆ The Post Office requires installation of their own lock where mail-boxes are inside a controlled area.
- ◆ Your customer must arrange with the postal carrier to have a postal lock installed before the postal lock kit can be installed.
- ◆ A kit for wiring the postal lock switch is provided with each system. Specific directions for connecting these parts to "ST1" and "COM" on TB1 are included in the postal lock kit.
- ◆ Once installed, when the postal carrier turns the key in the lock, the system activates relay 1 for the programmed period of time.

2. AUX OPEN/REQUEST FOR ACCESS

- ◆ Any device such as a Knox box or exit button providing a contact closure can be wired to the Ovation to provide access.
 - Devices wired to ST1 and COM on TB1 activate Relay 1.
 - Devices wired to ST3 and COM on TB2 activate Relay 2 (if Relay 2 is set as a control).
- ◆ Use shielded cable such as Belden 8771, with the shield connected to the Controller board ground screw. When contact closure occurs, the system activates the associated relay for the programmed period of time.

3. DOOR POSITION SENSING

The Ovation can monitor the position of two doors and act based on their status. If a door is pried open, or is held open for more than a minute after its relay deactivates, the system can call a telephone number and report its condition, and/or close a relay to activate a device such as a camera, siren, etc. To use this feature:

1. Install a normally closed switch in the door frame so it is depressed when the door is closed.
2. Wire the normally closed (NC) and common (COM) terminals of the switch to:
 - ST2 and COM on TB1 (for door 1).
 - ST4 and COM on TB2 (for door 2).
3. Use shielded cable such as Belden 8771 and ground the shield to the Ovation controller board ground screw shown in Figure 12.

PART 10

TESTING AND ADJUSTING THE UNIT

To ensure proper operation, the following procedures must be performed, and may also be helpful in troubleshooting the system after installation. For more detail, refer to the "Programming and Use Instructions for the Ovation system" manual.

1. VERIFYING CODE CAPABILITIES

1. Verify that all LIBs are set properly and there is no duplication of 3-digit LIB addresses.
2. To ensure the entry codes feature works properly, on the controller keypad, enter the programming mode board by entering three asterisks ("***") followed by the six digit user defined password (factory setting is 000000).
3. Enter programming step 08 and set the relay activation time for relay 1 followed by the "#" sign. The relay activation time can be entered any two-digit number from 01 and 99 seconds.
4. Enter programming step 16 and enter a four digit entry code followed by the "#" sign.
5. Enter the entry code programmed in step 4 on the front entrance Ovation, verify access is granted for the correct length of time, and verify that the Ovation emitted 10 beeps.

2. ADJUSTING SIDETONE BALANCE

1. Place a volt meter on TP4 (+) and TP5 (-) of the Ovation controller board (see Figure 12).
2. Enter the programming mode by entering three asterisks ("***") followed by the six digit user defined password (factory setting is 000000).
3. Enter programming step "69" followed by the three-digit LIB number, the two-digit line number of the line you wish to use for this test, and the "#" key. When you hear the tone, adjust the "SIDETONE BALANCE" pot on the Ovation controller board to minimize the DC voltage between these two points.

3. VERIFYING TELEPHONE AND DOOR/GATE CONNECTIONS

1. Incoming Line Test

- ◆ To verify system connections, each resident's phone and outgoing line must be tested. You will need a standard tone dial telephone and cord with RJ11 connectors on both ends.
1. Plug your test telephone into the test connector on any MUI, lift the handset and dial "***5". A beep will indicate you are in a limited programming mode (you may only do the areas described on this page and the next). See Figure 14 for location of the MUI test connector.
 2. After you hear the beep, enter "23" followed by the 3 digit LIB address and the 2 digit line address of the unit you wish to contact, followed by a "#".
 3. Hang up the handset. The test phone and resident's phone will ring simultaneously. Do not answer the test set until ringing stops (the resident has answered) or you decide no one is going to answer (ringing stops when you pick up the handset). If the resident answers, pick up your handset and confirm their identity.
 4. After talking to the resident (or picking up the handset to stop ringing), hang the handset up
 5. Repeat for each resident starting at Step 1. If no one answers the phone, note this on the "LIB planning form" in Figure 4 and ensure these lines operate properly when a resident is in.

2. Outgoing Line Test

1. Plug your test telephone into the test connector on any MUI, lift the handset and dial "***5". A beep will indicate you are in a limited programming mode (you may only do the areas described on this and the last page). See Figure 15 for location of the MUI test connector.
2. After you hear the beep, enter "24" followed by the 3 digit LIB address and the 2 digit line address of the unit you wish to contact, followed by a "#". This cuts into resident's phone line. If the resident is on the phone, you will be on the line with them and the incoming telephone line. Verify the connection is correct. If the resident is not on the phone, you will hear their dial tone. Note this number on the "LIB planning form" in Figure 4 and ensure these lines operate properly when a resident is in.
3. Repeat Steps 1 and 2 for each line.
 - ◆ Verify that each resident's telephone line is functioning properly within the building. In cases where the resident has no telephone service, no dial tone should be heard.

3. Door/Gate Connections

1. To test door/gate connections, call a resident from the Ovation. When the resident answers, identify yourself and ask them to press "9" on their telephone.
2. Verify the device attached to relay 1 activates for the specified period of time and that 10 beeps are emitted from the front panel speaker.
3. If there is a second door or gate connected to relay 2, call a resident from the keypad located at the front entrance to the building/complex. When the resident answers their telephone, identify who you are and ask them to press a "5" on their telephone keypad.
4. Verify that the device attached to relay 2 activates for the specified period of time and that 10 beeps are emitted from the front panel speaker.

4. AUDIO ADJUSTMENT

Test system audio by establishing communications with a resident or the building manager. Make the following adjustments only if necessary:

1. **Handset or Speaker Volume:** If the volume at the system is too loud or soft, you can adjust it by turning the "HANDSET VOLUME" adjustment pot shown in Figure 12 (for handset models) or the "SPKR VOL" adjustment pot shown in Figure 16 (for hands-free systems).
2. **Audio Continuity:** If the audio on a hands-free system is "clipping", have the called party speak while you adjust the "TENANT BIAS" pot (see Figure 15) in small increments. Adjust the pot clockwise if the resident's voice is clipping and counter-clockwise if the visitor's voice is clipping, until communications are clear. **Note:** Pot is normally set in the center of its range.

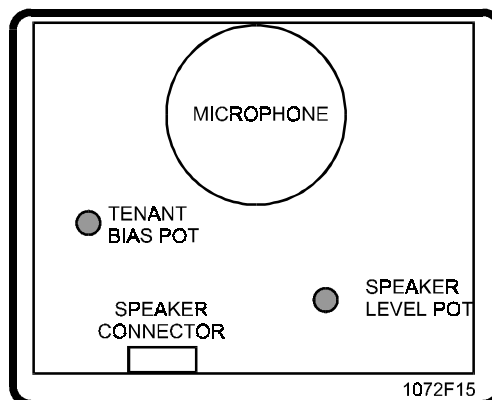

Figure 16. Hands Free Board Adjustments.

PART 11

GLOSSARY OF DIAGNOSTIC INDICATORS

1. OVATION CONTROLLER BOARD

The Ovation controller board has a number of indicator lights to help you determine the status of the board and whether it is installed correctly. See Figure 12 for indicator locations.

C.O. ON HOLD (DS1): This indicator lights when the Ovation controller has a resident's TELCO line on hold during call waiting.

BUSY WITH RES. (DS2): This indicator lights when the resident is in contact with the visitor entrance.

18Hz RING VOLTAGE (DS3): This indicator flashes when the controller rings any telephone.

RINGING AUX PORT (DS4): This indicator flashes when the controller rings the Lobby Telephone (Aux telephone port).

RELAY 1 ACTIVE (DS5): This indicator remains lit while Relay 1 is activated for the programmed time.

C.O. BUSY (DS6): This indicator lights when the controller calls an outside telephone number (i.e., not a resident).

RINGING HOME (DS7): This indicator flashes when the controller is ringing a resident.

POWER ON (DS9): This indicator lights if power is connected to the system.

RELAY 2 ACTIVE (DS10): This indicator remains lit while Relay 2 is activated for the programmed time.

2. LINE INTERFACE BOARD (LIB)

Line Interface Boards also have indicators. See Figure 14 for indicator locations.

CONNECT: This indicator lights while the LIB connects the controller to a resident's line, or during testing with program steps 24 and 25. While a resident's phone line is connected one of the twelve line in use indicators will also light.

DATA: This indicator lights only when "line selection tones" are being received from the controller.

POWER: This indicator lights whenever power is connected to the LIB.

1 thru 12: These indicators light when a line is in use. Only one line indicator on the LIB stack should be lit at one time.

FCC REQUIREMENTS

1. INSTALLATION

This equipment complies with part 68 of the FCC rules on the front inside of the cabinet is a label which contains the following information:

1. The FCC registration number for the system, which is DS8 USA-18617-OT-E.
2. The ringer equivalence number (REN) which is 0.1B.

This system connects to the telephone lines by means of a standard jack called the USOC RJ71C. This jack would be installed by the telephone company.

The REN is used to determine the quantity of devices which may be connected to the telephone line. Excessive REN's on the telephone line may result in devices not ringing in response to an incoming call. The sum of the REN's should not exceed five (5.0). To be certain of the number of devices that may be connected to the line, as determined by the total REN's, contact the telephone company to determine the maximum REN's for the calling area.

2. TYPE OF SERVICE

Your Sentex Ovation system is designed to be used on a standard device telephone lines. The system should not be connected to coin service or party lines. If you have any questions about your telephone line, such as how many pieces of equipment may be connected to it, the telephone company will provide this information upon request.

3. TELEPHONE COMPANY PROCEDURES

The goal of the telephone company is to provide you with the best service it can. In order to do this, it may occasionally be necessary for them to make changes in their equipment, operations, or procedures. If these changes might affect your service the operation of your equipment, the telephone company will give notice, in writing, to allow you to make changes necessary to maintain uninterrupted service.

4. IF PROBLEMS ARISE

If your telephone equipment is not operating properly, you should immediately remove it from the telephone lines, as it may cause harm to the network. If the telephone company notes a problem, they may temporarily discontinue service. When practical they will notify you in advance of the discontinuation. If advance notice is not feasible, you will be notified as soon as possible. When you are notified, you will be given the opportunity to correct the problem and informed of your right to file complaint with the FCC.

In the event any repairs are ever needed on your system, they should be performed only by an authorized representative of Sentex Systems, Inc.

5. RADIO FREQUENCY

This equipment has been tested and found to comply with the limits for a Class B digital device, pursuant to part 15 of the FCC Rules. These limits are designed to provide reasonable protection against harmful interference when the equipment is operates in a residential environment. This equipment generates, uses, and can radiate radio frequency energy and, if not installed and used in accordance with the instruction manual, may cause harmful interference to radio communications. However, there is no guarantee that interference will not occur in a particular installation. If this equipment does cause harmful interference to radio or television reception, which can be determined by turning the equipment off and on, the user is encouraged to try to correct the interference by one or more of the following measures:

- Reorient or relocate the receiving antenna.
- Increase the separation between the equipment and receiver.
- Connect the equipment into an outlet on a circuit different from that to which the receiver is connected.
- Consult the dealer or an experienced radio/TV technician for help.

If necessary, the user should consult the dealer or an experienced radio/television technician for additional suggestions. The user may find the following booklet prepared by the FCC helpful: "How to Identify and Resolve Radio Television Interference Problems". This booklet is available from the United States Government Printing Office, Washington, DC, 20402, Stock No. 004-000-00345-4.

DOC REQUIREMENTS

NOTICE: The Canadian Department of Communications label identifies certified equipment. This certification means that the equipment meets certain telecommunications network protective, operational, and safety requirements. The Department does not guarantee the equipment will operate to the user's satisfaction.

Before installing this equipment, users should ensure that it is permissible to be connected to the facilities of the local telecommunications company. The equipment must also be installed using an acceptable method of connection. In some cases, the company's inside wiring associated with a single line individual service may be extended by means of a certified connector assembly (telephone extension cord). The customer should be aware that compliance with the above conditions may not prevent degradation of service in some situations.

Repairs to certified equipment should be made by an authorized Canadian maintenance facility designated by the supplier. Any repairs or alterations made by the user to this equipment, or equipment malfunctions, may give the telecommunications company cause to request the user to disconnect the equipment.

Users should ensure for their own protection that the electrical ground connections of the power utility, telephone lines and internal metallic water pipe system, if present, are connected together. This precaution may be particularly important in rural areas.

Caution: Users should not attempt to make such connections themselves, but should contact the appropriate electric inspection authority, or electrician, as appropriate.

The Load Number (LN) assigned to each terminal device denotes the percentage of the total load to be connected to a telephone loop which is used by the device, to prevent overloading. The termination on a loop may consist of any combination of devices subject only to the requirement that the total of the Load Numbers of all the devices does not exceed 100. The Load Number for the Ovation system is 4.