

# The 820/860 Slide Gate Operator: Installation Manual

## Contents

Important Safety Information.....	2
Technical Data .....	4
Unpacking the Operator .....	5
The 820/860 Slide Gate Operator.....	6
General Characteristics .....	6
Operating Logic .....	7
Manual Release Mechanism.....	7
E1 (Semi-Automatic 1) Mode .....	8
E2 (Semi-Automatic 2) Mode .....	8
A1 (Automatic 1) Mode .....	8
A2 (Automatic 2) Mode .....	9
S1 (Security) Mode .....	9
S2 (Security Plus) Mode .....	9
B Mode.....	9
C Mode.....	9
Installation Instructions .....	11
Set the Forms for the Conduit and Concrete .....	11
Ground Mounting.....	11
Cantilevered Mounting.....	11
Mount the Operator on the Foundation Plate .....	11
Chain Operator .....	11
Rack and Pinion Operator .....	12
Connect the Electrical Power .....	14
Set the DIP Switches .....	15
Operating Logic.....	16
Pause Time .....	16
Warning Light Operation .....	17
Gate Orientation .....	17
Set the Limit Switches.....	17
Define the Midpoint.....	18
Set the Opened Limit.....	19
Set the Closed Limit.....	19
Relocating the Midpoint.....	19
Install Other Accessories.....	20
Remove the Bleed Screw .....	21
Adjust the Clutch of the Operator .....	22
Maintenance .....	23
Troubleshooting .....	24
Exploded View, 820/860 Mechanical Parts .....	25
Exploded View, 820/860 Electronic Parts .....	26

**FAAC International, Inc.**  
**303 Lexington Avenue**  
**Cheyenne, WY 82007**  
**www.faacusa.com**



# Important Safety Information

Both the installer and the owner and/or operator of this system need to read and understand this installation manual and the safety instructions supplied with other components of the gate system. This information should be retained by the owner and/or operator of the gate.

---

**WARNING!** To reduce the risk of injury or death

1. **READ AND FOLLOW ALL INSTRUCTIONS.**
  2. Never let children operate or play with gate controls. Keep the remote control away from children.
  3. Always keep people and objects away from the gate. **NO ONE SHOULD CROSS THE PATH OF THE MOVING GATE.**
  4. Test the gate operator monthly. The gate **MUST** reverse on contact with a rigid object or stop when an object activates the non-contact sensors. After adjusting the force or the limit of travel, retest the gate operator. Failure to adjust and retest the gate operator properly can increase the risk of injury or death.
  5. Use the emergency release only when the gate is not moving.
  6. **KEEP GATES PROPERLY MAINTAINED.** Read the owner's manual. Have a qualified service person make repairs to gate hardware.
  7. The entrance is for vehicles only. Pedestrians must use separate entrance.
  8. **SAVE THESE INSTRUCTIONS.**
- 

There are three kinds of safety issues involved with an automatic gate operator: issues arising from the design of the gate, from the installation of the gate and the operator, and from the use of the gate operator. The following information is designed to help you be sure

your gate and its operator are well-designed, installed correctly, and used safely.

## Gate Design

1. A gate is a potential traffic hazard, so it is important that you locate the gate far enough away from the road to eliminate the potential of traffic getting backed up. This distance is affected by the size of the gate, how often it is used, and how fast the gate operates.
2. The operator you choose to install on your gate must be designed for the type and size of your gate and for the frequency with which you use the operator.
3. Your gate must be properly installed and must work freely in both directions before the automatic operator is installed.
4. An automatic operator should be installed on the inside of the property/fence line. Do not install the operator on the public side of the property/fence line.
5. Pedestrians should not use a vehicular gate system. Prevent such inappropriate use by installing separate gates for pedestrians.
6. Exposed, reachable pinch points on a gate are potentially hazardous and must be eliminated or guarded.
7. Outward swinging gates with automatic operators should not open into a public area.
8. The operating controls for an automatic gate must be secured to prevent the unauthorized use of those controls.
9. The controls for an automatic gate should be located far enough from the gate so that a user cannot accidentally touch the gate when operating the controls.
10. An automatic gate operator should not be installed on a gate if people can reach or extend their arms or legs through the gate. Such gates should be guarded or screened to prevent such access.

## Installation

1. If you have any question about the safety of the gate operating system, do not install this operator. Consult the operator manufacturer.
2. The condition of the gate structure itself directly affects the reliability and safety of the gate operator.

3. Only qualified personnel should install this equipment. Failure to meet this requirement could cause severe injury and/or death, for which the manufacturer cannot be held responsible.
4. The installer must provide a main power switch that meets all applicable safety regulations.
5. Clearly indicate on the gate with a minimum of 2 warning signs (visible from either side of the gate) that indicate the following:
  - The gate is automatic and could move at any time, posing a serious risk of entrapment.
  - Children should not be allowed to operate the gate or play in the gate area.
  - The gate should be operated only when it is visible to the operator and the when the area is free of people and obstructions.
6. It is extremely unsafe to compensate for a damaged gate by overtightening a clutch or increasing hydraulic pressure.
7. Devices such as reversing edges and photocells must be installed to provide better protection for personal property and pedestrians. Install reversing devices that are appropriate to the gate design and gate application.
8. Before applying electrical power, be sure that the voltage requirements of the equipment correspond to your supply voltage. Refer to the label on your operator system.

**Use**

1. Use this equipment only in the capacity for which it was designed. Any use other than that stated should be considered improper and therefore dangerous.
2. When using any electrical equipment, observe some fundamental rules:
  - Do not touch the equipment with damp or humid hands or feet.
  - Do not install or operate the equipment with bare feet.
  - Do not allow small children or incapable persons to use the equipment.
3. If a gate system component malfunctions, turn off the main power before making any attempt to repair it.
4. Do not attempt to impede the movement of the gate. You may injure yourself as a result.
5. This equipment may reach high temperatures during operation; therefore, use caution when touching the external housing of the operator.
6. Learn to use the manual release mechanism according to the procedures found in this installation manual.
7. Before carrying out any cleaning or maintenance operations, disconnect the equipment from the electrical supply.
8. To guarantee the efficiency of this equipment, the manufacturer recommends that qualified personnel periodically check and maintain the equipment.

U.L. Class and FAAC Operator Model		Duty Cycle	Typical Use
<b>Class I: Residential Vehicular Gate Operator</b>			
402	746	Limited duty	<ul style="list-style-type: none"> <li>• Home use</li> <li>• Small apartment building, for example, up to 4 units in a building, with limited public access</li> </ul>
422	750		
412	760		
630			
<b>Class II: Commercial/General Access Vehicular Gate Operator</b>			
400	640	Continuous duty	<ul style="list-style-type: none"> <li>• Apartment buildings</li> <li>• Very public access</li> </ul>
620			
<b>Class III: Industrial/Limited Access Vehicular Gate Operator</b>			
400	640	Continuous duty	<ul style="list-style-type: none"> <li>• No public access</li> </ul>
620			
<b>Class IV: Restricted Access Vehicular Gate Operator</b>			
620	640	Continuous duty	<ul style="list-style-type: none"> <li>• Prison rated security</li> </ul>

## Technical Data

Parameter	820	860
Maximum motor run time at 72 deg F (24 deg C)	30%	
Maximum gate leaf length		
Z16 gear, ft (m)	33 (10)	33 (10)
Z20 gear, ft (m)	42 (13)	42 (13)
Z28 gear, ft (m)	59 (18)	59 (18)
Pulling force <sup>b</sup> : At start up under maximum load		
Z16 gear, lb (kg)	45 (21)	85 (38)
Z20 gear, lb (kg)	35 (16)	65 (30)
Z28 gear, lb (kg)	25 (11)	45 (21)
Speed		
Z16 gear, in./sec (cm/sec)	8 (20)	8 (20)
Z20 gear, in./sec (cm/sec)	10 (25)	10 (25)
Z28 gear, in./sec (cm/sec)	14 (35)	14 (35)
A/C (partial open) distance		
Z16 gear, ft (m)	4 2/3 (1.4)	4 2/3 (1.4)
Z20 gear, ft (m)	5 1/4 (1.6)	5 1/4 (1.6)
Z28 gear, ft (m)	6 2/3 (2)	6 2/3 (2)
Drives available	Chain or rack and pinion	
Horsepower, hp	1/2	3/4
Power voltage required, VAC (60 Hz) <sup>c</sup>	230 +6 or -10% <sup>c</sup>	
Operator dimensions, l × w × h, in. (cm)	9 1/4 × 5 1/2 × 15 (23.5 × 14 × 38.2)	9 1/4 × 5 1/2 × 15 3/4 (23.5 × 14 × 40.2)
Operator weight, lb (kg)	31 (14)	34 (15)
Oil type	FAAC XD 220 or Shell/Tellus #15	
Oil quantity, qt (l)	1 (0.9)	

<sup>a</sup> Motor run time may vary if gate and operator are not installed properly.

<sup>b</sup> Measured at 220 volts and at 72 deg F (22 deg C). Increased or decreased voltage affects pulling forces respectively.

<sup>c</sup> Your standard 220 VAC power source meets the specification for 230 VAC, +6 or -10%.

# Unpacking the Operator

When you receive your 820 or 860 Operator (see Figure 1), complete the following steps.

Inspect the shipping box for physical damage such as leaking oil or a torn carton. Then inspect the operator after you remove it from the box. Notify the carrier immediately if you note any damage because the carrier must witness the damage before you can file a claim.

As you unpack the box, insure that all the parts listed are included.

Operator carton

- 1 Operator included with customer-ordered chain drive or rack and pinion drive
- 1 Shrink wrapped package with the following:
  - 2 Mounting washers
  - 4 Leveling bolts
  - 4 Nuts for leveling bolts
  - 2 Larger nuts for mounting bolts
  - 1 Manual Release Lever

(a) Chain drive

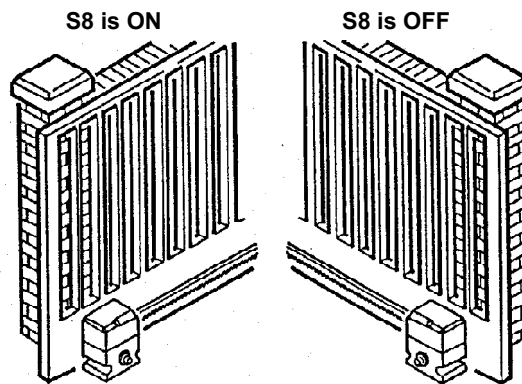


Figure 1. Dimensions of the 820/860 operators

# The 820/860 Slide Gate Operator

## General Characteristics

The 820 and 860 Slide Gate Operators are compact operators with *GentleSlide*<sup>™</sup> Motion Management for high-traffic applications. The 820 is designed for medium-weight gates, and the 860 is designed for heavier gates. Either operator is available with a chain drive or a rack and pinion drive.

Both operators feature internal limit switches for gate leaves up to 59 ft (18 m) in length. (The 860 can also accept external limit switches for gates as long as 66 ft [20 m].) The operators also feature internal cooling systems, interchangeable gears for various sized gates and gate speeds, and a partial opening function.

The new partial opening function allows you to open the gate just enough for motorcycle traffic, for example, without compromising your security.

Each operator has a die-cast anodized aluminum housing and a die-cast aluminum cover protected by

polyester paint. Those mechanical components requiring extra strength are made of steel or cast iron.

The motor for the 820 or 860 Operator serves as a gate lock. For further reliability, the motor's armature shaft is mounted on double bearings. The worm drive mechanism and single-plate clutch are encased in oil to lubricate their moving parts and dissipate the heat they generate during operation.

Inside the operator's housing you will find that the transformer, capacitor, and analog-digital limit switch module are separate from the main control panel board for easy maintenance (see Figure 2). In addition, the control panel provides quick-connector ports.

The 826 MPS control panel inside the 820 or 860 Operator offers you choices in gate leaf functions. For example, you can choose among eight different logical modes of operation. You can also select the pause time you want (from 5 to 180 sec, depending on logic mode), the direction in which the gate slides, and the operation

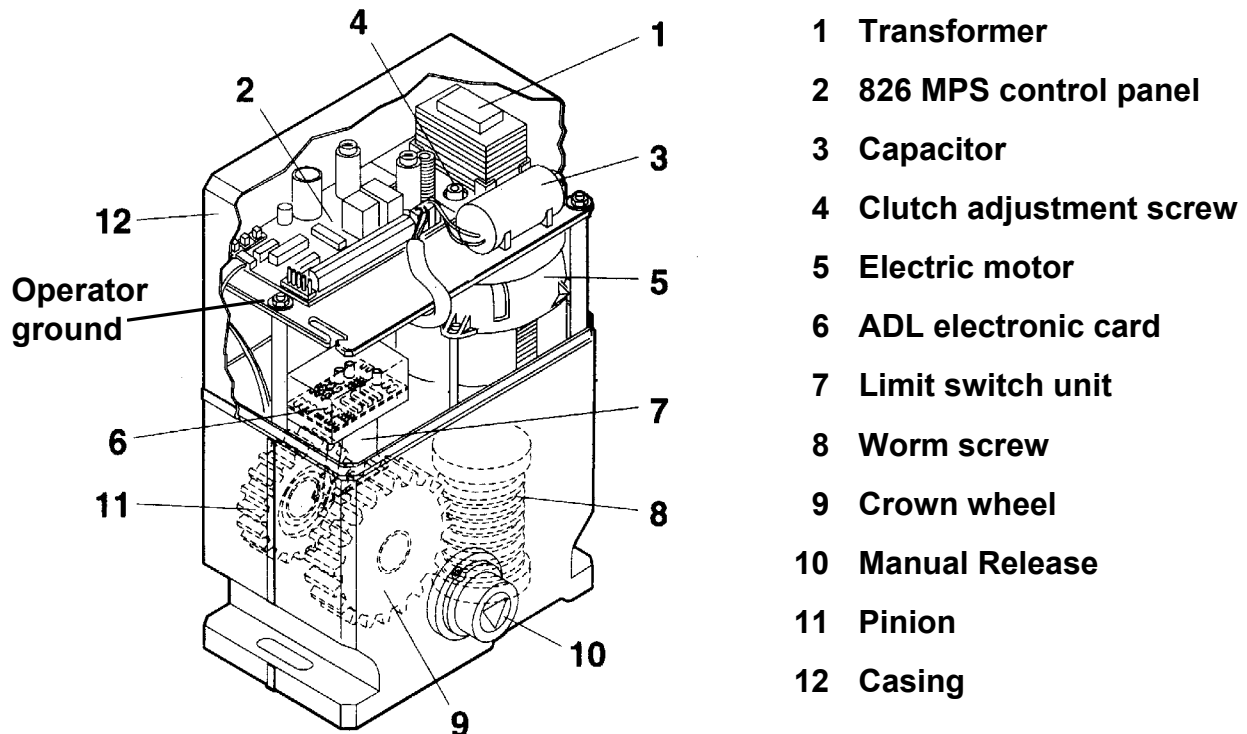


Figure 2. The 820 or 860 Operator with the cover removed

of the warning light as the gate leaf closes. The control panel also accepts a wide range of product accessories and reversing devices to allow you the maximum flexibility in designing your gate system.

One feature of FAAC's slide gate operators is the adjustable internal limit switch function. By setting the operator to recognize the fully closed and fully opened positions of the gate leaf's travel, you also enable the operator to automatically brake the gate leaf before it reaches the end of its travel in either direction, thus causing less stress on your gate leaf.

Safety features on the 820 or 860 Operator include an adjustable, oil-immersed clutch that is designed to help provide anti-crush protection for both pedestrians and property, as well as for the gate system itself. The location of the clutch—on the input side of the gear box—allows for sensitive control of sliding pressures.

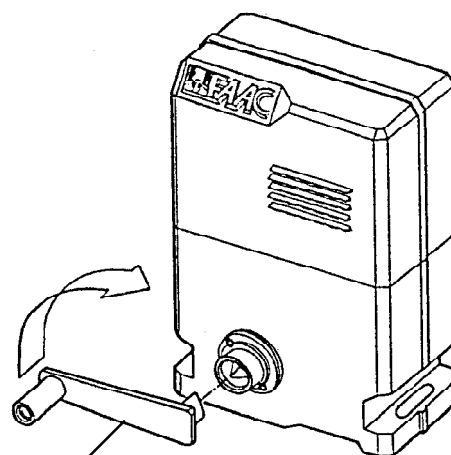
**WARNING!** The anti-crush clutch adjustment should not be considered adequate protection for pedestrians or property! Additional reversing accessories, such as inductive loops, photocells, or reversing edges, must be installed for more complete pedestrian and property safety.

With the clutch pressure properly adjusted, the 820 Operator or the 860 Operator with the Reverse on Contact function (RC) automatically re-opens the gate if an obstacle blocks the gate's closing. During opening, an encountered obstacle causes the gate to stop its motion.

**WARNING!** When encountering an obstacle, the 860 without the reverse on contact (RC) function does not reverse during closing nor does it stop on opening. To provide comparable safety, you must use additional reversing devices and you must adjust the operator's clutch with great care.

A Manual Release mechanism is also provided on both the 820 and 860 (see Fig. 3). This lever operated mechanism can be used to disengage the drive motor so that you can open or close the gate leaf by hand. Such manual operation of the gate is necessary during installation and may be useful in power failures and emergencies.

Also, on the chain-drive version of either the 820 or 860, a chain guard is provided to fit around the sprockets and prevent foreign objects from being caught between the chain and sprocket. On the rack and pinion version, a pinion guard is provided for comparable safety.



Manual Release Lever:  
turn clockwise to  
disengage the motor

**Figure 3. The Manual Release Lever on the 820 and 860 Operators**

## Operating Logic

The 820 and 860 Operators provide a Manual Release mechanism for manually operating the gate as well as eight different operating logics (also see page 10).

## Manual Release Mechanism

The Manual Release mechanism is a built-in emergency release device of the 820/860 Operators (see Figure 3). You disengage the operation of the operator by rotating the Manual Release Lever in a clockwise direction. Then you can move the gate by hand to open or close the gate.

Operating the gate by hand is necessary during installation and is useful during power failures and other emergencies.

After such an emergency, you re-engage the drive of the operator by rotating the Manual Release Lever counterclockwise.

**Caution:** After you re-engage the drive with the Manual Release Lever and *before* you signal the operator, manually slide the gate leaf in either direction until the gear is properly aligned and locked. (You may hear it lock into position.) This helps to protect the drive gear of your operator.

## E1 (Semi-Automatic 1) Mode

The E1 (semi-automatic 1) mode of operation for the 820/860 Operator is designed for users who want to signal the gate to either open or close. Sending one signal, either *open* or *A/C*, to the gate causes it to open and remain open until another signal is sent. Sending a second signal closes the gate.

The basic logic of E1 mode is enhanced to protect both people and property if anything interrupts the gate's movement. What happens after such an interruption depends on whether the gate is opening or closing when the interruption occurs and depends on whether the interruption is a second signal or an obstacle in the gate's path.

When a second signal interrupts the gate's opening, the gate stops. The gate does not move until yet another signal is sent. Then the gate closes. If a signal interrupts the gate during closing, the gate immediately reopens.

If an operator has the RC function and an obstruction interrupts the gate's opening, the gate may stop its movement (depending on the weight of the obstruction and the adjustment of the clutch). When you send a signal after the gate stops and after the obstruction is removed, the gate closes.

**WARNING!** The pressure the gate leaf applies to the obstruction is determined by the clutch adjustment. It is the installer's responsibility to make sure the clutch is correctly set.

**WARNING!** An 860 without RC continues to open against an obstacle. You must install reversing devices to protect any potential obstacle against the momentum and weight of the gate during opening.

If an operator has the RC function and an obstacle interrupts the gate's closing, the gate stops its movement and automatically re-opens. Sending another signal causes the gate to close.

**WARNING!** An 860 without RC continues to close against an obstacle. You must install reversing devices to protect any potential obstacle against the momentum and weight of the gate during closing.

Installing external reversing devices alters the logic of E1 mode operation in the following way: During the opening cycle, any triggered reversing device is ignored, that is, the gate continues its opening movement. During closing, a triggered reversing device causes the gate to fully re-open. Another signal is then necessary to close the gate.

## E2 (Semi-Automatic 2) Mode

The E2 (semi-automatic 2) mode of operation is like E1 except in the way the gate leaf responds while closing with reversing devices installed.

In E2 mode, a triggered reversing device while the leaf is closing causes the leaf to stop. It remains stopped until the reversing device is no longer triggered, and then the leaf opens.

## A1 (Automatic 1) Mode

The A1 (automatic 1) mode of operation for the 820/860 Operator is designed for users who want to signal the gate once to open (with an *A/C* or *open* command) and then automatically close after a selected time.

What happens when A1 mode operation is interrupted depends on which part of the cycle is interrupted by an activating signal or obstruction. During the opening phase, a second signal is ignored; the gate continues its opening travel. During the pause phase, a signal resets the pause count to 3 or 5 seconds, depending on the warning light logic. During the closing phase, a signal to the gate causes the gate to reopen immediately.

If an obstacle interrupts A1 mode operation during opening on an operator with the RC function, the gate stops its movement. When it receives another signal after the obstacle is removed, the gate then will continue to open.

**WARNING!** An 860 without RC continues to open against an obstacle. You must install reversing devices to protect any potential obstacle against the momentum and weight of the gate during opening.

If during closing an obstacle interrupts A1 mode operation on an operator with the RC function, the gate stops its movement and automatically re-opens. Sending another signal to the gate causes it to complete another open-pause-close cycle.

**WARNING!** An 860 without RC continues to close against an obstacle. You must install reversing devices to protect any potential obstacle against the momentum and weight of the gate during closing.



Installing reversing devices has the following effects on the logic of A1 mode: During the opening phase, a triggered reversing device is ignored; the gate continues to open. During the pause phase, a triggered reversing device stops the count of the pause phase. The pause count resumes when the reversing device is no longer triggered. During the closing phase, a triggered reversing device causes the gate to immediately reopen.

**WARNING!** For maximum safety to people and property when you use A1 mode, use a non-contact (loop detector or photocell) reversing device.

## A2 (Automatic 2) Mode

The A2 (automatic 2) operating logic is like A1 mode except in the way a gate leaf responds to triggered reversing devices when the leaf is fully opened and when the leaf is closing.

During the pause phase the leaf will close after a 5-sec delay once the reversing device is no longer triggered.

When the leaf is closing, a triggered reversing device causes the leaf to stop. When the reversing device is no longer triggered, the leaf opens.

**WARNING!** For maximum safety to people and property when you use A2 mode, use a non-contact (loop detector or photocell) reversing device.

## S1 (Security) Mode

The S1 (security) mode of operation is similar to the A1 mode with the following exception: If an activating signal is sent while the gate is in its opening or pause phases, the gate closes immediately.

**WARNING!** For maximum safety to people and property when you use S1 mode, use a non-contact (loop detector or photocell) reversing device.

## S2 (Security Plus) Mode

The S2 (security plus) mode of operation is similar to S1 mode except in the way reversing devices operate.

During the pause phase of S2 logic, a triggered reversing device interrupts the pause count but does not reset the pause count. The gate continues its pause phase after the reversing device is no longer triggered, and the gate then closes when the count has finished.

During the closing phase of S2 logic, a triggered reversing device stops the gate. When the reversing device is no longer triggered, the gate reopens.

**WARNING!** For maximum safety to people and property when you use S2 mode, use a non-contact (loop detector or photocell) reversing device.

## B Mode

The B mode of operation is designed for a gate system that is attended by a person who accesses a three-button switch to open, close, or stop the gate leaf.

Essentially, in B mode you must press the switch for the movement you desire. For example, if you want the gate to open, you must press the *open* button on the switch. The exception to the "you get what you press" logic is that you must always stop the gate while it is in motion if you want to change the direction of the gate's travel before the gate reaches its limit.

**Note:** The A/C signal functions as a close signal in the B mode.

Any installed reversing devices will work only during the closing phase of the gate's movement. Reversing devices will have no effect during the opening of the gate.

## C Mode

The C mode of operation requires a person to attend a two-button (at least) switch to open and close the gate.

In C mode, the gate leaf moves only while the activating button is being pressed. Thus, the attendant must press the activating button for as long as is necessary for the gate leaf to fully open or fully close.

**Note:** The A/C signal functions as a close signal in the C mode.

If a three-button switch is used with C mode, the stop button will stop the gate whenever it is pressed. Any reversing devices installed will work only during the closing phase of the gate's movement.

### E1 Logic: How the gate leaf behaves

Leaf status	Signal		
	Open or A/C <sup>1</sup>	Stop	Reversing
Closed	Opens	no effect	no effect
Open	Closes	no effect	no effect
Closing	Opens	Stops	Opens
Opening	Stops	Stops	no effect
Stopped	Closes <sup>2</sup>	no effect	no effect

<sup>1</sup>An A/C signal causes the leaf to partially open.

<sup>2</sup>The leaf opens if reversing devices are triggered.

### E2 Logic: How the gate leaf behaves

Leaf status	Signal		
	Open or A/C <sup>1</sup>	Stop	Reversing
Closed	Opens	no effect	no effect
Open	Closes	no effect	no effect
Closing	Opens	Stops	Stops. Opens when reversing device no longer triggered
Opening	Stops	Stops	no effect
Stopped	Closes <sup>2</sup>	no effect	no effect

<sup>1</sup> An A/C signal causes the leaf to partially open.

<sup>2</sup> Leaf opens if reversing devices are triggered.

### A1 Logic: How the gate leaf behaves

Leaf status	Signal		
	Open or A/C <sup>1</sup>	Stop	Reversing
Closed	Opens, pauses, and closes	no effect	no effect
Open	Resets pause count, pauses, and closes	Stops pause count	Freezes the pause count until reversing device no longer triggered
Closing	Opens	Stops	Opens
Opening	no effect	Stops	no effect
Stopped	Closes	no effect	no effect

<sup>1</sup> An A/C signal causes the leaf to partially open.

### A2 Logic: How the gate leaf behaves

Leaf status	Signal		
	Open or A/C <sup>1</sup>	Stop	Reversing
Closed	Opens, pauses, and closes	no effect	no effect
Open	Closes	Stops pause count	Closes after 5 sec when reversing device no longer triggered
Closing	Opens	Stops	Stops. Opens when reversing device no longer triggered
Opening	no effect	Stops	no effect
Stopped	Closes	no effect	no effect

<sup>1</sup> An A/C signal causes the leaf to partially open.

### S1 Logic: How the gate leaf behaves

Leaf status	Signal		
	Open or A/C <sup>1</sup>	Stop	Reversing
Closed	Opens, pauses, and closes	no effect	no effect
Open	Closes	Stops pause count	Closes after 5 sec when reversing device no longer triggered
Closing	Opens	Stops	Stops. Opens when reversing device no longer triggered
Opening	Closes	Stops	no effect
Stopped	Closes	no effect	no effect

<sup>1</sup> An A/C signal causes partial opening.

### S2 Logic: How the gate leaf behaves

Leaf status	Signal		
	Open or A/C <sup>1</sup>	Stop	Reversing
Closed	Opens, pauses, and closes	no effect	no effect
Open	Closes	Stops pause count	Freezes the pause count until reversing device is no longer triggered
Closing	Opens	Stops	Stops. Opens when reversing device no longer triggered
Opening	Closes	Stops	no effect
Stopped	Closes	no effect	no effect

<sup>1</sup> An A/C signal causes partial opening.

### B Logic: How the gate leaf behaves

Leaf status	Signal			
	Open	A/C <sup>1</sup>	Stop	Reversing
Closed	Opens	no effect	no effect	no effect
Open	no effect	Closes	no effect	no effect
Closing	no effect	no effect	Stops	Stops
Opening	no effect	no effect	Stops	no effect
Stopped	Opens	Closes	no effect	no effect

<sup>1</sup> An A/C signal functions as a close signal in B logic.

### C Logic<sup>1</sup>: How the gate leaf behaves

Leaf status	Signal			
	Open	A/C <sup>2</sup>	Stop	Reversing
Closed	Opens	no effect	no effect	no effect
Open	no effect	Closes	no effect	no effect
Closing	no effect	Closes	Stops	Stops
Opening	Opens	no effect	Stops	no effect
Stopped	Opens	Closes	no effect	no effect

<sup>1</sup> The leaf moves only while a switch button is pressed.

<sup>2</sup> An A/C signal functions as a close signal in C logic.

# Installation Instructions

**Note:** The following installation instructions assume you are fully capable of installing an electronic operator for a gate. This manual does not instruct you in designing a gate, installing a gate (whether on masonry, wood, or metal posts), or basic electrical wiring. The installation tasks discussed in this manual are tasks peculiar to the 820/860 Operator.

Before you install the 820 or 860 Operator, you must insure that the gate leaf falls within the limitations outlined in the section "Technical Data." Installing the 820 or 860 Slide Gate Operator consists of the following steps:

- Setting the forms for the conduit and concrete
- Mounting the operator on the foundation plate
- Connecting electrical power
- Setting DIP switches
- Setting the limit switches
- Installing other accessories
- Removing the bleed screw
- Adjusting the clutch of the operator

## Set the Forms for the Conduit and Concrete

### Ground Mounting

You need to set the concrete forms for the footing a minimum of 18 in. (46 cm) below the ground level or just below the frost line, whichever is greater (see Figure 4). (Your soil type conditions will also determine the size of the cement footing.)

Within the form boundaries, you must locate the electrical conduit so that it protrudes through the foundation plate and above the top of the foundation plate about 1/2 in. (1.3 cm).

If you choose to supply your own foundation plate, be sure to use steel that is at least 1/8 in. (0.3 cm) thick and be sure your conduit hole is large enough to accommodate two conduits, one for high voltage and one for low voltage. In addition, your foundation plate must be anchored with bolts that extend at least 3 5/8 in. (9.2 cm) into the cement. Note that the optionally available FAAC foundation plate has steel legs 3 5/8 in. (9.2 cm) long that bend to a vertical position instead of cement footing anchor bolts (see Figure 5).

After the concrete is poured in the forms and before it sets, place the foundation plate in the cement so that the top of the plate is level and flush with the top of the

cement. Make sure the electrical conduit protrudes above the foundation plate and cement.

Allow the concrete to set a minimum of two full days before you mount the operator.

### Cantilevered Mounting

For a cantilevered gate installation in which you supply your own mounting plate and pedestal, keep the following in mind:

Use a minimum of 3/16 in. steel for your plate and a 4 × 4 in. square (to prevent rotation) tube for your pedestal. The mounting plate must accommodate two electrical conduits, one for high voltage and one for low voltage.

Encase a minimum of 18 in. of the height of your pedestal in a cement footing that is at least 16 × 12 × 18 in. (Your soil conditions will also determine the size of the cement footing.)

Within the form boundaries for your cement footing, you must locate the electrical conduits so that they protrude up through the pedestal and above the mounting plate about 1/2 in. (1.3 cm).

Allow the concrete to set a minimum of two full days before you mount the operator.

## Mount the Operator on the Foundation Plate

Follow the instructions below that apply to the version of the operator you are installing.

### Chain Operator

First, attach the nuts to the leveling bolts. Then slip the leveling bolt nuts into the hexagonal holes in the four corners on the bottom of the operator.

As shown in Figures 4 and 6, place the operator on the foundation plate with the sprocket facing the gate with approximately 15/16 in. (2.4 cm) between the inside edge of the gate frame (where you mount the chain bracket) and the center of the drive sprocket.

Secure the gate chain brackets to the vertical front and back posts of the gate leaf using the U bolts provided. Set the height of the gate chain brackets so that the centers of the idler sprockets located on either side of the drive sprocket are slightly higher than the center line of the brackets. This alignment compensates for any sag in the chain. You can now install the mounting bolts to secure the operator to the foundation plate.

Place the chain over the top of the idler sprockets and under the drive sprocket (see Figure 7).

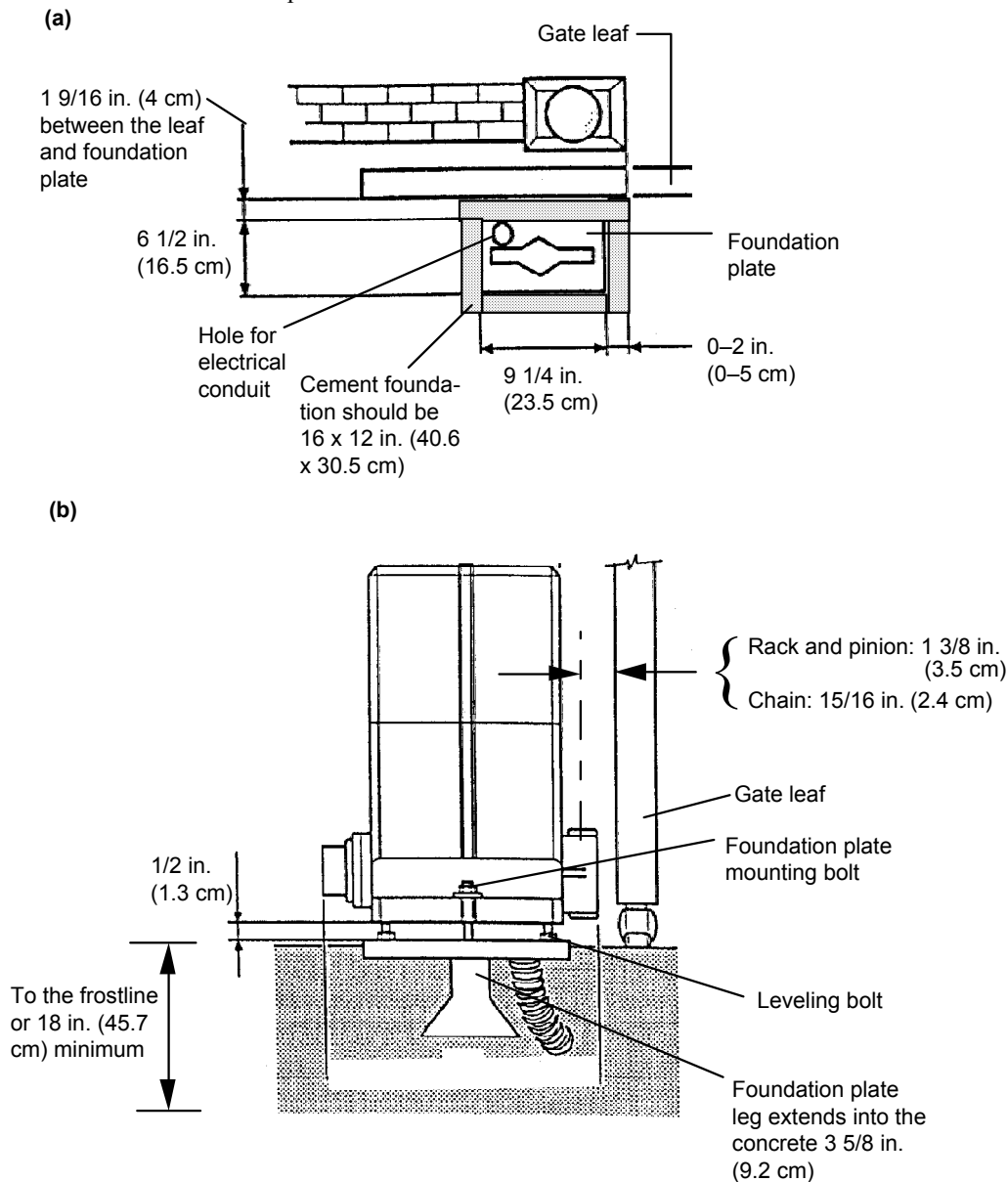
## Rack and Pinion Operator

First, attach the nuts to the leveling bolts. Then slip the leveling bolt nuts into the hexagonal holes in the four corners on the bottom of the operator.

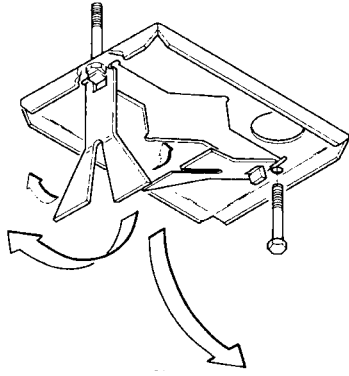
As shown in Figure 4, place the operator on the foundation plate with the pinion facing the gate with approximately 1 3/8 in. (3.5 cm) between the inside edge of the gate frame (where you mount the rack spacers) and the center of the drive pinion.

Next you need to set the height for the rack by adjusting the leveling bolts. Raise the operator with the leveling bolts at least enough so that you will later be able to lower the operator 1/16 in. (1.5 mm) (this is the clearance you need for the rack to move over the pinion). Now you can secure the operator to the foundation plate with the mounting bolts.

Prepare the rack sections by installing the spacers, washers and bolts on the rack sections as shown in Figure 8. The bolts should be centered in the slots of the rack sections.

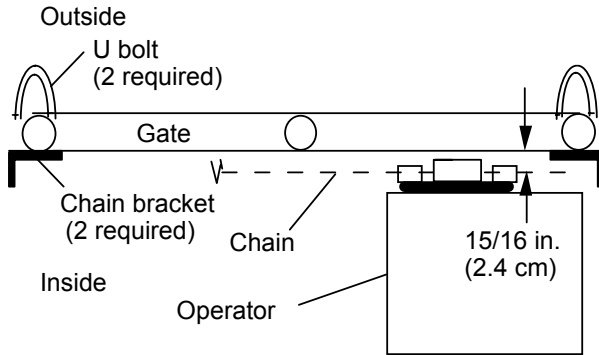


**Figure 4. The concrete footing and 820/860 Operator in relation to the gate leaf:  
(a) top view and (b) side view**

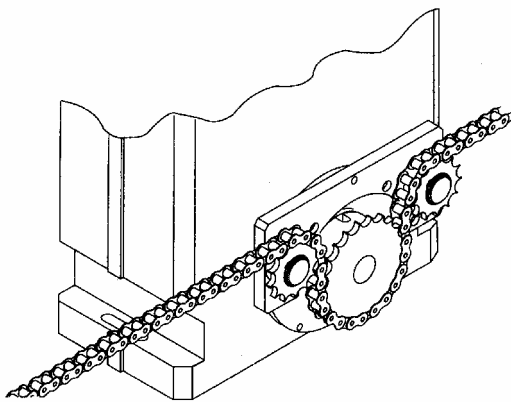


1. Insert the anchor bolts for the operator up through the foundation plate
2. Bend the legs down so they are vertical.
3. Bend the feet on the legs to a horizontal orientation.

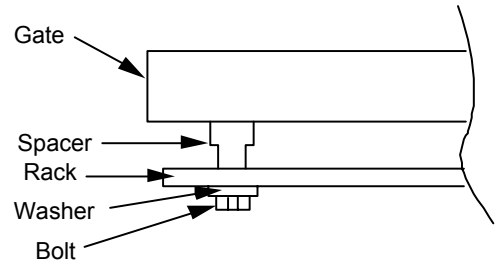
**Figure 5. Preparing the optional FAAC foundation plate**



**Figure 6. Dimensions for installing the chain, top view**

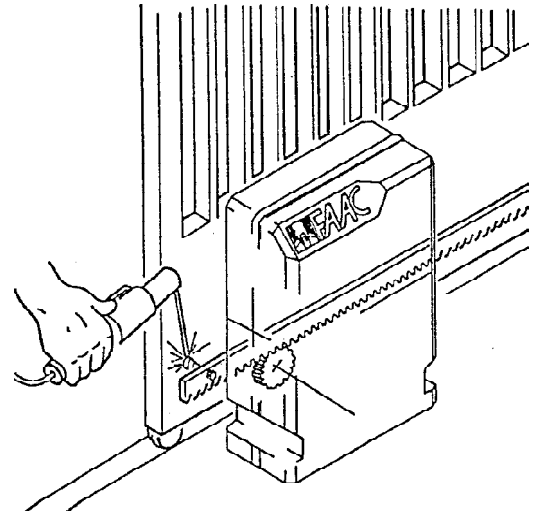


**Figure 7. How to install the chain around the sprockets**

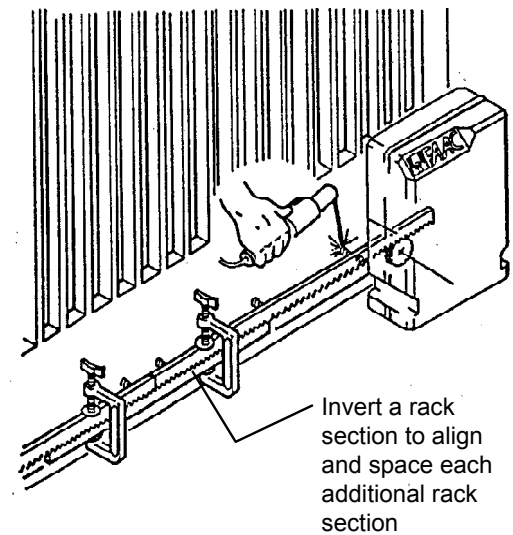


**Figure 8. Placement of spacer, washer, and bolt**

**(a) Welding a rack spacer to the gate leaf**



**(b) Note use of inverted rack section**



**Figure 9. Welding rack sections**

To mount the rack, slide the gate leaf open as far as it will go. Then use the Manual Release lever to disengage the operator's drive motor (turn the lever clockwise; see Figure 2).

Lay a prepared section of rack on the pinion making sure of the following:

- The teeth of the rack are properly engaged.
- The end of the rack is even with the end of the gate leaf.
- The rack is level.

Spot weld the spacer nearest the pinion to the gate leaf (see Figure 9). Then pull the gate leaf toward the closed position until the pinion is directly under the spacer on the opposite end of the rack section and spot weld that spacer.

After spot welding both end-of-rack spacers to the gate leaf, you can spot weld the center spacer to the gate leaf.

For the next rack section, place its end next to the end of the previously installed section. Use an inverted section of rack to properly align and space the next rack section. Again be sure that the teeth of the rack are properly engaged, that the two sections of rack are aligned, and that the rack section is level.

Spot weld the new section of rack to the gate leaf, welding the end closest to the previously welded section

first, the other end of the rack second, and the center last. Spot weld all sections of rack in the same manner. After spot welding the rack to the gate leaf, you need to move the gate from the fully closed to the fully opened position several times to make sure the rack moves smoothly along the pinion. If it moves smoothly, finish welding the spacers to the gate.

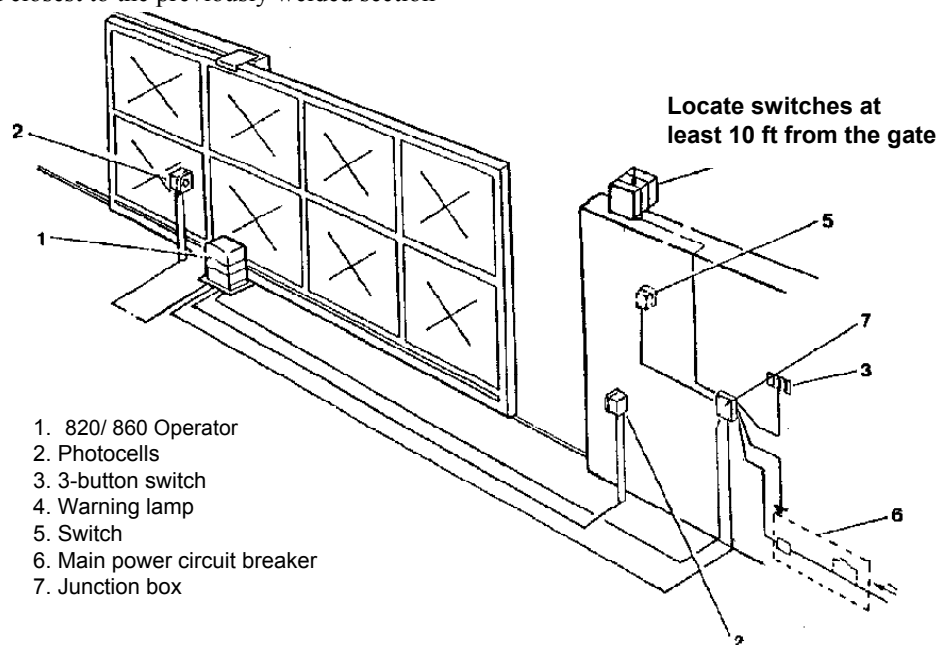
Finally, lower the operator about 1/16 in. (1.5 mm) and again test the operation of the rack while the gate moves from the fully opened to the fully closed position.

## Connect the Electrical Power

**Note:** Be sure to ground the operator system and protect the entire gate system with a main power breaker switch. Refer to your local electrical codes and ensure they are met when you select these components.

The installer is responsible for providing a power cable with ground protected by a circuit breaker from the main 220 VAC power source to the operator.

All wiring should conform to applicable electrical codes and all wiring and fittings should be weatherproof and/or suitable for burial. Figure 10 shows a typical gate



**Figure 10. Typical gate system layout for an 820 or 860 Operator**

system using the 820 or 860 Operator; the figure also lists the required wire gauges between gate components. Figure 11 shows the wiring necessary between the operator and the main power source.

To connect the power source to the operator in a non-pedestal, non U.L. Listed configuration, first remove the cover of the operator. Be sure the main power source is turned off, and connect the main power to terminals 13 and 14 on the control panel (see Figure 12). Connect the ground wire from the main power source to the operator ground (see Figure 2).

## Set the DIP Switches

**WARNING!** Turn the main power off before you make any electrical connections or set any switches on the control panel.

Eight DIP switches on the control panel control the following:

- The operating logic of the operator
- The pause time of the gate leaf between opening and closing
- The operation of an installed warning light
- The gate orientation, the direction of the gate leaf's travel in closing

To access the DIP switches, turn the main power off and remove the cover of the operator (remove the screw in the center of each side). Then remove the plastic cover over the control panel.

If you set the DIP switches while the main power to the operator is off, turning the power on resets the control panel to the settings you have made. If you set any DIP switches while the main power is on, then you must press the RESET button for the control panel to accept your settings. The directions for setting the DIP switches follow.

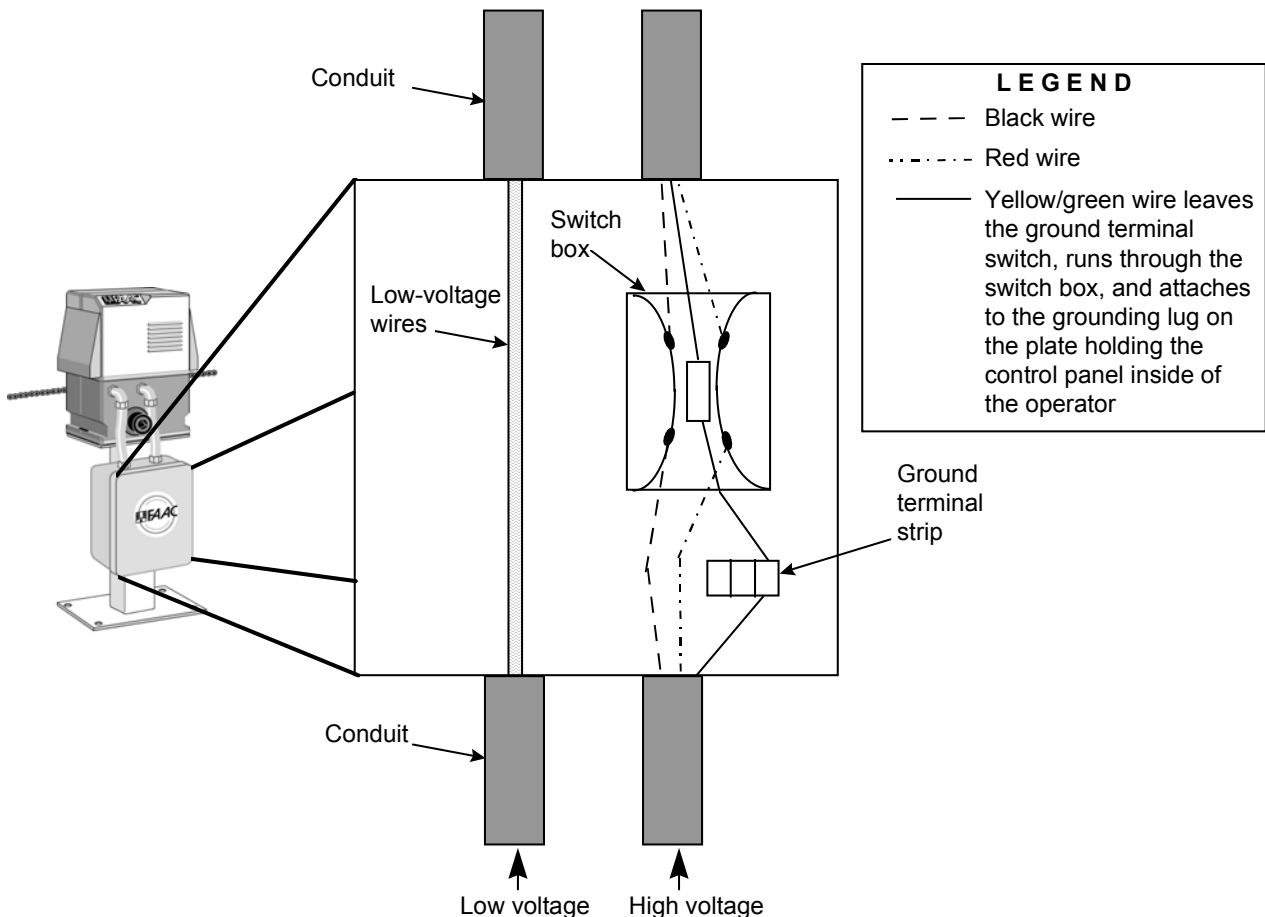
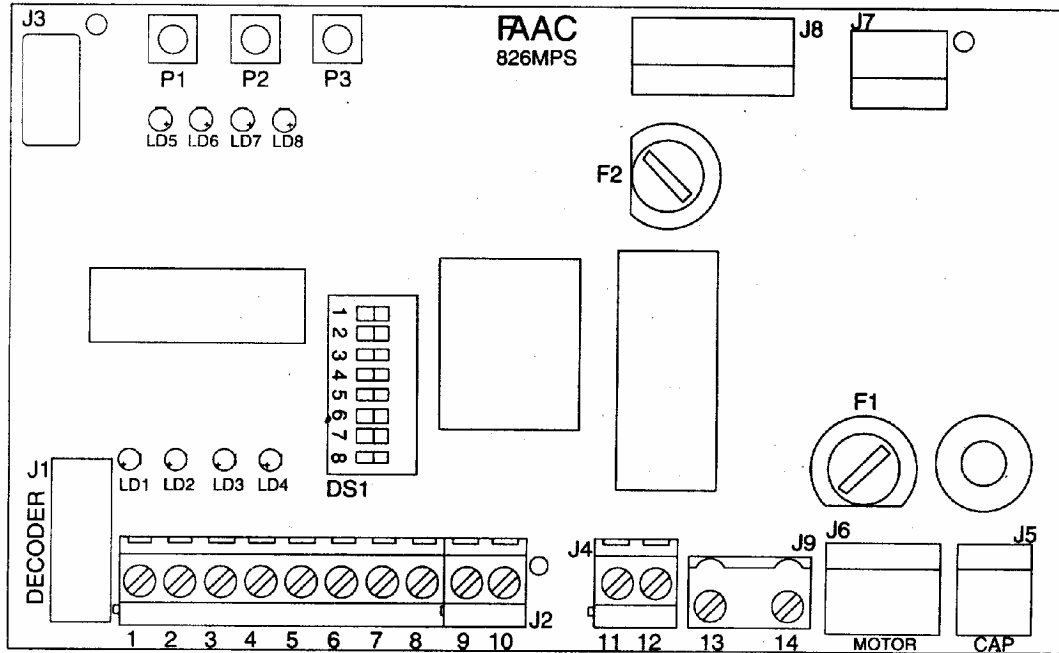


Figure 11. Required wiring between the operator and the main power supply



- |            |                                 |            |   |
|------------|---------------------------------|------------|---|
| <b>J1</b>  | Decoder connector               | <b>LD1</b> | (OPEN) Open LED                         |
| <b>J2</b>  | Low-voltage terminal Block      | <b>LD2</b> | (A/C) Partial open/close LED            |
| <b>J3</b>  | ADL connector                   | <b>LD3</b> | (STOP) Stop LED                         |
| <b>J4</b>  | FAAC lamp output terminal block | <b>LD4</b> | (FTSW) Safety LED                       |
| <b>J5</b>  | Capacitor connector             | <b>LD5</b> | (ADL) Limit switch alarm LED            |
| <b>J6</b>  | Electric motor connector        | <b>LD6</b> | (FCA) Opening limit switch LED          |
| <b>J7</b>  | Transformer primary connector   | <b>LD7</b> | (FCC) Closing limit switch LED          |
| <b>J8</b>  | Transformer secondary connector | <b>LD8</b> | (S) Power LED                           |
| <b>J9</b>  | High-voltage terminal block     | <b>P1</b>  | Opening limit switch programming button |
| <b>F1</b>  | Motor fuse F1, 5 amps,          | <b>P2</b>  | Closing limit switch programming button |
| <b>F2</b>  | Accessory fuse F2, 1.6 amps     | <b>P3</b>  | Limit switch/reset programming button   |
| <b>DS1</b> | DIP switch assembly             |            |   |

Figure 12. The layout of the 826 MPS control panel

## Operating Logic

Switches S1, S2, and S3 allow you to set the operating logic of the gate operator (see the section "Operating Logic" for a complete discussion of the logical operating modes). Use the table below to set the three switches.

Logic	S1	S2	S3
E1	On	On	On
E2	On	Off	Off
A1	Off	On	On
A2	Off	Off	Off
S1	Off	Off	On
S2	On	Off	On
B	On	On	Off
C	Off	On	Off

## Pause Time

Switches S4 and S5 allow you to set the pause time between opening and closing for those logical operating modes that have a pause time defined by the operator. Use the table below to set your S4 and S5 switches.

**Note:** The warning light is on during the last 5 sec of the pause time according to the setting of switch S6.

Switch		Pause Time, sec	
S4	S5	A1, A2, or S2 Logic:	S1 Logic:
On	On	5	15
Off	On	10	30
On	Off	30	60
Off	Off	120	180



## Warning Light Operation

The function of a warning light depends on how you connect the light to the 826 MPS terminal strip and how you set DIP switches S6 and S7. Use the following tables at the bottom of the page to decide how to set up your warning light.

**Caution:** Setting switch S7 to *on* delays the opening response of the gate by 5 sec in *all* logical operating modes and delays the closing response in E1 and E2 for 5 sec while the warning light behaves according to the setting of switch S6 for closing.

## Gate Orientation

**Caution:** If you have already defined the gate's midpoint or set the limit switches and if you want to change the gate orientation, set switch S8 *only when the ADL light (LED LD5) is illuminated.*

**Note:** Changing the setting of DIP switch S8 after you have set the limit switches *requires* you to set the limit switches again.

Switch S8 is used to set the gate's orientation. You must set switch S8 before you set the limit switches for fully opened and fully closed positions of the gate leaf.

While standing on the same side of the gate leaf as the operator is located (see Figure 13), determine whether the gate leaf moves to the left or right when closing and set the switch according to Figure 13.

## Set the Limit Switches

**WARNING!** Setting the limit switches requires the main power to the operator to be on while you work with the control panel. Do not touch other parts of the operator with the main power on. Observe standard rules of electrical safety while setting the limit switches.

**Caution:** Take great care in setting the limit switches, in particular the midpoint of the gate leaf's travel. Failure to properly set the limit switches can result in mechanical failure of the limit switch module or can make the gate leaf incapable of fully opening or fully closing.

**Warning Light Wired to Terminals 8 and 9**

Switches		Behavior of Warning Light According to Gate Leaf Status				
S6	S7	closed	5-sec before opening	opened or opening	5 sec before closing	closing
on	off	off	on	on	on	on
on	on	off	on	on	on	on
off	off	off	on	on	on	flashes
off	on	off	on	on	flashes	flashes

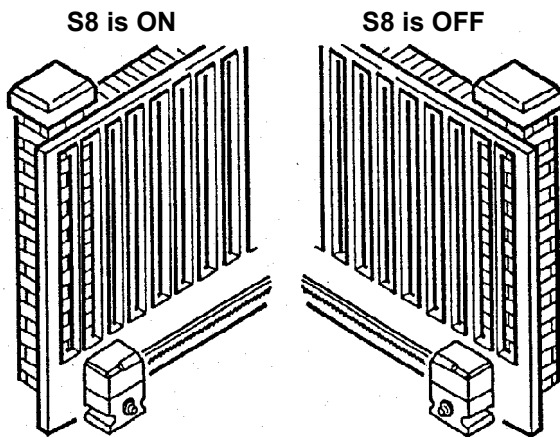
**Warning Light Wired to Terminals 8 and 10**

Switches		Behavior of Warning Light According to Gate Leaf Status				
S6	S7	closed	5-sec before opening	opened or opening	5 sec before closing	closing
on	off	on	on	off	off	off
on	on	on	off	off	off	off
off	off	on	on	off	off	flashes
off	on	on	off	off	flashes	flashes

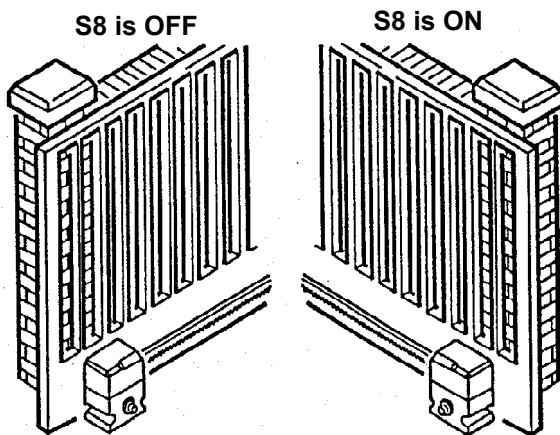
You have to define the gate leaf's midpoint, its fully opened position, and its fully closed position for the internal limit switches.

To set the limit switch module, be sure the gate is in manual mode (turn the Manual Release Lever clockwise).

**(a) Chain drive**



**(b) Rack and pinion drive**



**Figure 13. Set DIP switch S8 for your gate:**  
**(a) For a chain drive, S8 is ON when the gate closes to the left and OFF when the gate closes to the right;**  
**(b) for a rack and pinion drive, S8 is OFF when the gate closes to the left and ON when the gate closes to the right**

**Define the Midpoint**

Move the gate leaf by hand to exactly the half-opened position. The longer your gate leaf, the more important it is that you be precise in positioning the gate leaf exactly at the half-opened position.

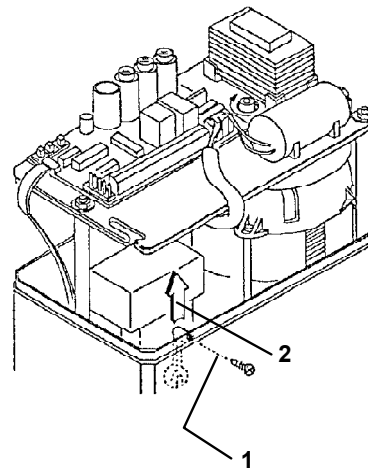
With the leaf in exactly the half-opened position, locate the retaining screw for the plastic tab that disengages the limit switch module from the operator (see Figure 14). Remove the retaining screw that holds the plastic tab.

**Caution:** Do not pull the plastic tab up unless the gate leaf is opened exactly halfway.

Now turn on the power to the gate operator. The ADL status indicator LED should be on. If it isn't on, call us before proceeding. The light should be on to confirm the working status of the ADL board.

The illuminated ADL LED also indicates the the operator is at its midpoint of potential travel. So, turn off the main power and pull the plastic tab up to engage the limit switch module.

Once you remove the plastic tab, you must test whether you properly defined the midpoint. To test the midpoint, turn on the main power and move the gate leaf by hand first in one direction and then in the other. The ADL LED should turn off when the gate leaves the midpoint and turn on when the gate is at the midpoint of travel.



1. Remove the retaining screw.
2. Pull the plastic tab up only if the gate is opened exactly halfway

**Caution:** Failure to remove the plastic tab or failure to remove it properly can result in the mechanical failure of the operator.

**Figure 14. Defining the midpoint**

Next, you can set the fully opened and fully closed positions for the gate leaf. You may set the limit switches in either order, but be sure to set both limit switches.

**Caution:** If you have not removed the plastic tab, you cannot set the limit switches for the fully opened or fully closed positions.

## Set the Opened Limit

**Caution:** Before setting a limit switch, verify that your gate does not exceed the limits for which your operator is designed. Refer to the technical data on page 4.

Set the opened limit switch by doing the following. Move the gate leaf by hand to the fully opened position.

After the gate is in the fully opened position, locate the FCA and RESET buttons on the control panel. Press the FCA button and hold it. Then also press the RESET button. Pressing both buttons, hold them down for a couple of seconds. Then release only the RESET button and continue to press down on the FCA button.

You should then hear one click from the panel and see the ADL status indicator LED blink once. Also, the FCA LED should go out to further confirm that you have set the opened limit. Now you can release the FCA button. You have set the limit switch for the fully opened position.

If *after* releasing the FCA button and *before* you move the gate you hear continual clicking and the ADL light blinks continually, proceed to set the closed limit.

## Set the Closed Limit

**Caution:** Before setting a limit switch, verify that your gate does not exceed the limits for which your operator is designed. Refer to the technical data on page 4.

To set the closed limit switch, do the following. Move the gate leaf by hand to the fully closed position. After you have the gate in the fully closed position, locate the RESET and FCC buttons on the control panel. Press the FCC button and hold it down. Then also press the RESET button. Pressing both buttons, hold them down for a couple of seconds. Then release only the RESET button, continuing to press down on the FCC button.

You should then hear one click from the panel and see the ADL status indicator LED blink once. Also, the FCC LED should go out to further confirm that the closed limit has been set. Now you can release the FCC button. You have now set the limit switch for the fully closed position.

If *after* releasing the FCC button and *before* you move the gate you hear continual clicking and the ADL light blinks continually, proceed to set the opened limit.

Note that you will not need to reset the limit switches if there is a power failure. The limit switch module remembers the limit switch settings.

## Relocating the Midpoint

Do not relocate the midpoint on your gate unless it is absolutely necessary. Relocating the midpoint of the gate leaf's travel is sometimes necessary: when an especially long gate leaf does not open or close far enough or when you are installing the operator on a different gate. An especially long gate leaf makes it possible to misjudge the midpoint of the leaf's travel.

To relocate the midpoint, disengage the drive of the operator (turn the Manual Release Lever clockwise) with the main power on. Then move the gate leaf by hand until the ADL light illuminates. (The ADL light is on when the operator is at its midpoint.) Now turn the main power off so that you can re-install the plastic tab.

**WARNING!** Turn the main power off before you re-install the plastic tab.

To re-install the plastic tab, first turn off the main power to the operator. Then, reach inside the operator from the gate leaf side and find the spring-loaded shaft that is below the Limit Switch Module. Press the spring loaded shaft away from the gate leaf while you insert the plastic tab down and over the other end of the shaft. Release the end of the shaft you were pressing so that it will grab the plastic tag and thus re-install it. If the shaft springs back toward the leaf, you have not properly installed the plastic tab.

Once the plastic tab is re-installed, you can re-establish the midpoint of the gate's travel as described above. Then you need to set both the opened and closed limits.

## Install Other Accessories

**WARNING!** Turn the main power off before you make any electrical connections or set any switches inside the operator.

You install other accessories to the 820 or 860 Operator according to the terminal wiring diagram shown in Figure 15.

Terminals 1 and 6 are the common for all installed opening, stop, and reversing devices. Terminal 2 is for your normally open (N.O.) opening device. Terminal 3 is for an N.O. partial opening (A/C) device *or* for an N.O. closing device, depending on the logical mode of operation you choose. If you do not install one of the normally closed devices (a stop or reversing device), then you need to connect its terminal (4 or 5, respectively) to terminal 1 (or 6) with a jumper.

Terminal 6 is the common you should use for any 24 VDC accessory. Terminal 7 supplies +24 VDC.

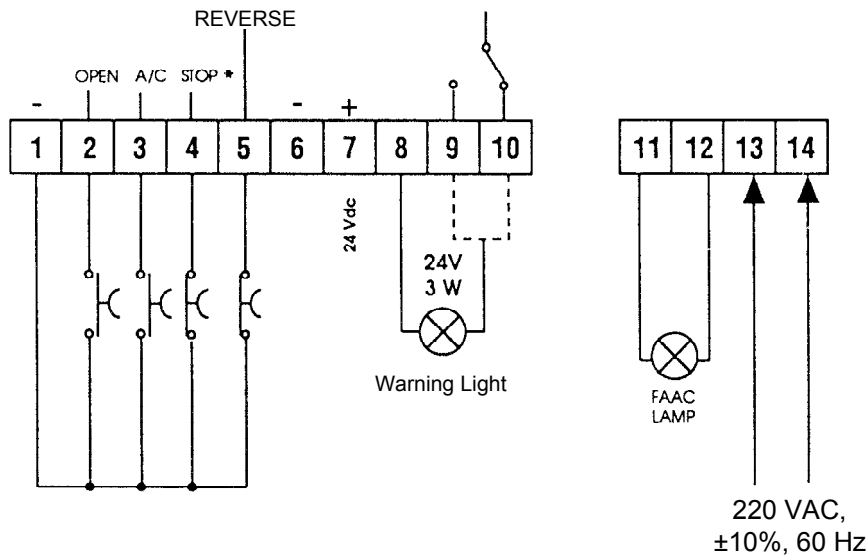
Terminals 8, 9, and 10 are for installing a warning light. Terminal 8 is common. The warning light function differs depending on whether you use terminal 9 or 10. See the tables on the previous pages for more detail.

Terminals 11 and 12 supply high-voltage power when the motor is running. You connect your main power source to terminals 13 and 14.

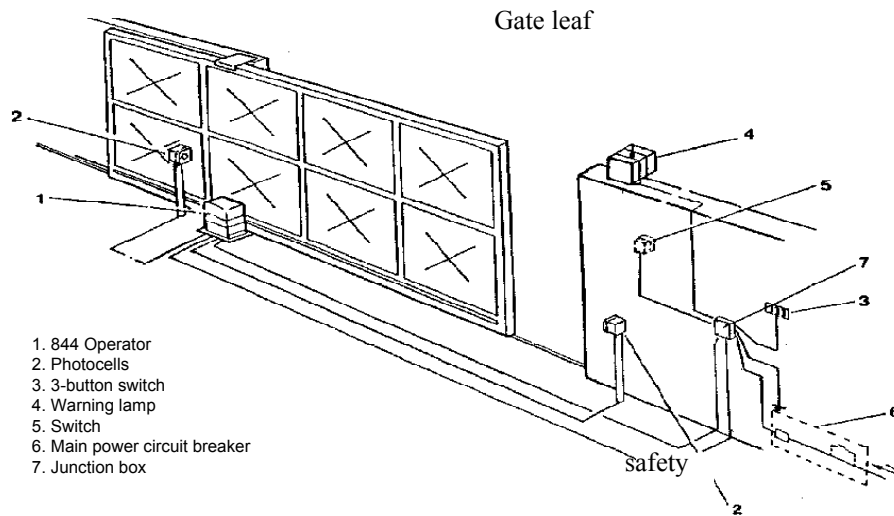
**Note:** Your standard 220 VAC power source meets the specification for 230 VAC, +6 or -10%.

If you are installing an 860 Operator without RC, it is especially important that you install additional reversing devices to compensate for the missing RC function. Three sets of photocells can improve entrapment protection (see Figure 16).

One set of photocells should protect the area where the gate moves on opening and should be connected between terminals 1 and 4 for stop logic. The other two sets should protect the area of the closing gate, inside and outside the property line, and should be connected in series to terminals 5 and 6.



\*If a STOP or SAFETY device is not installed, connect that terminal to terminal 1 with a jumper.



**Figure 16. Use three sets of photocells to improve entrapment protection**

## Remove the Bleed Screw

Using a 6-mm Allen wrench, you must remove the light-colored plastic cap that covers the clutch adjustment screw on the 820 or 860 Slide Gate Operator for two reasons (see Figure 17):

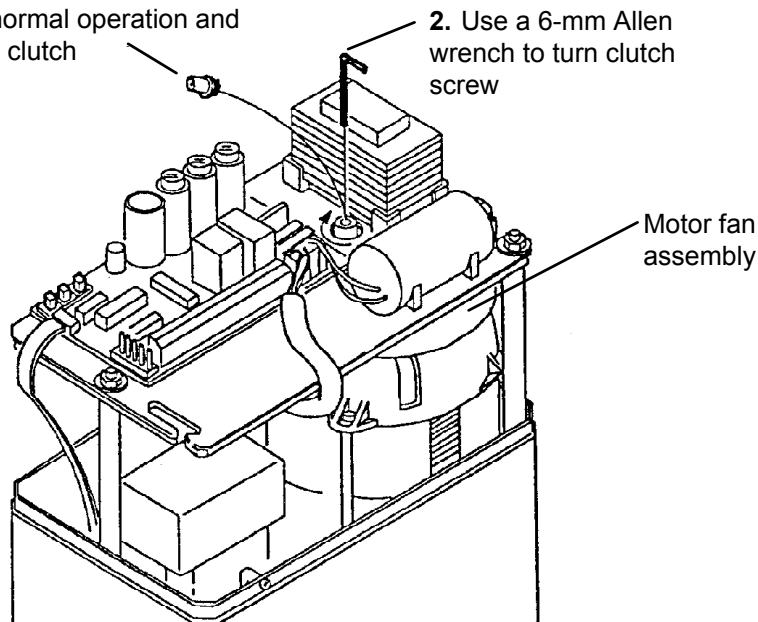
- You will break the plastic cap if you attempt to turn it, thinking it is the clutch adjustment screw.

- The plastic cap functions as a breather screw cap and must be removed during operation to allow the operator to "breathe."

You should save the plastic cap in case you ever transport the operator. Transporting the operator without the plastic cap installed allows oil to leak out if the operator is tipped over during transport.

1. Remove breather screw cap for normal operation and to adjust clutch

2. Use a 6-mm Allen wrench to turn clutch screw



**Figure 17. Adjusting the clutch**

## Adjust the Clutch of the Operator

**WARNING!** Turn the main power off before you make any electrical connections, set any switches inside the operator, or adjust the clutch.

Adjusting the clutch of the operator adjusts the pressure that the operator applies to the gate leaf. To adjust the clutch, you must first remove the plastic cap from the drive shaft (see Figure 17). Then, adjust the clutch with a 6-mm Allen wrench while holding the motor fan assembly to prevent the motor shaft from turning while you make the adjustment.

Turning the clutch screw clockwise tightens the clutch and results in more pressure being applied by the operator. Turning the clutch screw counterclockwise loosens the clutch and results in less pressure. Adjust the clutch so that the gate leaf moves with the least amount of pressure necessary to move it.

Faac International, Inc., recommends that the gate should stop all movement if it encounters a force of about 33 lb. (15 kg).

Once you have adjusted the clutch, do *not* replace the cap over the drive shaft.

**Caution:** Adjust the clutch of an 860 Operator with the optional RC (reverse on contact) function very carefully. Realize that the RC function may or may not be available on your operator: Gates requiring excessive and uneven pulling force can cause the RC function to not work. If after adjusting the clutch of your operator the RC function still does not work, call our technical department for assistance.

**WARNING!** The 860 Operator without RC does not have a reverse on contact function. This makes the adjustment of the clutch critical: The gate leaf should move with the least amount of pressure necessary. In addition, FAAC strongly recommends you install reversing devices (see Figure 16).

# Maintenance

**WARNING!** Turn the main power to the operator off before performing any maintenance or repair operations. The manufacturer recommends that only qualified personnel check and maintain the equipment.

The FAAC recommended maintenance schedule varies according to the frequency of use of the operator, whether lightly used (once or twice an hour on average) or heavily used (many times an hour on average).

## 1. Check the oil.

To check the oil level, remove the black plastic, hexagonal oil cap beneath the control panel platform inside the 820 or 860 operator. A dip stick is attached to the bottom of the oil cap for checking the oil. The oil level should be at or slightly above the mark on the dip stick.

Light use: check once per year  
Heavy use: check every 6 months

## 2. Change the oil.

Changing the oil requires removing the operator from its foundation plate and removing the cover and the platform to which the control panel is attached. This allows you easy access to the black plastic, hexagonal oil loading cap.

Remove the oil loading cap. Drain the oil from the operator by pumping the oil out or by gently tipping the operator to its side so that the oil can drain. Fill the operator with oil (about 1 qt [0.9 liter]) and reassemble the operator and remount it on its foundation plate.

Light use: every 4 years  
Heavy use: every 2 years

## 3. Check the clutch adjustment.

Light use: once per year  
Heavy use: every 6 months

# Troubleshooting

**WARNING!** Turn the main power off before you make any electrical connections or set any switches inside the operator.

**Status indicator LEDs under normal conditions**

Normal conditions:	LEDs							
	ADL (LD5)	FCA (LD6)	FCC (LD7)	S* (LD8)	OPEN (LD1)	A/C (LD2)	STOP (LD3)	FTSW (LD4)
Gate is closed	Off	On	Off	On	Off	Off	On	On
Gate is fully opened	Off	Off	On	On	Off	Off	On	On
Gate is half opened	On	On	On	On	Off	Off	On	On

\* The S indicator LED is on as long as the board is receiving power.

**Problem:** The gate is closed and will not open when I send it a signal to open.

**Solution:**

If the OPEN light does not illuminate when you send the opening signal, then try shorting between terminals 1 and 2. If the short causes the gate to open, then the problem is in the activating device itself.

If the STOP LED is not lit, verify that a jumper or an accessory is installed between terminals 1 and 4.

Check fuses F1 and F2.

If the motor is on, then make sure the clutch adjustment supplies enough force to move the gate leaf.

Make sure the Manual Release Lever has not disengaged the drive motor. The Manual Release Lever should be rotated counterclockwise.

**Problem:** The gate is opened and will not close when I send it a signal to close.

**Solution:**

Check to see if the FTSW light is illuminated. If it isn't, then something is triggering the reversing device. If you have no reversing devices installed, then connect a jumper between terminals 1 and 5.

**Problem:** The gate is open, and when I signal the gate to close, the motor runs a little but the gate doesn't close.

**Solution:**

The setting for DIP switch S8 may be incorrect. Switch S8 defines the direction in which the leaf moves when the gate is closing. Compare your gate installation to Figure 13 to determine your gate's orientation and then check the setting of switch S8.

**Problem:** The gate will not open (or close) completely.

**Solution:**

If the motor is running, then check your clutch adjustment. Tighten the clutch if necessary.

You may have set a limit switch incorrectly. To define the problem, check your LEDs to see if the FCA light is off for the fully opened position (or the FCC light is off for the fully closed position).

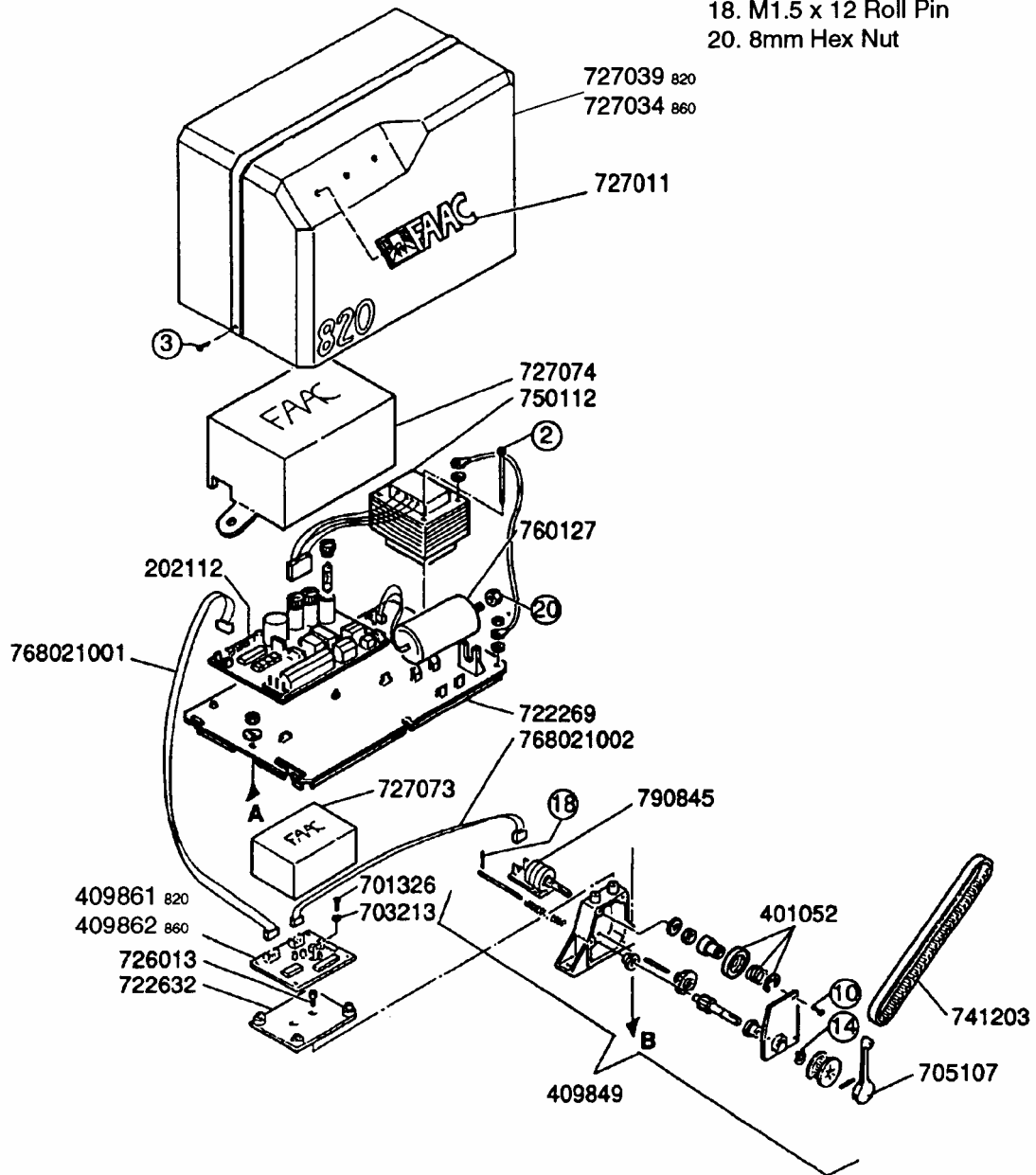
If the LEDs are correct, check first for an obstruction in the path of the moving gate leaf. If there is no obstruction, then try setting the limit switch for the position again.





# Exploded View 820/860 Electronic Parts

- 2. M3 x 45 Socket Head Screw
- 3. M4 x 6 Phillips Head Screw
- 10. M3 x 7 Hex Head Bolt
- 14. E8 External Snap Ring
- 18. M1.5 x 12 Roll Pin
- 20. 8mm Hex Nut



cod. 923031

0.1	01.94	00.00	
-----	-------	-------	--



## Limited Warranty

*To the original purchaser only:* FAAC International, Inc., warrants, for twenty-four (24) months from the date of invoice, the gate operator systems and other related systems and equipment manufactured by FAAC S.p.A. and distributed by FAAC International, Inc., to be free from defects in material and workmanship under normal use and service for which it was intended *provided* it has been properly installed and operated. FAAC International, Inc.'s obligations under this warranty shall be limited to the repair or exchange of any part of parts manufactured by FAAC S.p.A. and distributed by FAAC International, Inc. Defective products must be returned to FAAC International, Inc., freight prepaid by purchaser, within the warranty period. Items returned will be repaired or replaced, at FAAC International, Inc.'s option, upon an examination of the product by FAAC International, Inc., which discloses, to the satisfaction of FAAC International, Inc., that the item is defective. FAAC International, Inc. will return the warranted item freight prepaid. The products manufactured by FAAC S.p.A. and distributed by FAAC International, Inc., are not warranted to meet the specific requirements, if any, of safety codes of any particular state, municipality, or other jurisdiction, and neither FAAC S.p.A. or FAAC International, Inc., assume any risk or liability whatsoever resulting from the use thereof, whether used singly or in combination with other machines or apparatus.

Any products and parts not manufactured by FAAC S.p.A. and distributed by FAAC International, Inc., will carry only the warranty, if any, of the manufacturer. This warranty shall not apply to any products or parts thereof which have been repaired or altered, without FAAC International, Inc.'s written consent, outside of FAAC International, Inc.'s workshop, or altered in any way so as, in the judgment of FAAC International, Inc., to affect adversely the stability or reliability of the product(s) or has been subject to misuse, negligence, or accident, or has not been operated in accordance with FAAC International, Inc.'s or FAAC S.p.A.'s instructions or has been operated under conditions more severe than, or otherwise exceeding, those set forth in the specifications for such product(s). Neither FAAC S.p.A. or FAAC International, Inc., shall be liable for any loss or damage whatsoever resulting, directly or indirectly, from the use or loss of use of the product(s). Without limiting the foregoing, this exclusion from liability embraces a purchaser's expenses for downtime or for making up downtime, damages for which the purchaser may be liable to other persons, damages to property, and injury to or death of any persons. Neither FAAC S.p.A. or FAAC International, Inc., assumes nor authorizes any person to assume for them any other liability in connection with the sale or use of the products of FAAC S.p.A. or FAAC International, Inc. The warranty hereinabove set forth shall not be deemed to cover maintenance parts, including, but not limited to, hydraulic oil, filters, or the like. No agreement to replace or repair shall constitute an admission by FAAC S.p.A. or FAAC International, Inc., of any legal responsibility to effect such replacement, to make such repair, or otherwise. This limited warranty extends only to wholesale customers who buy directly through FAAC International, Inc.'s normal distribution channels. FAAC International, Inc., does not warrant its products to end consumers. Consumers must inquire from their selling dealer as to the nature and extent of that dealer's warranty, if any.

**This warranty is expressly in lieu of all other warranties expressed or implied including the warranties of merchantability and fitness for use. This warranty shall not apply to products or any part thereof which have been subject to accident, negligence, alteration, abuse, or misuse or if damage was due to improper installation or use of improper power source, or if damage was caused by fire, flood, lightning, electrical power surge, explosion, wind storm, hail, aircraft or vehicles, vandalism, riot or civil commotion, or acts of God.**

**FAAC International, Inc.  
303 Lexington Avenue  
Cheyenne, WY 82007**