



Opening a Whole New World: FAAC Swing Gate Systems



Model 412

High and Low Voltage

The Model 412 electromechanical swing gate operator is designed specifically for light single family residential use.



- Swing Gate Operators
- Slide Gate Operators
- Barrier Gate Operators
- Accessories

FAAC USA

An ISO 9001 Certified Company

FAAC is the world's largest specialized manufacturer of gate operating equipment.

**UL 325
COMPLIANT**
CSI # 02820 -
Gate Operators

Model 412

Electromechanical Swing Gate Operators

**UL 325
COMPLIANT**
CSI # 02820 -
Gate Operators

The Model 412 electromechanical swing gate operator is designed specifically for light single family residential use.

Standard features include slow down "soft stop" and mechanical locking in the opened and closed positions. A convenient manual release is also standard.

The Model 412, like other FAAC swing gate operators, is inherently safer because it has fewer "pinch points." In addition, the force it applies to move the gate is adjustable for extra entrapment protection.

In the event of power failure, a battery back up is standard on the Model 412 Low Voltage and an available option on the Model 412 High Voltage.

The 412 can be mounted inside the gate and still allow the gate to open to the inside or to the outside. All FAAC operators can be finished to blend with your gate.

All swing gates require gate stops that limit the travel of each gate leaf and thus protect the operator. Optional positive stops are available.

NOTE: To guarantee the safety and efficiency of its equipment, FAAC strongly recommends that qualified personnel test the safety system on an annual basis, as well as maintain the overall hydraulic or mechanical system.

Model 412 Kit includes:

(for bi-parting gates)

- Two gate operators with mounting hardware
- One control panel which operates single leaf or bi-parting gates
- One 14 x 16 in. weather resistant UL Listed fiberglass enclosure
- Two photobeam sets for opening and closing reversing devices
- One plug-in radio receiver
- Two radio transmitters
- Two batteries and plug-in transformer (Model 412 Low Voltage only)
- Four warning signs

NOTE: FAAC packages their operators to be fully UL-325 compliant, right out of the box, which means there's no need to purchase any additional peripherals.

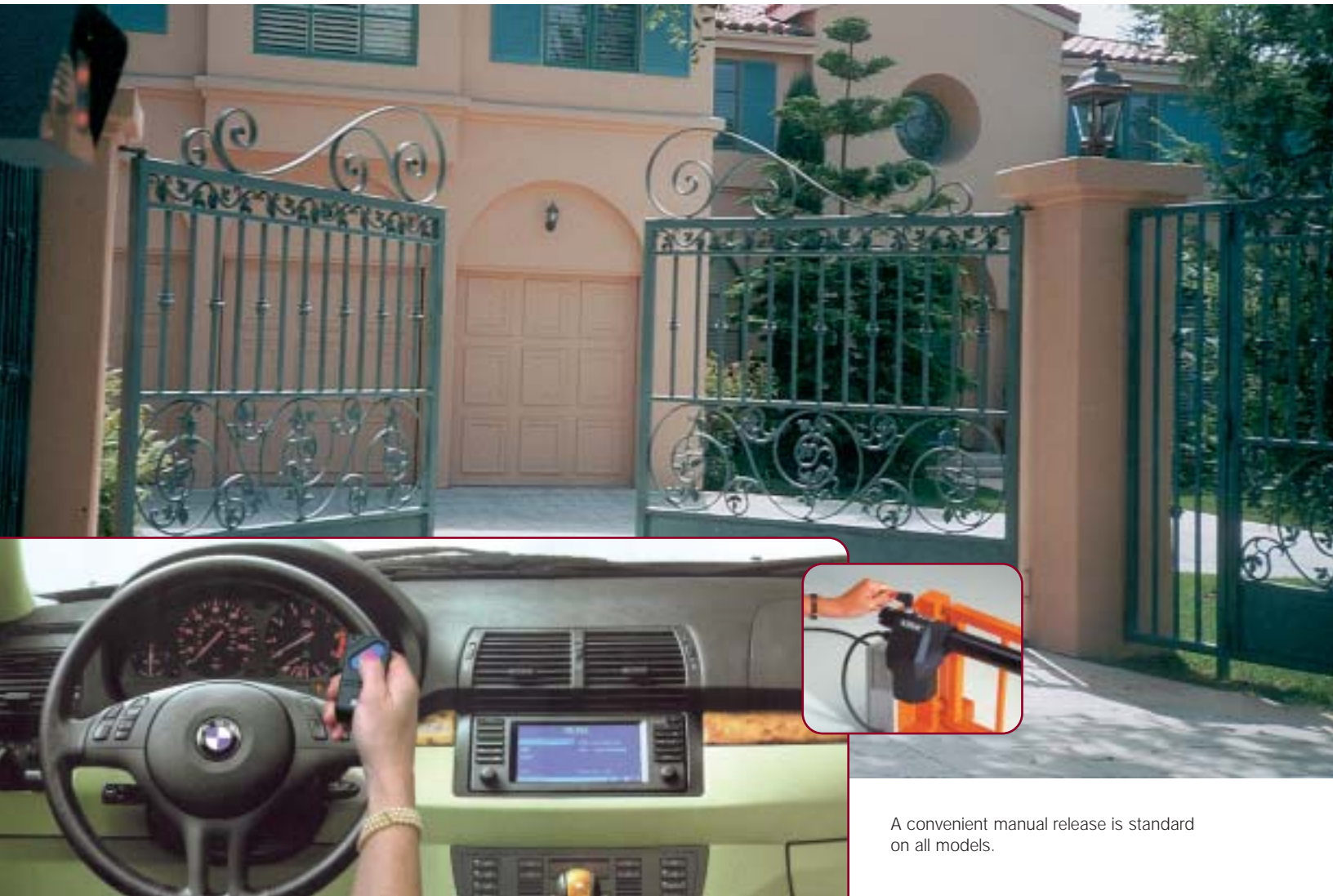

A convenient manual release is standard on all models.

Use FAAC to build a complete gate system

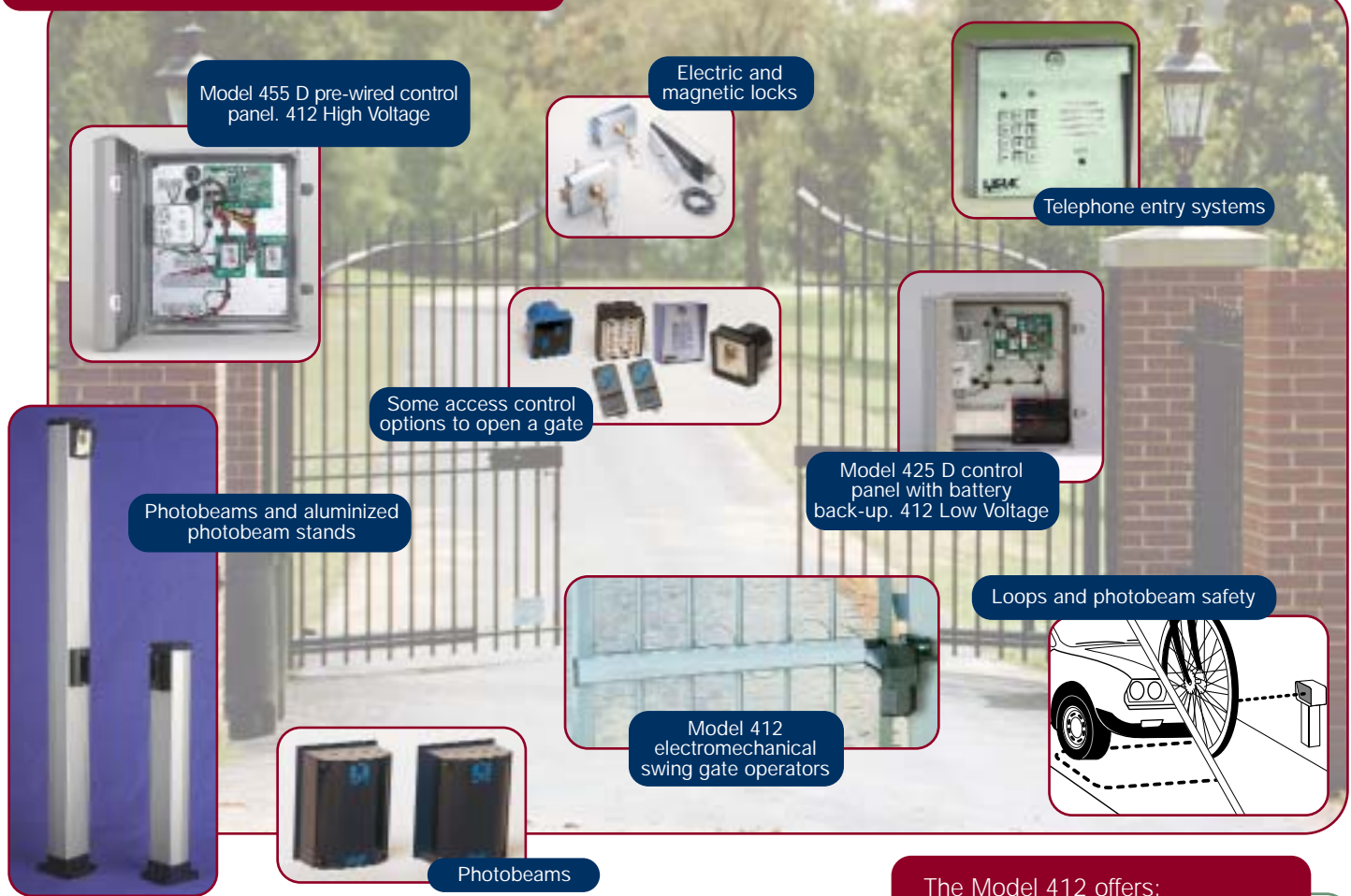

The Model 412 offers:

- Designed for light residential, single family use
- UL 325 compliant
- Slow down "soft stop"
- Mechanical locking in the opened and closed positions
- Easy interconnection of loop detectors, photocells, etc. to reverse a gate if an obstacle is sensed
- Easy interconnection of actuating devices like remote control radios, key pads and telephone entry systems
- On-board diagnostic LEDs
- Convenient manual release in case of power failure

Model 412 High Voltage includes:

- One 455 D control panel which operates single leaf or bi-parting gates
- Choice of 6 operating modes including:
 - "pulse-to-open, pulse-to-close"
 - automatic timed closure
 - "man present" (separate open and close contacts)
- 30 VDC power for accessories
- 115 or 230 VAC

Model 412 Low Voltage includes:

- One 425 D control panel which operates single leaf or bi-parting gates
- Choice of 2 operating modes including:
 - "pulse-to-open, pulse-to-close"
 - automatic timed closure
- Slow-down "soft stop" feature
- On-board diagnostic LEDs
- Battery back-up included
- 24 VDC (transformer)

Positive gate stops

Positive gate stops, which limit the travel of each gate leaf, are required in the opened and closed positions for all gate systems using FAAC operators.

FAAC has two innovative positive stops. The Model 70 is an adjustable gate stop that attaches slightly above the space between the operator and gate. The Model 80 concealed stop is totally hidden since it is attached to the operator underneath the protective cover.

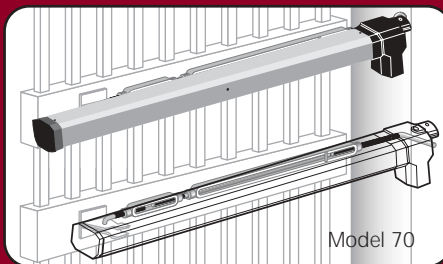

Model 70



Model 80

Features include:

- Stainless steel construction
- Mounts with existing FAAC hardware and does not require additional attachment points
- Accommodates inward or outward swing with no additional fabrication
- Maximum degrees of swing: limited by operator
- Maximum leaf length & weight: limited by operator

UL 325 Class Descriptions & FAAC Operators

| Class | FAAC Models | Duty Cycle | Typical Use |
|---------|---|-----------------|---|
| Class 1 | 400, 412, 402 422, 750, 760 620, 640, 885 | Limited duty | •Home use •Small apartment building, up to 4 units per building, limited public access |
| Class 2 | 400, 620, 640 885 | Continuous duty | •Apartment buildings •Open public access |
| Class 3 | 400, 620, 640 885 | Continuous Duty | •No public access |
| Class 4 | 620, 640, 885 | Continuous Duty | •Prison related security |

Duty Cycle

The duty cycle achieved by a swing gate operator in terms of "operations per hour" is, in large part, a function of the installation. For example, an operator swinging a leaf through 125° will be able to complete fewer operations per hour than the same operator swinging only 90°.

The duty cycles listed below reflect performance at an ambient temperature of 72° F (22° C) and at normal voltages of 115 or 230 VAC. Changes in environmental conditions, voltage and gate condition will affect achievable duty cycle.

| FAAC Operator Model | Cycles per hour |
|---------------------|-----------------|
| 400 | 80 |
| 402 | 30 |
| 412 | 50 |
| 422 | 30 |
| 750 | 30 |
| 760 | 30 |



Model 425 D low voltage control panel with battery back-up and hinged, lockable fiberglass enclosure

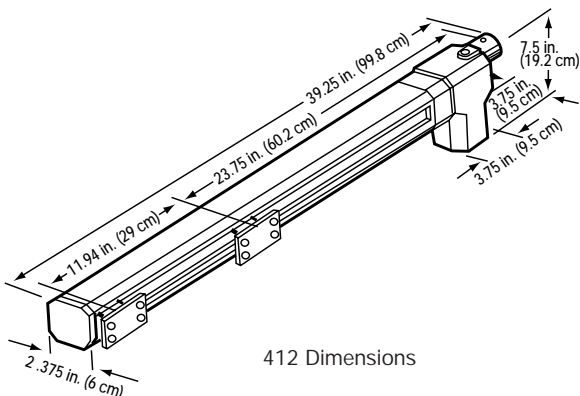

412 Dimensions

Specifications

| Parameter | Model 412 High Voltage | Model 412 Low Voltage |
|-------------------------------------|---|---|
| Application | Single family residence, single leaf or bi-parting gate (vehicles only, not for pedestrian use) (not recommended for solid gates) | |
| Cycles per hour | 18 | 50 |
| Maximum gate swing | 110 degrees | 110 degrees |
| 90 degree opening time | 13 seconds | 13 seconds |
| Maximum weight per gate leaf | 500 pounds (226.8 kg) | 500 pounds (226.8 kg) |
| Maximum length per gate leaf | 14 feet (4.2 m) | 14 feet (4.2 m) |
| Approx. operating temperature range | -4°F to 131°F (-20°C to 55°C) | |
| Mechanical locking | Available in opened and closed positions | |
| Voltage | 115 VAC or 230 VAC | Primary: 115 VAC Secondary: 24 VDC (transformer) |

Note: Operator specifications are approximate. Environmental factors can change the performance of the operator. Your installer will advise you which model of operator will work best for your site and application.

Speed and leaf length

Some thought should be given to the speed at which the gate will travel. The longer the gate leaf, the faster the traveling edge must move to clear an area in a given amount of time.

A speed of 40 feet/minute (12.2 meters/minute) is a "bench mark" velocity. It permits efficient operation while limiting the energy in the moving gate leaf. The lower the energy, the less chance of damage to property or injury to people in the event of accidental contact with the moving gate.

Examples illustrating the relationship between operator speed, gate leaf length, and the velocity of the leaf's traveling edge

| Speed options available (time needed to swing a gate 90°) | EXAMPLE: Velocity of the traveling edge of an 8 ft (2.4 m) leaf [in feet/m and (meters/m)] | Longest leaf which can be used if the velocity of the traveling edge is not to exceed 40 fpm (12.2 mpm) |
|---|--|---|
| 6 sec. | 126 fpm (38 mpm) | 2.5 ft (0.8 m) |
| 12 sec. | 63 fpm (19 mpm) | 5 ft (1.5 m) |
| 15 sec. | 50 fpm (15 mpm) | 6 ft (1.9 m) |
| 17 sec. | 44 fpm (14 mpm) | 7.5 ft (2.3 m) |
| 23 sec. | 33 fpm (10 mpm) | 10 ft (3 m) |

Mounting Geometry

Sometimes the mounting measurements will result in a flush mounting. Other applications require a column to be notched in order to accommodate the correct mounting geometry.

Note: If, in your installation, notching a column is not practical, other solutions are available:

- Install operators using an outward swing.
- Upgrade to an operator with more mounting flexibility.
- Use an in-ground operator.

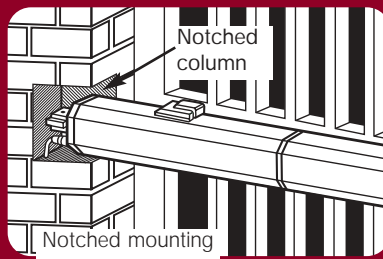
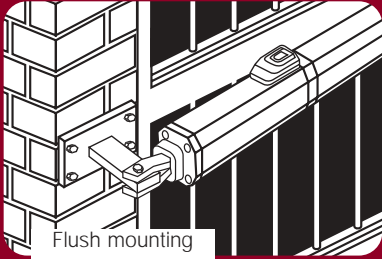

Decisions regarding mounting geometry apply to gate mounted operators: Models 400, 402, 422 and 412.

As shown in the diagrams below, the operators must be mounted at an angle to the gate. Correct mounting geometry assures that the desired degrees of swing are achieved, that the gate speed is correct, and that the operator and gate will operate properly and have a long life.

Mounting dimensions for OUTWARD-swinging 412 operators, top view

| Measurement ^a | 90° Swing | 110° Swing |
|--------------------------|--------------------|--------------------|
| A | 5.75 in. (14.5 cm) | 4.88 in. (12.5 cm) |
| B | 5.75 in. (14.5 cm) | 4.88 in. (12.5 cm) |

WARNING! A and B should differ by no more than .5 in. (1.27 cm). Larger differences may dangerously alter the speed of operation.

| | | |
|---|---------------------------------------|-----------------|
| C | 24.25 in. (62 cm) | |
| D | 4 in. (10 cm) | 3.13 in. (8 cm) |
| E | Absolute minimum of 3.13 in. (8 cm) | |
| F | Absolute minimum of 1.75 in. (4.5 cm) | |

^a Gate speed increases as the dimensions A and B decrease. The torque adjustment may also affect the gate speed.

^b The sum of A and B must equal a minimum of 3.625 in. (9 cm).

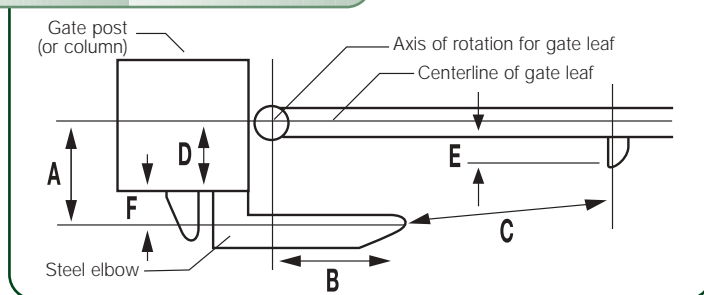

Mounting dimensions for INWARD-swinging 412 operators, top view

| Measurement ^a | 90° Swing | 110° Swing |
|--------------------------|--------------------|--------------------|
| A | 5.75 in. (14.5 cm) | 4.88 in. (12.5 cm) |
| B | 5.75 in. (14.5 cm) | 4.88 in. (12.5 cm) |

WARNING! A and B should differ by no more than .5 in. (1.27 cm). Larger differences may dangerously alter the speed of operation.

| | | |
|---|---------------------------------------|-----------------|
| C | 35.125 in. (89.2 cm) | |
| D | 4 in. (10 cm) | 3.13 in. (8 cm) |
| E | 3.13 in. (8 cm) | |
| F | Absolute minimum of 1.75 in. (4.5 cm) | |

^a Gate speed increases as the dimensions A and B decrease. The torque adjustment may also affect the gate speed.

^b The sum of A and B must equal a minimum of 3.625 in. (9 cm).

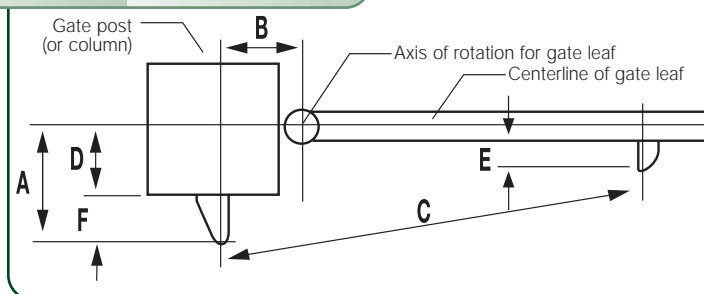

How many degrees of swing are required?

- One FAAC gate operator (Model 750) can swing a gate up to 180°.
- All models of FAAC operators can swing a gate at least 90°.
- Openings which require swings greater than 90° will need certain FAAC operator models.
- The swing of an operator applies equally to inward or outward swinging gates.

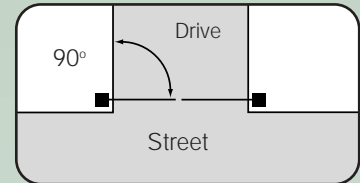

All FAAC operators:
Models 412, 402, 422, 400,
750, 760

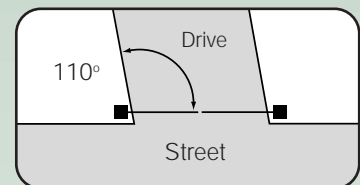

Models 412, 400, 750, 760.

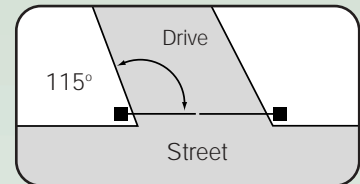

Models 400, 750, 760.

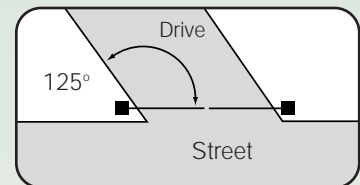

Models 400 EG
(extended geometry),
750, 760.

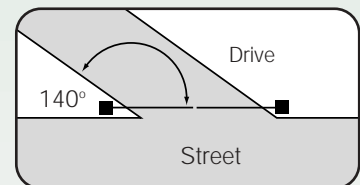

Models 750 (up to 180°),
760 (up to 148°
with "soft stop")



HEADQUARTERS
Bologna, Italy

RESEARCH & DEVELOPMENT
Bologna, Italy
Dublin, Ireland

PRODUCTION FACILITIES
Bologna, Italy

SUBSIDIARY OFFICES
Wals-Siezenheim, Austria
Corbas-Lyon, France
Freilassing, Germany
Alcobendas-Madrid, Spain
Illnau, Switzerland
Basingstoke, Hampshire, U.K.
Cheyenne, Wyoming, U.S.A.

FAAC's U.S.
headquarters
in Cheyenne,
Wyoming



Founded in 1965, FAAC has risen to become the world's largest specialized manufacturer of automated operators for swing, slide and barrier gate systems.

International company headquarters, research & development and primary production facilities are located in Bologna, Italy. Dublin, Ireland is the site of FAAC's research, design and production facility for electronic controls including photocells, radio controls and code opening systems.



FAAC International, Inc.
303 Lexington Avenue
Cheyenne, WY 82007
1-800-221-8278
Fax: (307) 632-8148
Web: www.faacusa.com

