

UL LISTINGS AND INSTRUCTIONS

INSTALLATION INSTRUCTIONS REGARDING THE GATE OPERATOR

- A) Install the gate operator only when:
- 1) The operator is appropriate for the construction and the usage Class of the gate.
 - 2) **All openings of a horizontal slide gate are guarded or screened from the bottom of the gate to a minimum of 4 feet (1.2 m) above the ground to prevent a 2 1/4inch (57.15 mm) diameter sphere from passing through the openings anywhere in the gate, and in that portion of the adjacent fence that the gate covers in the open position.**
 - 3) All exposed pinch points are eliminated or guarded, and
 - 4) Guarding is supplied for exposed rollers.
- B) The operator is intended for installation only on gates used for vehicles. Pedestrians must be supplied with a separate access opening.
- C) The gate must be installed in a location so that enough clearance is supplied between the gate and adjacent structures when opening and closing to reduce the risk of entrapment. Swinging gates shall not open into public access areas.
- D) The gate must be properly installed and work freely in both directions prior to the installation of the gate operator.
- E) -
- F) Controls must be far enough from the gate so that the user is prevented from coming in contact with the gate while operating the controls. Controls intended to be used to reset an operator after 2 sequential activations of the entrapment protection device or devices must be located in the line of sight of the gate outdoor or easily accessible controls shall have a security feature to prevent unauthorized use.
- G) All warning signs and placards must be installed where visible in the area of the gate.

UL LISTINGS AND INSTRUCTIONS

- H) For a gate operator utilizing a non-contact sensor such as a photo beam:
- 1) See instructions on the placement of non-contact sensor for each Type of application,
 - 2) Care shall be exercised to reduce the risk of nuisance tripping, such as when a vehicle trips the sensor while the gate still moving, and
 - 3) One or more non-contact sensors shall be located where the risk of entrapment or obstruction exists, such as the perimeter reachable by a moving gate or barrier.
- I) For a gate operator utilizing a contact sensor such as an edge sensor:
- 1) One or more contact sensors shall be located at the leading edge, trailing edge and postmounted both inside and outside of a vehicular horizontal slide gate.
 - 2) One or more contact sensors shall be located at the bottom edge of a vehicular vertical lift gate.
 - 3) One or more contact sensors shall be located at the pinch point of a vehicular vertical pivot gate.
 - 4) A hardwired contact sensor shall be located and its wiring arranged so that the communication between the sensor and the gate operator is not subjected to mechanical damage.
 - 5) A wireless contact sensor such as the one that transmits radio frequency (RF) signals to the gate operator for entrapment protection functions shall be located where the transmission of the signals are not obstructed or impeded by building structures, natural landscaping or similar obstruction. A wireless contact sensor shall function under the intended end-use conditions.

UL LISTINGS AND INSTRUCTIONS

IMPORTANT SAFETY INSTRUCTIONS

WARNING - To reduce the risk of injury or death:

1. READ AND FOLLOW ALL INSTRUCTIONS.
2. Never let children operate or play with gate controls. Keep the remote control away from children.
3. Always keep people and objects away from the gate while the gate is in operation. NO ONE SHOULD CROSS THE PATH OF A MOVING GATE.
4. Test the gate operator monthly. The gate MUST reverse on contact with a rigid object or stop when an object activates the non-contact sensors. After adjusting the force or the limit of travel, retest the gate operator, Failure to adjust and retest the gate operator properly can increase the risk of injury or death.
5. Use the emergency release only when the gate is not moving. Make sure the power for the gate operator is off.
6. KEEP GATES PROPERLY MAINTAINED. Read the manual. Have a qualified service person make repairs to the gate or gate hardware.
7. The entrance is for vehicles only. Pedestrians must use separate entrance.
8. SAVE THESE INSTRUCTIONS.

UL LISTINGS AND INSTRUCTIONS

Gate – A moving barrier such as a swinging, sliding, raising lowering, rolling, or like, barrier, that is a stand-alone passage barrier or is that portion of a wall or fence system that controls entrance and/or egress by persons or vehicles and completes the perimeter of a defined area.

Vehicular horizontal slide-gate operator (or system) – A vehicular gate operator (or system) that controls a gate which slides in a horizontal direction that is intended for use for vehicular entrance or exit to a drive, parking lot, or the like.



Residential vehicular gate operator – Class I – A vehicular gate operator (or system) intended for use in a home of one-to four single family dwelling, or a garage or parking area associated therewith.

Commercial/General access vehicular gate operator – Class II – A vehicular gate operator (or system) intended for use in a commercial location or building such as a multi-family housing unit (five or more single family units) hotel, garages, retail store or other building servicing the general public.

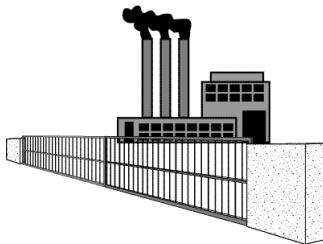
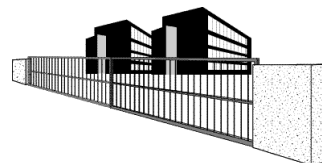

Commercial/General access vehicular gate operator – Class III – A vehicular gate operator (or system) intended for use in a industrial location or building such as a factory or loading dock area or other locations not intended to service the general public.

Restricted access vehicular gate operator – Class IV – A vehicular gate operator (or system) intended for use in a guarded industrial location or building such as an airport security area or other restricted access locations not servicing the general public, in which unauthorized access is prevented via supervision by security personnel.

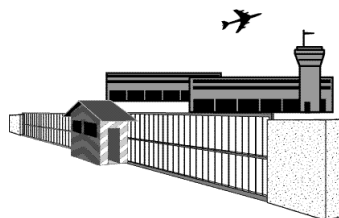

INSTALLATION OF GATE OPERATOR

Make sure the hardware springs are balanced and the gate opens and closes smoothly. Mark the center of the gate frame.

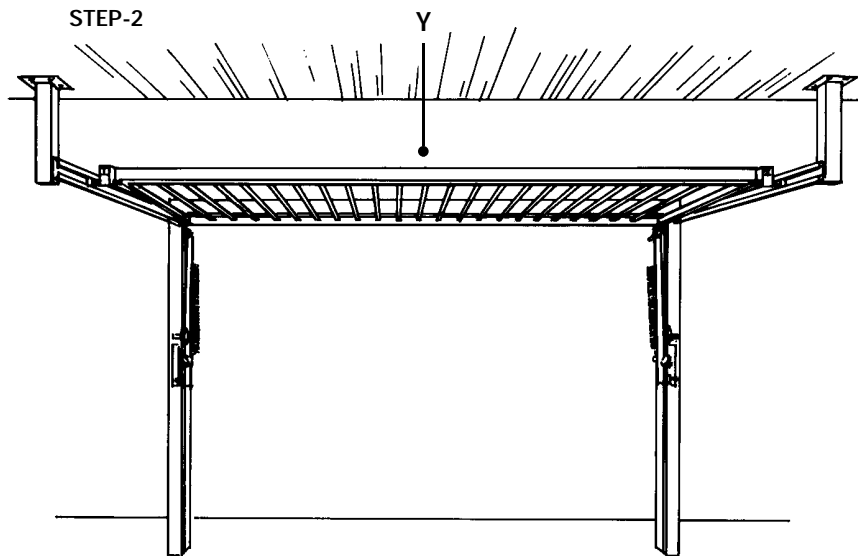
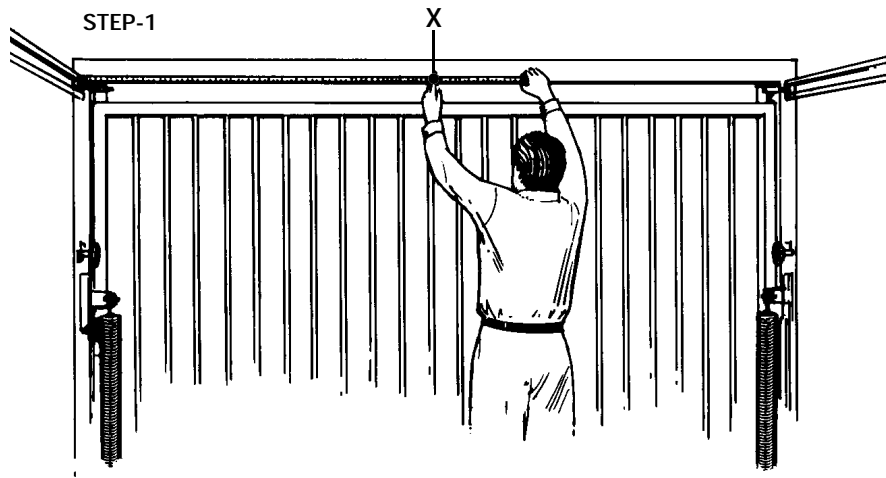

Open the gate and mark the center point of the gate on the ceiling.

MOUNTING THE GATE OPERATOR

STEP-3

Make sure the head bracket is centered with mark X. Weld or bolt the end of the track (head bracket) on the mark X as shown in this picture.

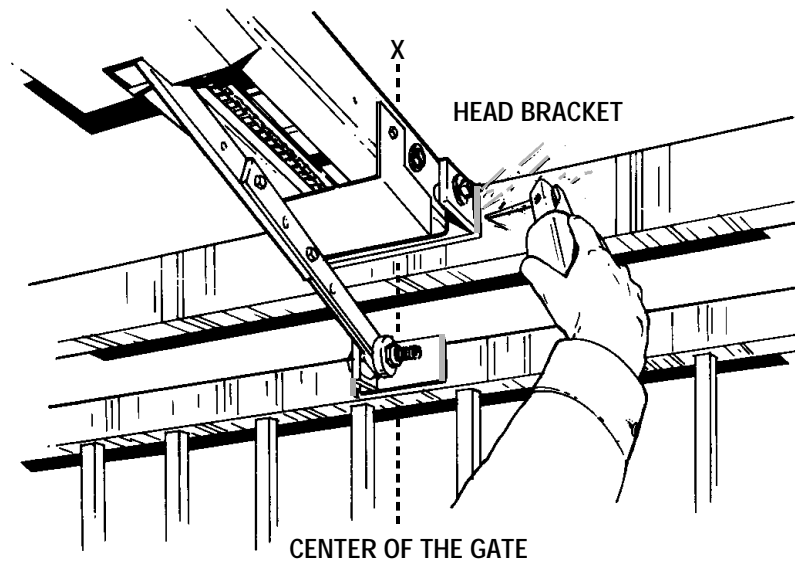

STEP-4

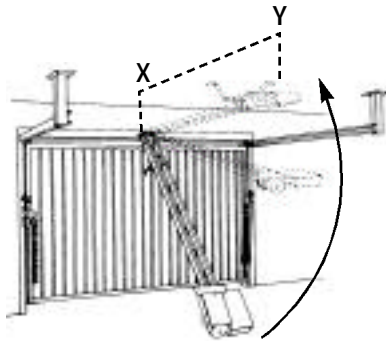

Lift the operator and align the center of the track with mark X.

STEP-5

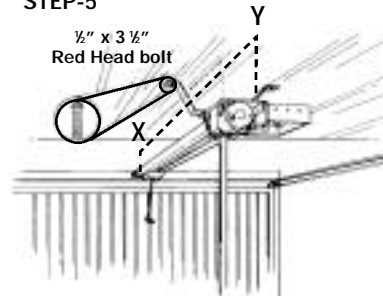

Have someone hold the operator in place or use something as a support post, and bolt to ceiling. (A support post is not part of the gate operator. Use only for installation).

ADJUSTING GATE TRAVELING DISTANCE

STEP-6

BEFORE ADJUSTING DO THE FOLLOWING:

- 1 - Shut off the power
- 2 - Push the plate inward roll the nut in the direction desired
- 3 - Turn the power on
- 4 - If the gate needs some more adjustment repeat the process

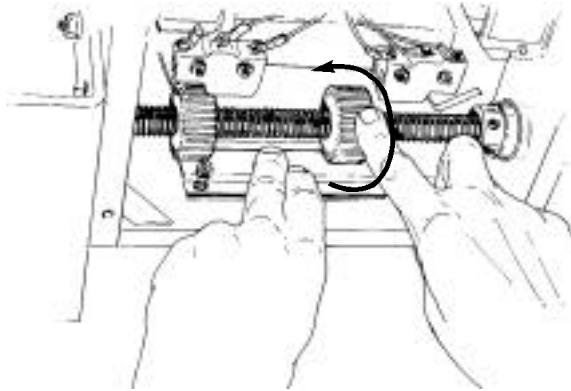

HOW TO CONNECT POWER (120V)

STEP-7

BLACK = 115VAC
WHITE = NEUTRAL
GREEN = GROUND

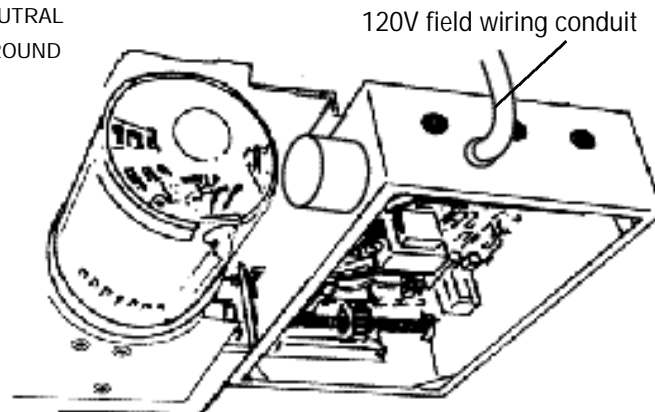

TWO-WAY ADJUSTABLE REVERSING SENSOR

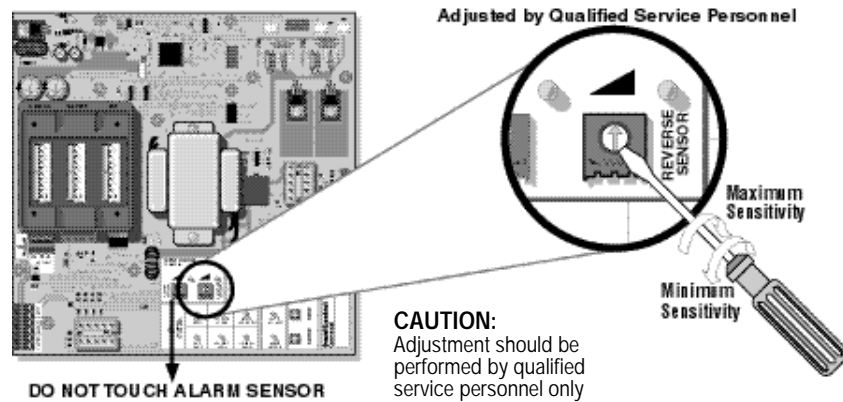

STEP-8

The level of sensitivity has to do with the weight of the gate and the condition of installation. It is too sensitive if the gate stops or reverses by itself. It is not sensitive enough if the gate hits an object and does not stop or reverse.



CAUTION: If the power supply to the gate operator is less than 99 volts, adjust the alarm by turning the alarm adjustment clockwise enough to actuate the alarm when obstructed but not sensitive enough for false triggering to occur.

ADJUSTABLE TIMER

STEP-9

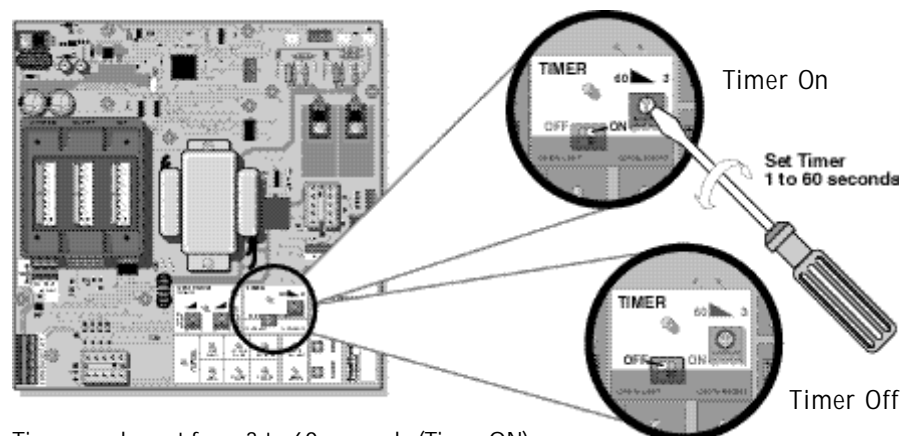

Timer can be set from 3 to 60 seconds (Timer ON),
or for push open/push close type operation (Timer OFF).

TERMINAL INPUT CONNECTIONS

STEP-10

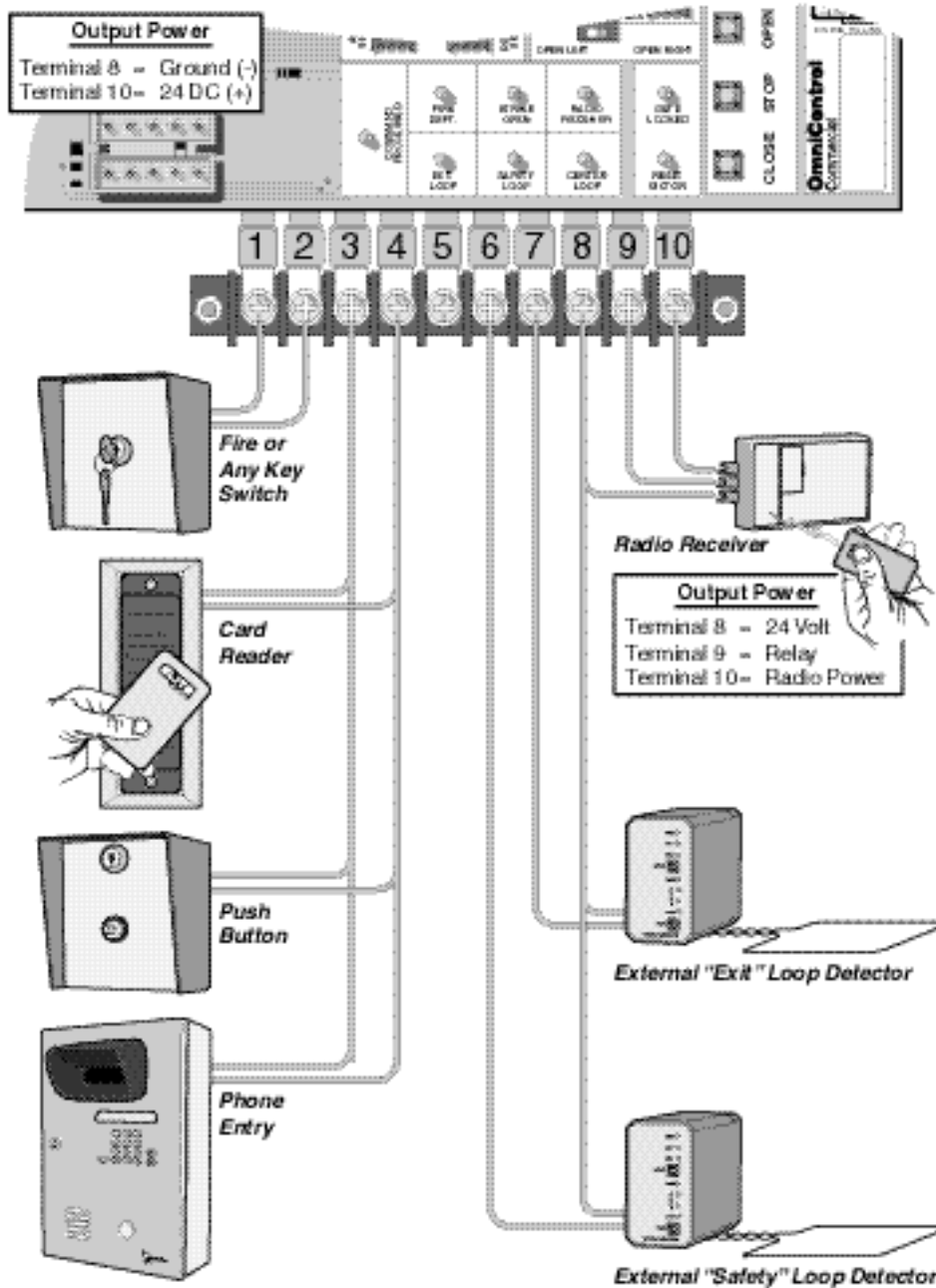

CAUTION! - READ THESE INSTRUCTIONS

STEP-11

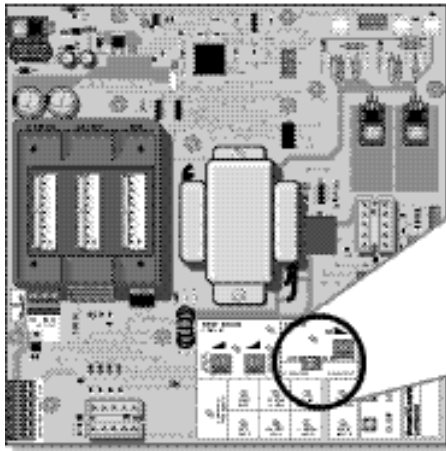

Make sure the system is open to left.

IMPORTANT INFORMATION

STEP-12

Installers are required to adhere to this procedure: The UL required Warning Signs must be installed in plain view and on both sides of each commercial gate installed. Each sign is made with fastening holes in each corner and should be permanently secured in a suitable manner. Also the warning sticker should be placed on the operator so it is clearly visible.

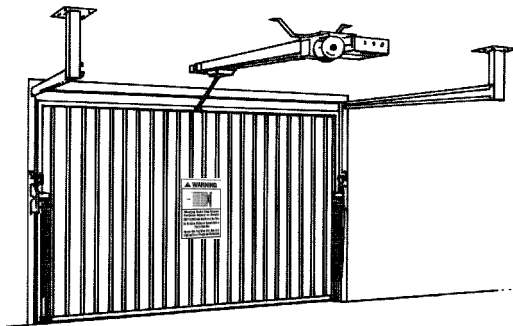

SUGGESTION

We suggest the use and installation of the warning sign provided by Elite Access Systems for safer operation

**WARNING-TO PREVENT
ENTRAPMENT-DO NOT START
DOOR DOWNWARD UNLESS
DOORWAY IS CLEAR**

**AVERTISSEMENT: POUR
EMPÊCHER L'OCCLUSION,
NE PAS FAIRE DESCENDRE
LA PORTE A MOINS QUE
LA PORTE SOIT CLAIRE**

PLACEMENT DE SIGNAL D'AVERTISSEMENT

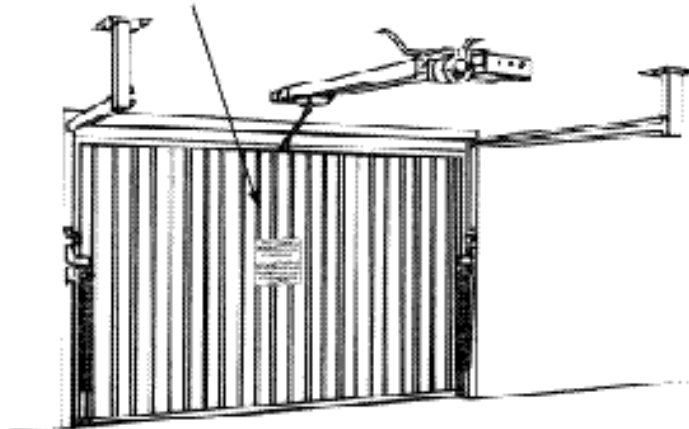

THREE PUSH BUTTON STATION

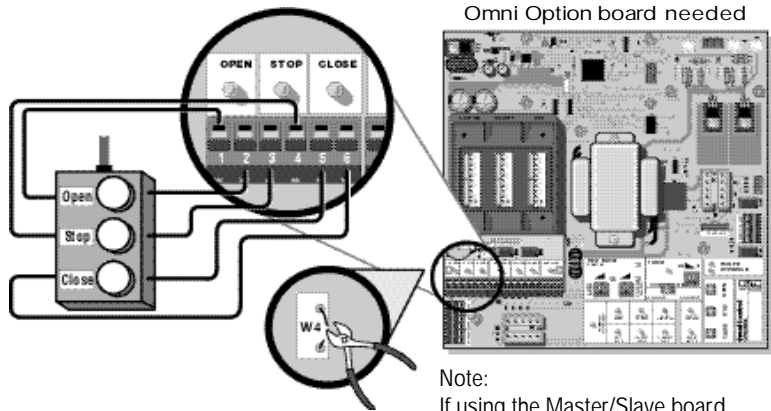

THREE PUSH BUTTON SYSTEM (OPEN-STOP-CLOSE)

- Step 1 - Cut off jumper wire #W4.
- Step 2 - Install optional Omni board.
- Step 3 - Connect **OPEN** push button to #1 & 2.
- Step 4 - Connect **STOP** push button to #3 & 4.
- Step 5 - Connect **CLOSE** push button to #5 & 6.

Note:
If using the Master/Slave board configuration, unplug the Master/Slave link plug on main board and connect it into the optional board M/S link socket.

CAUTION:
Make sure each push button is dry contact and there are no jumper wires between them.

INSTRUCTIONS FOR OPTIONAL SYSTEMS

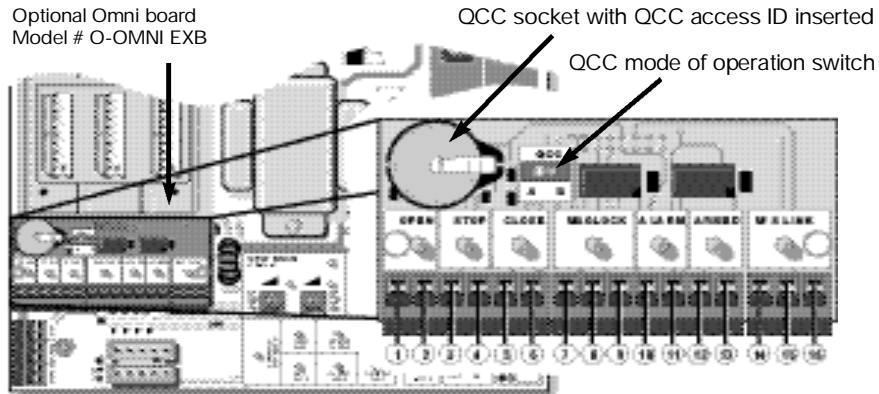

QCC IS DESIGNED FOR SLIDE GATE OPERATORS ONLY!

- | | | |
|---|-----------------------|---------------------------|
| <ul style="list-style-type: none"> 1 & 2 - Open Command 3 & 4 - Stop Command 5 & 6 - Close Command 7 - Common 8 - Normally Closed 9 - Normally Open | }
}
}
}
} | Maglock
or
Solenoid |
| <ul style="list-style-type: none"> 10 & 11 - Burglar Alarm Output 12 & 13 - Burglar Alarm Input 14 - Ground 15 - B 16 - A | }
}
}
} | Master/Slave
RS485 |

SAFETY LOOP SYSTEM

A safety loop prevents the gate from closing on a car or any other vehicle while it is exiting or stopped in the middle of the gate area.

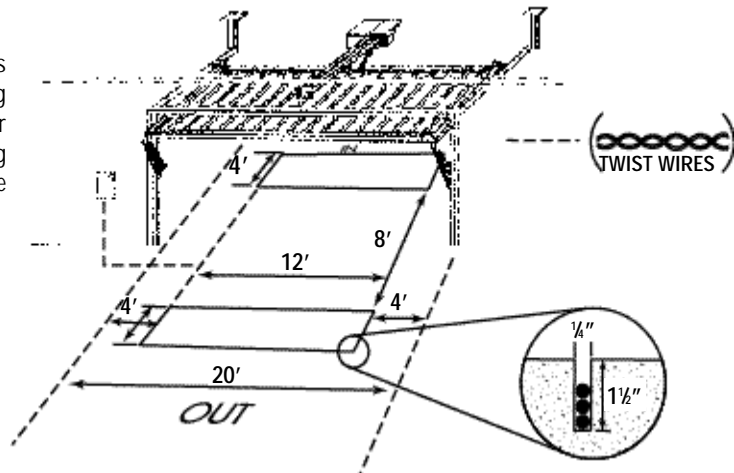

Suggested safety loop installation:

Wire specifications: Follow the manufacturer's instructions. Wire has to be wrapped inside the trench three times. Once you have completed the process, fill-up the wires with proper sealer.

EXIT LOOP SYSTEM

The reason for an exit loop is so the gate will open automatically when a car is exiting.

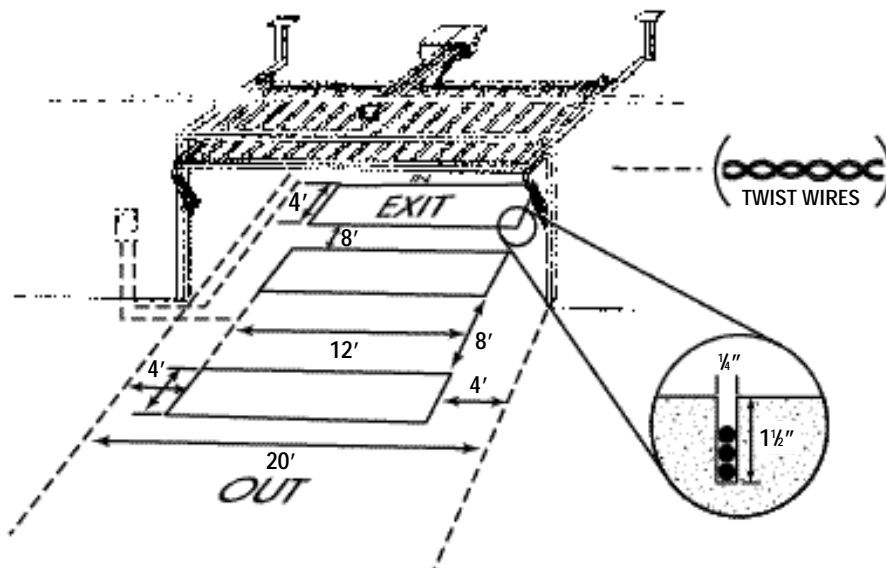

EMERGENCY GATE RELEASE

STEP-1

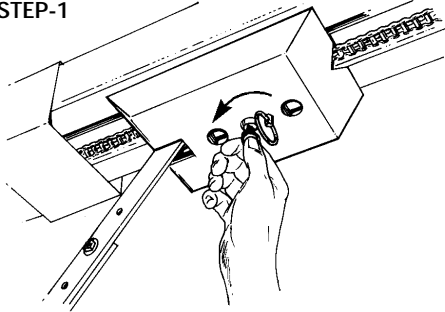

Insert the key and turn to unlock position.

STEP-2

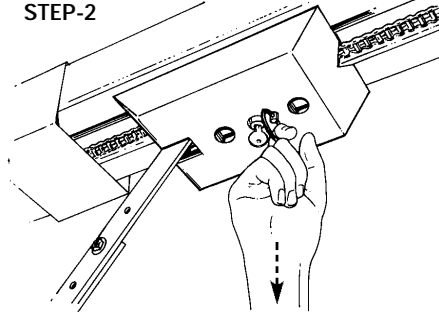

Pull down the release ring.

STEP-3

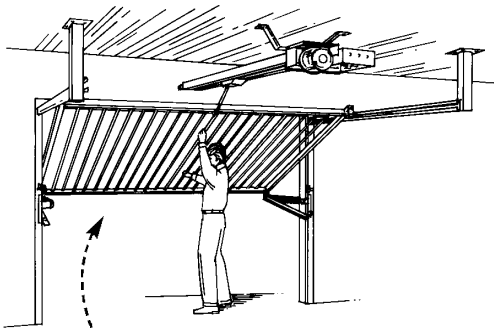

Lift the gate up.

STEP-4

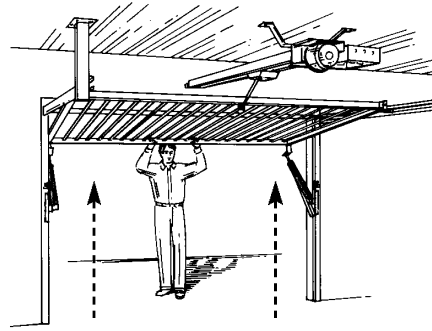

Lift the gate up.

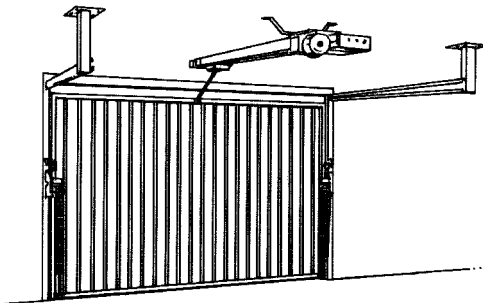

Once the power is back on, the gate will automatically be operational.

CAUTION!



When in open release position, make sure the gate is supported properly to ensure it can not close by itself and cause damage or injury.

HOW TO REPLACE THE CONTROL BOARD

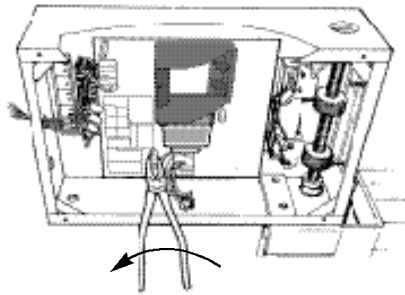

Pull out the two plugs which are connected to the board. Unscrew the three nuts and pull out the control board.

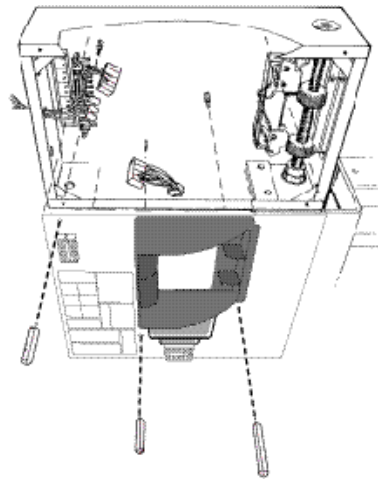

AUDIO ALARM

When one of the following events happen **twice consecutively**, an alarm will sound.

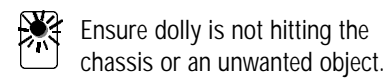
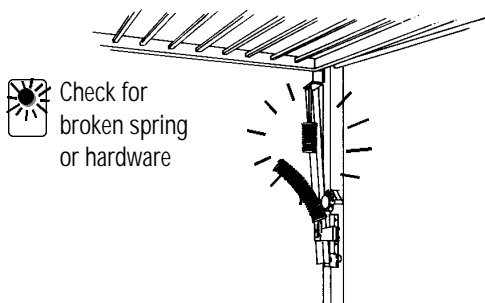

Refer to troubleshooting table.

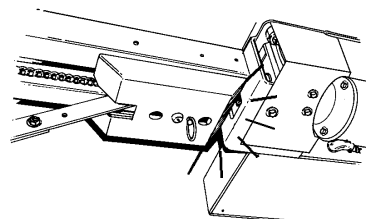
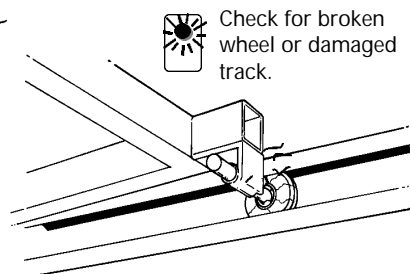

TROUBLESHOOTING LED INFORMATION

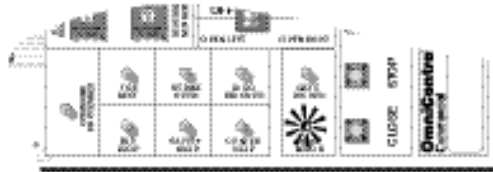
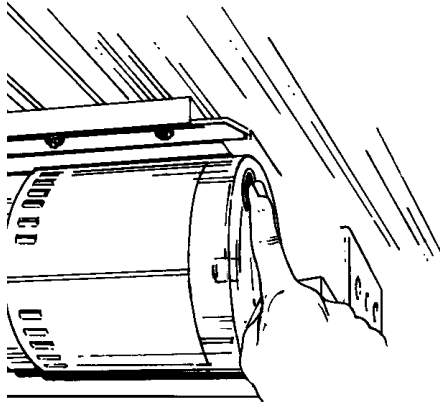

If the gate is not moving in any direction and the reset motor light is on, take a screwdriver and reset thermal breaker on the motor as directed in the picture.

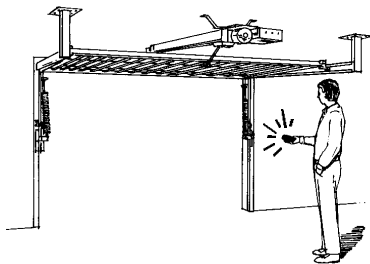
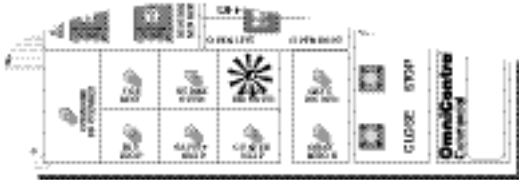

EXAMPLE:
The radio receiver LED is on and the gate remains open. The radio receiver has malfunctioned in the "ON" position.

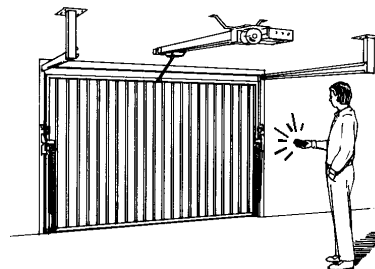

EXAMPLE:
The radio receiver LED is not on and the gate will not open with a transmitter. The radio receiver has malfunctioned in the "OFF" position.

TROUBLESHOOTING TABLE

CONDITION	POSSIBLE CAUSES	SOLUTION
OVERLOAD LED ON And POWER LED OFF	<ol style="list-style-type: none"> Short circuit at terminals 8 and 10 Short circuit at any of the loop detectors in the board Short circuit in the control board 	<ol style="list-style-type: none"> Remove the short circuit condition at the terminals Remove the defective loop detector Sent the board to repair
OVERLOAD LED ON And POWER LED ON	<ol style="list-style-type: none"> Excessive current draw at terminal 10 Over-voltage at the 120 VAC line 	<ol style="list-style-type: none"> Reduce the accessories load from terminal 10 Verify your electrical power
SYSTEM ON LED FLASHING	<ol style="list-style-type: none"> One limit switch is faulty Motor thermal fuse has pop-out 	<ol style="list-style-type: none"> Test the limits and replace the faulty one Reset the motor
REVERSE SENSOR LED ON	<ol style="list-style-type: none"> Gate has encounterer and obstruction during traveling Reverse sensor is extra sensitive 	<ol style="list-style-type: none"> Remove the obstruction Turn counter-clock-wise the reverse sensor pot a bit more and try again
ALARM SENSOR LED ON	<ol style="list-style-type: none"> Gate encountered and obstruction during traveling Alarm sensor is extra sensitive 	<ol style="list-style-type: none"> Remove the obstruction Turn counter-clock-wise the alarm sensor pot a bit more and try again
ALARM SENSOR LED ON	<ol style="list-style-type: none"> Gate encountered and obstruction during traveling Alarm sensor is extra sensitive 	<ol style="list-style-type: none"> Remove the obstruction Turn counter-clock-wise the alarm sensor pot a bit more and try again
COMMAND PROCESSED ON	<ol style="list-style-type: none"> There is a command hold active 	<ol style="list-style-type: none"> This is a normal response of the gate operator. It does not represent necessarily that there is a problem.
TIMER LED BLINKING And COMMAND PROCESSED BLINKING	<ol style="list-style-type: none"> There is a command holding the gate open 	<ol style="list-style-type: none"> This is a normal response of the gate operator. It does not represent necessarily that there is a problem.
TIMER LED BLINKING And COMMAND PROCESSED BLINKING And REVERSE SENSOR LED ON	<ol style="list-style-type: none"> Gate has reopened because it encountered an obstruction while closing. 	<ol style="list-style-type: none"> Any re-new command will resume normal operation. Check for obstructions. You can stop the alarm by using the stop button.
AUDIO ALARM ON	<ol style="list-style-type: none"> Gate has encountered two consecutive obstructions while trying to close or open 	<ol style="list-style-type: none"> Any re-new command will resume normal operation but not a radio command. Check for obstructions.
ANY "LOOP LED" ON And NO VEHICLE ON THE SENSING AREA	<ol style="list-style-type: none"> The loop detector needs to be reset. The wire loop has been disrupted The loop detector needs to work in a different frequency The loop detector is too sensitive 	<ol style="list-style-type: none"> Reset the loop detector (If you use Elite Plug-in Loop detectors, change the setting for sensitivity and come back to your original setting). Verify and correct connections Set a different working frequency Decrease the sensitivity of the loop detector

HOUSE ALARM/PROXIMITY SWITCH CONNECTIONS

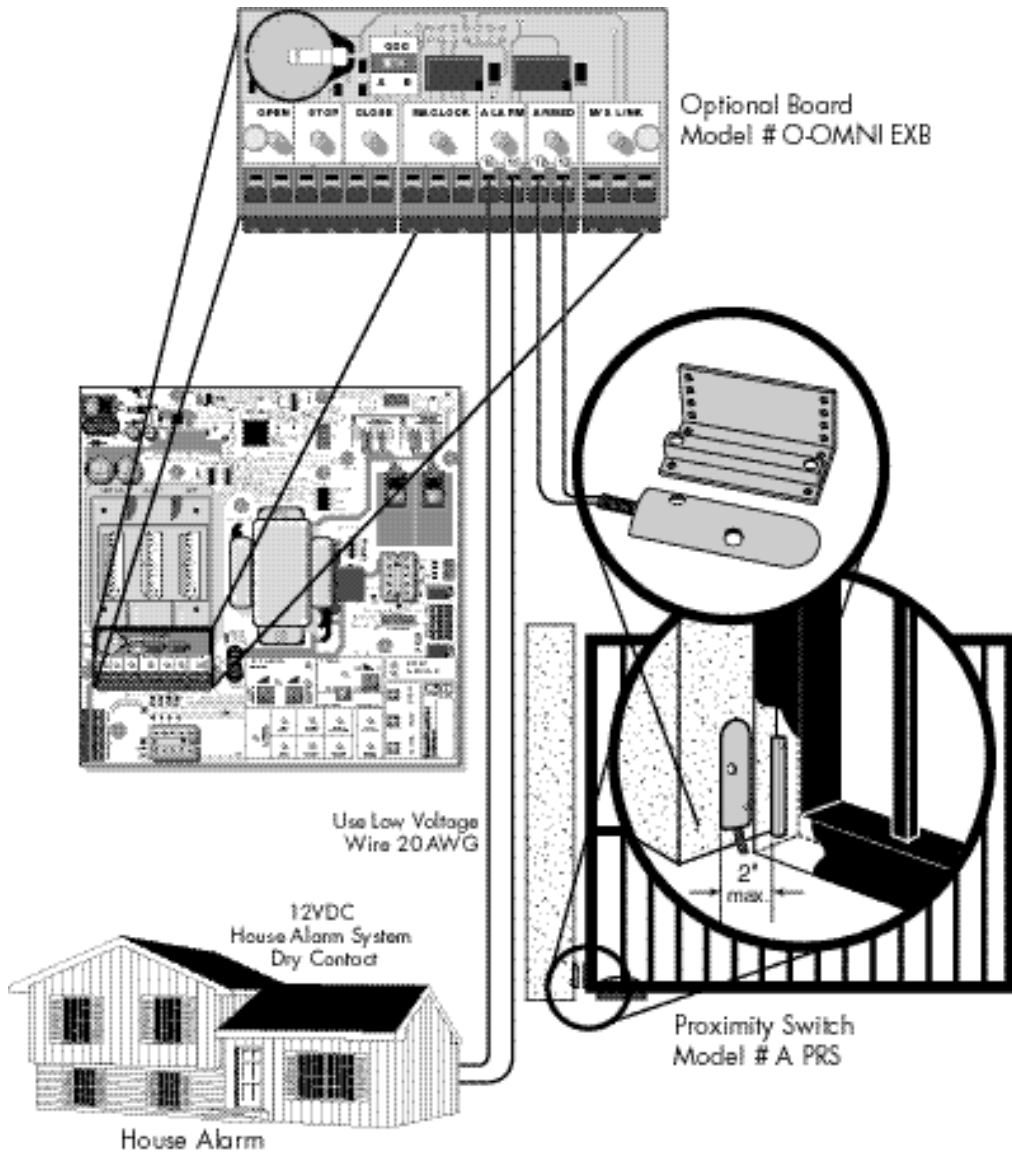

SOLENOID/MAGLOCK J3 CONNECTION

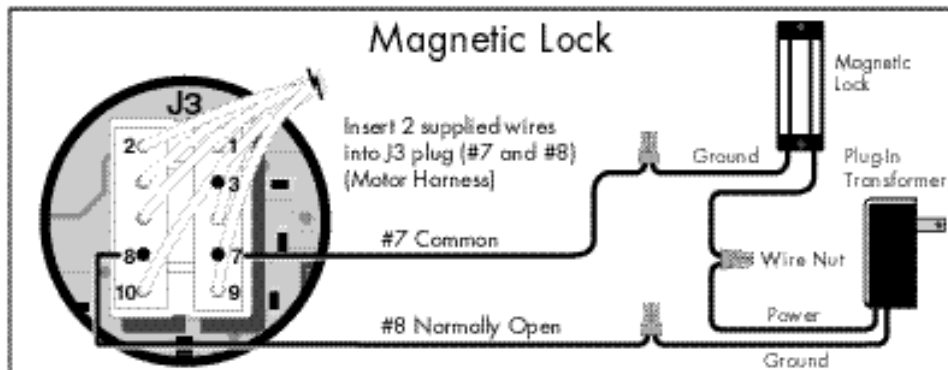
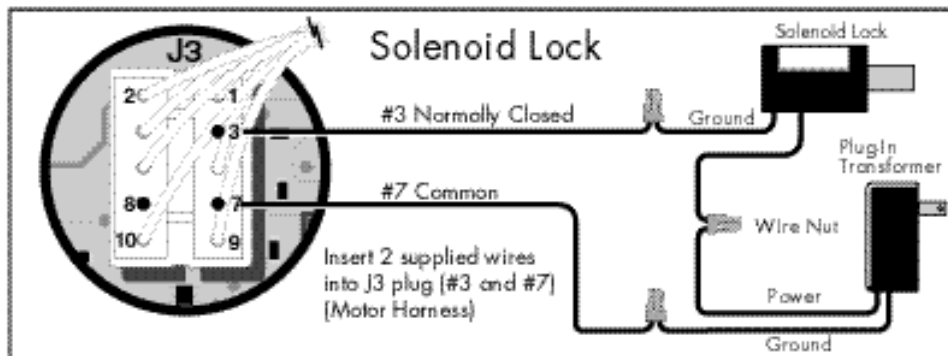
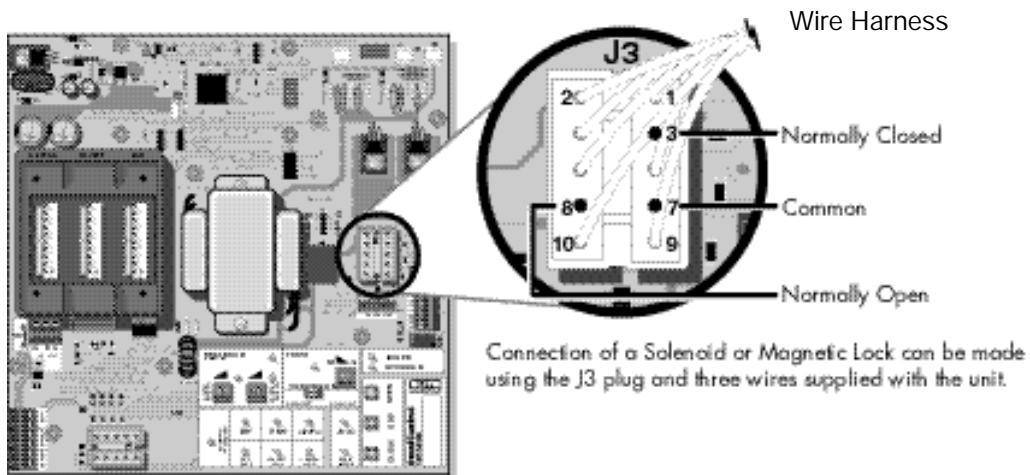

STOP BUTTON ALARM SHUT-OFF

FOR USE WITH OPTIONAL BOARD

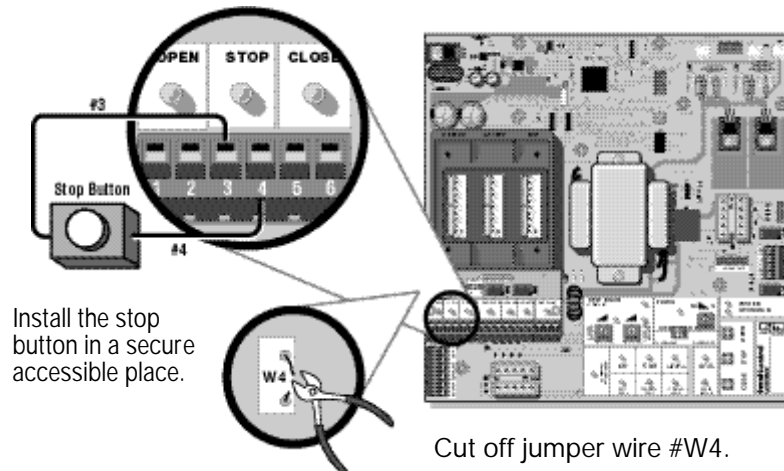

This is an important command required to stop the audio alarm in case it has been triggered.

Otherwise the alarm will sound for 5 minutes and reset itself.

USE THIS BUTTON:

- To stop movement of gate in case of potential entrapment
- To reset the audio alarm (check for obstructions)
- To stop gate operator while traveling

When using the optional board, use the STOP input to connect the stop button.

OPTIONAL BUILT-IN LOOP DETECTORS

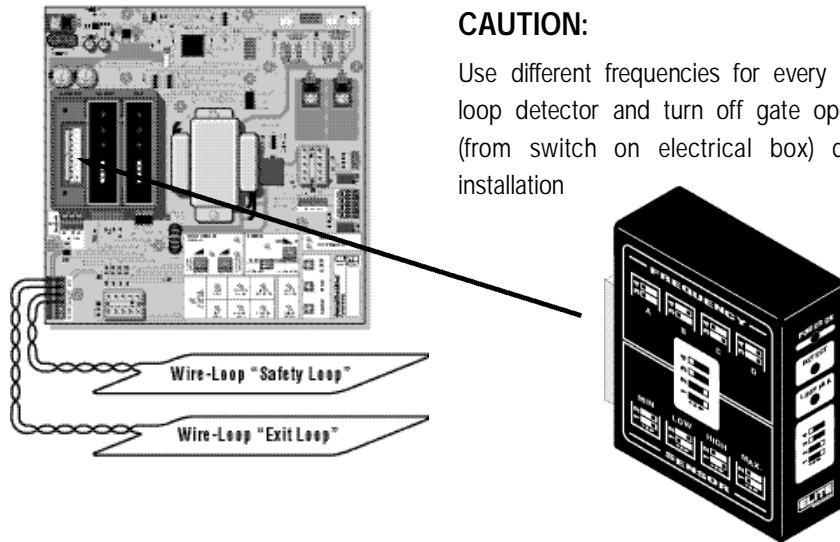

CAUTION:

Use different frequencies for every single loop detector and turn off gate operator (from switch on electrical box) during installation

Elite Loop detectors (Model # ELD) needed to do this function.

SECONDARY ENTRAPMENT WIRING

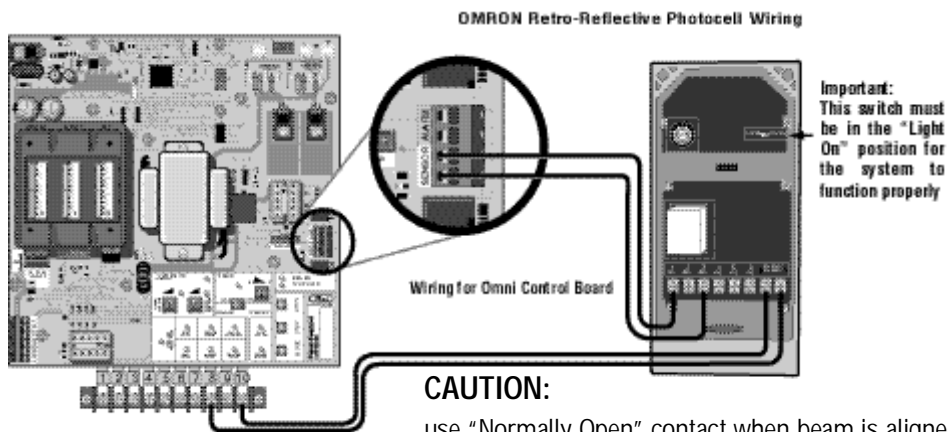

CAUTION:

use "Normally Open" contact when beam is aligned.

If you are going to use a non-contact sensor as a secondary entrapment protection you should use a recognized component to comply with the revised UL 325 intended to be use in class I or class II gate operator. OMRON Retro-Reflective Photocell, Model: E3K-R10K4-NR

ELITE Model # AOMRON

SECONDARY ENTRAPMENT MOUNTING
MOUNTING THE SECONDARY ENTRAPMENT PREVENTION DEVICE

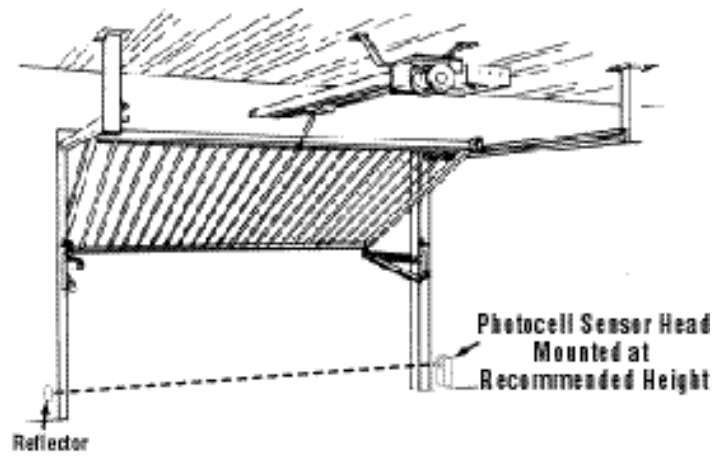

OMRON Retro-Reflective Photocell

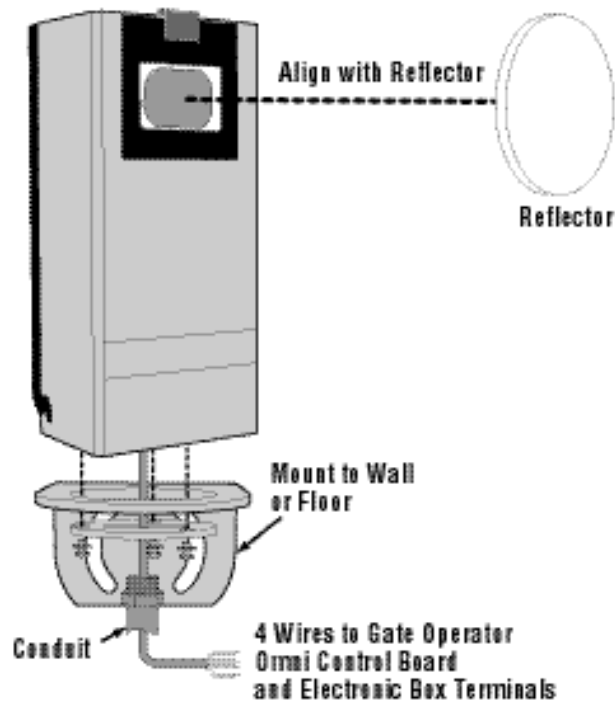

SOLENOID CONNECTION WITH OPTIONAL BOARD

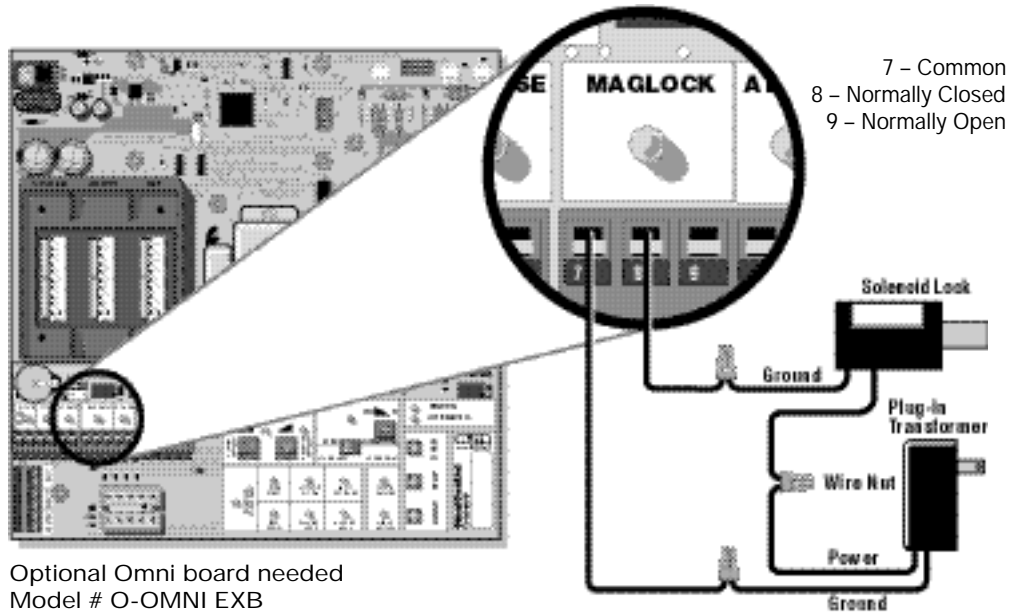

MAGLOCK CONNECTION WITH OPTIONAL BOARD

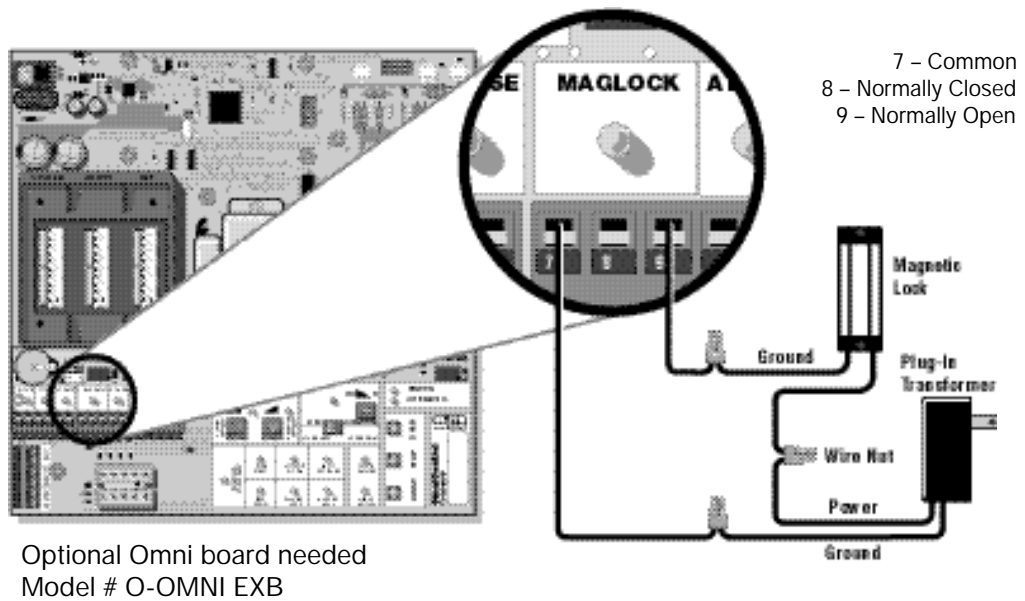

HERCULES PARTS

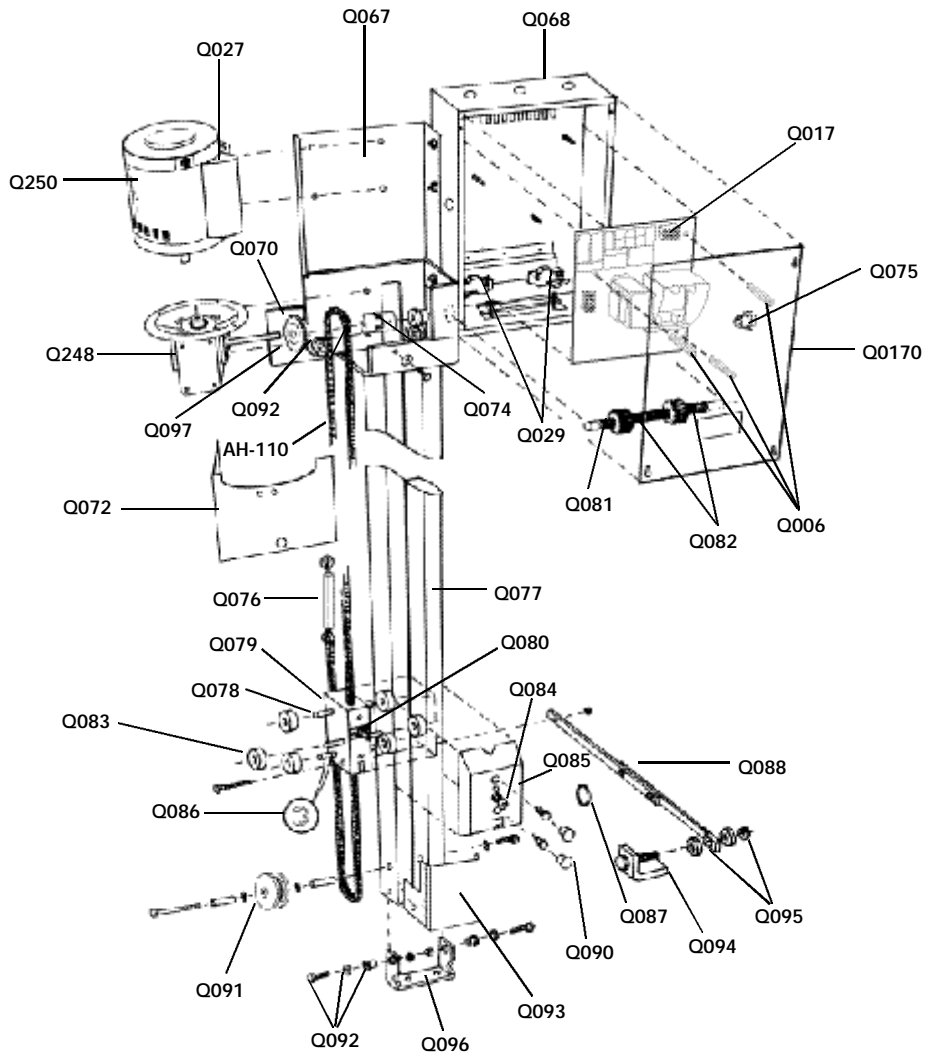

HERCULES PARTS LIST

AH-110 -	CHAIN #41 (per 10' box)	Q083 -	DOLLY WHEELS
Q006 -	PC BOARD NUTS (SET)	Q084 -	EMERGENCY KEY RELEASE
Q017 -	ELECTRONIC CONTROL BOARD	Q085 -	DOLLY COVER
Q027 -	MOTOR CAPACITOR	Q086 -	RETAINING SPRING CLIP
Q029 -	LIMIT SWITCH	Q087 -	EMERGENCY PULLING RING
Q067 -	CHASSIS	Q088 -	GATE ARM
Q068 -	ELECTRONIC BOX	Q090 -	PLASTIC PLUG
Q070 -	DRIVE SPROCKET	Q091 -	IDLER SPROCKET
Q072 -	GEAR BOX COVER	Q092 -	RUBBER ISOLATOR
Q074 -	COUPLING (3/4 x 5/8)	Q092 -	RUBBER ISOLATOR
Q075 -	LIMIT SWITCH BALL BEARING	Q093 -	IDLER SPROCKET COVER
Q076 -	TURN BUCKLE	Q094 -	ARM BRACKET
Q077 -	TRACK (ONE PAIR 10')	Q095 -	ARM BUSHING
Q078 -	TROLLEY WHEEL SHAFT	Q096 -	HEAD BRACKET
Q079 -	TROLLEY BODY	Q097 -	OPERATOR MOUNTING BRACKET
Q080 -	DOLLY LATCH	Q170 -	ELECTRONIC ACCESS PANEL
Q081 -	LIMIT SWITCH BOLT	Q248 -	GEAR REDUCER (40:1)
Q082 -	LIMIT SWITCH NUTS	Q250 -	1/2 HP ELECTRIC MOTOR

MAINTENANCE

1. MAKE SURE THE GATE OPERATES SMOOTHLY WITHOUT THE OPERATOR.
2. MAKE SURE THE GATE TRACK RUNS SMOOTHLY.
3. FOR CHAIN MAINTENANCE YOU CAN ADJUST THE TURN BUCKLE (PART #Q076).
4. IF YOU HEAR AN ALARM SOUND REFER TO AUDIOALARM ILLUSTRATION.
5. WHILE CLOSING IF THE GATE REVERSES OR WHILE OPENING IF THE GATE STOPS, REFER TO STEP 6 (SENSOR NEEDS TO BE ADJUSTED).
6. IF THE GATE IS OUT OF ADJUSTMENT REFER TO STEP 6.
7. REFER TO PARTS LIST.

IF YOU NEED FURTHER ASSISTANCE, PLEASE CALL YOUR LOCAL SERVICE COMPANY.