

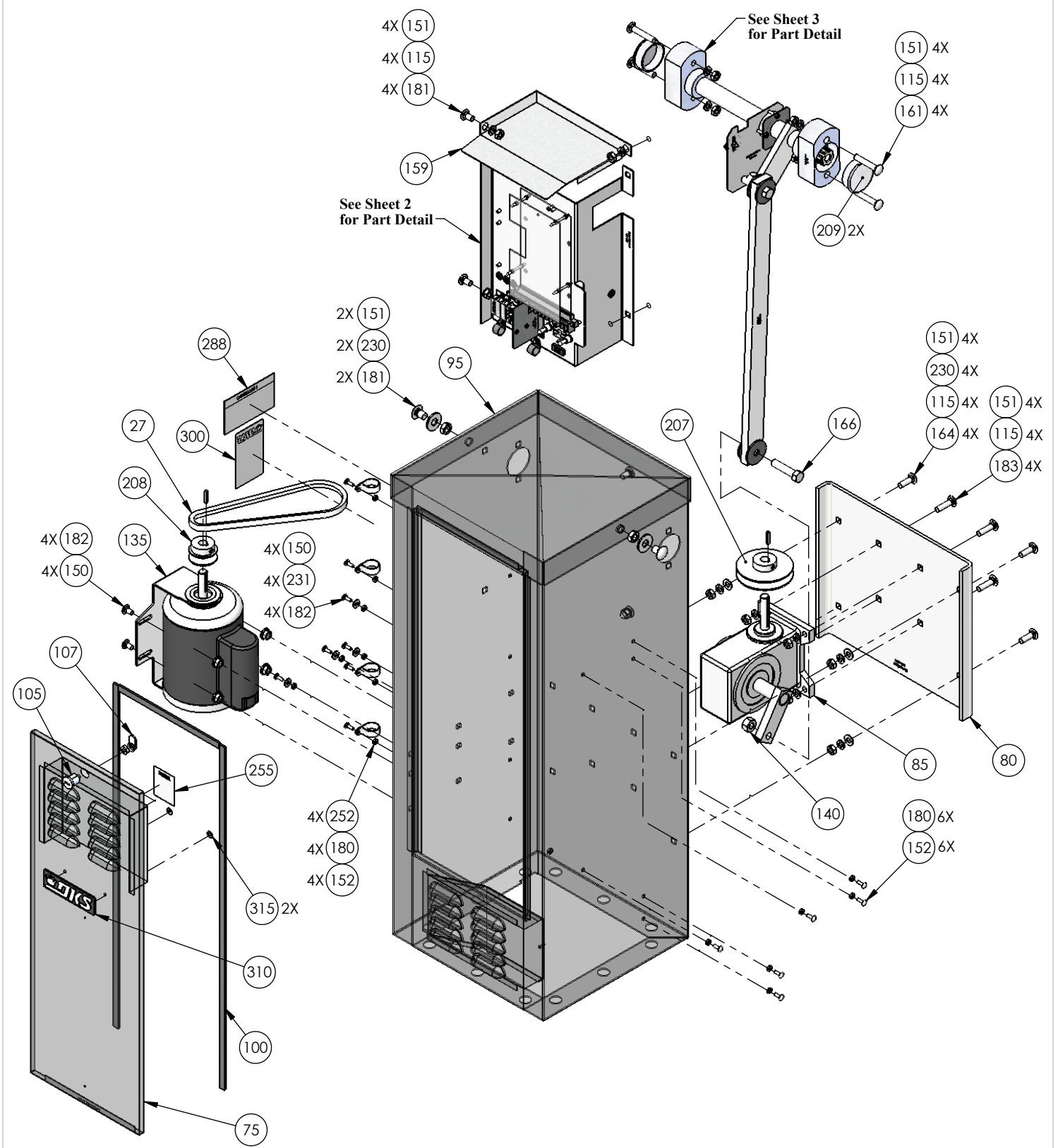

REVISIONS

EO	REV	DESCRIPTION	DATE	APPROVED
--	Y	Revised & Redrawn on SolidWorks	08/03/06	D.C.
04	AA	High Profile Gearbox & Mtg Plate Items 80 & 85 Was: 1601-115 & 1601-023 Low Profile. Added Wiring Diagram Sh 4.	Sal 11/14/06	D.C. 11/14/06



2. Items 250, 251, & 290 Not Shown for Clarity.
 1. See attached reference sheet for BOM; Reference Movex 1601-080 Rev AA.
 Notes: Unless Otherwise Specified.

<p>PROPRIETARY AND CONFIDENTIAL</p> <p>THE INFORMATION CONTAINED IN THIS DRAWING IS THE SOLE PROPERTY OF Door King. ANY REPRODUCTION IN PART OR AS A WHOLE WITHOUT THE WRITTEN PERMISSION OF Door King IS PROHIBITED.</p>	DRAWN	NAME	DATE	 IPB-Model 1601-080, 115V Parking Gate Operator
	CHECKED	Sal	09/21/06	
	COMMENTS:			
	SIZE	DWG. NO.	REV.	
A	1601-880	AA	Scale: None	SHEET 1 OF 6

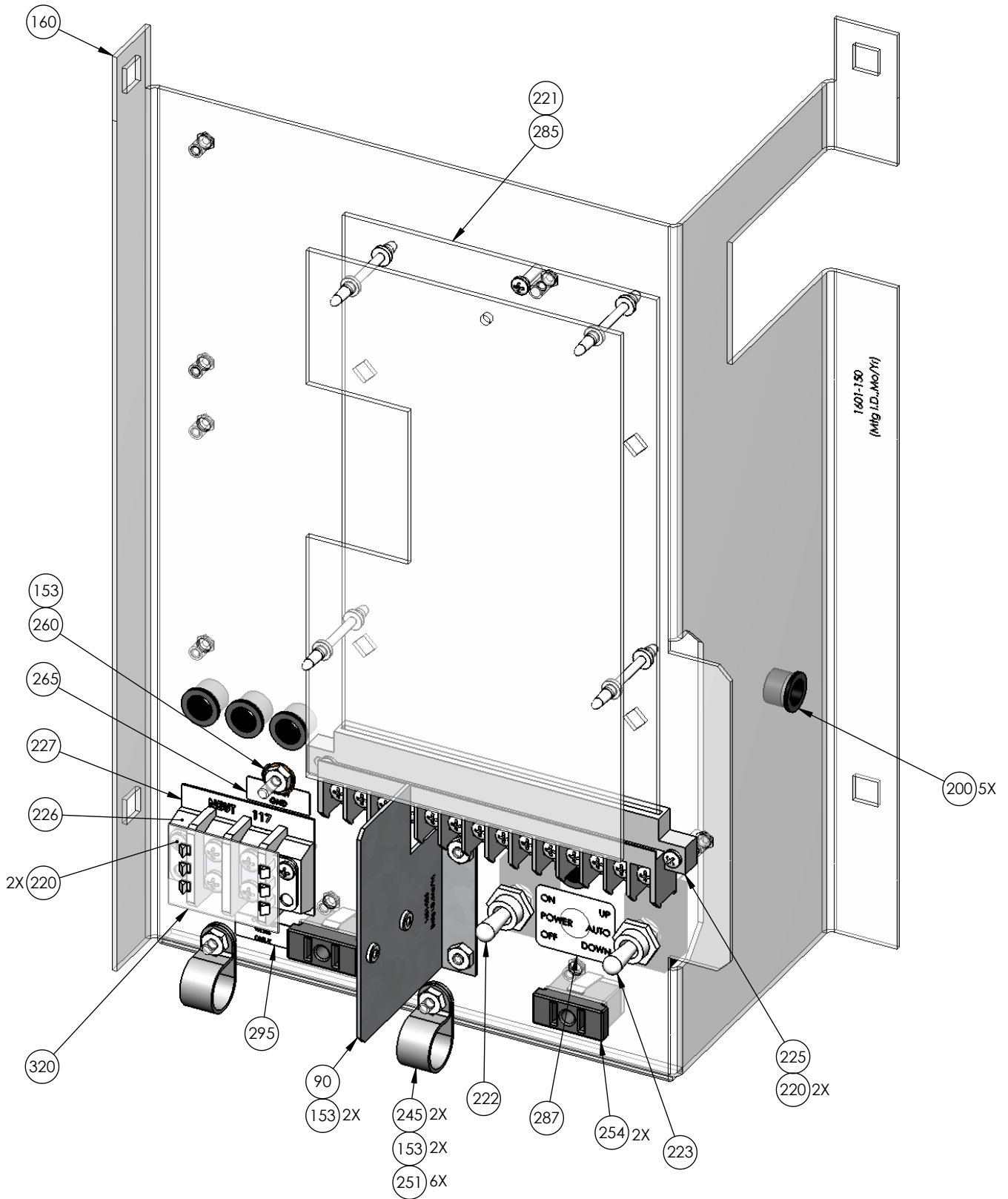

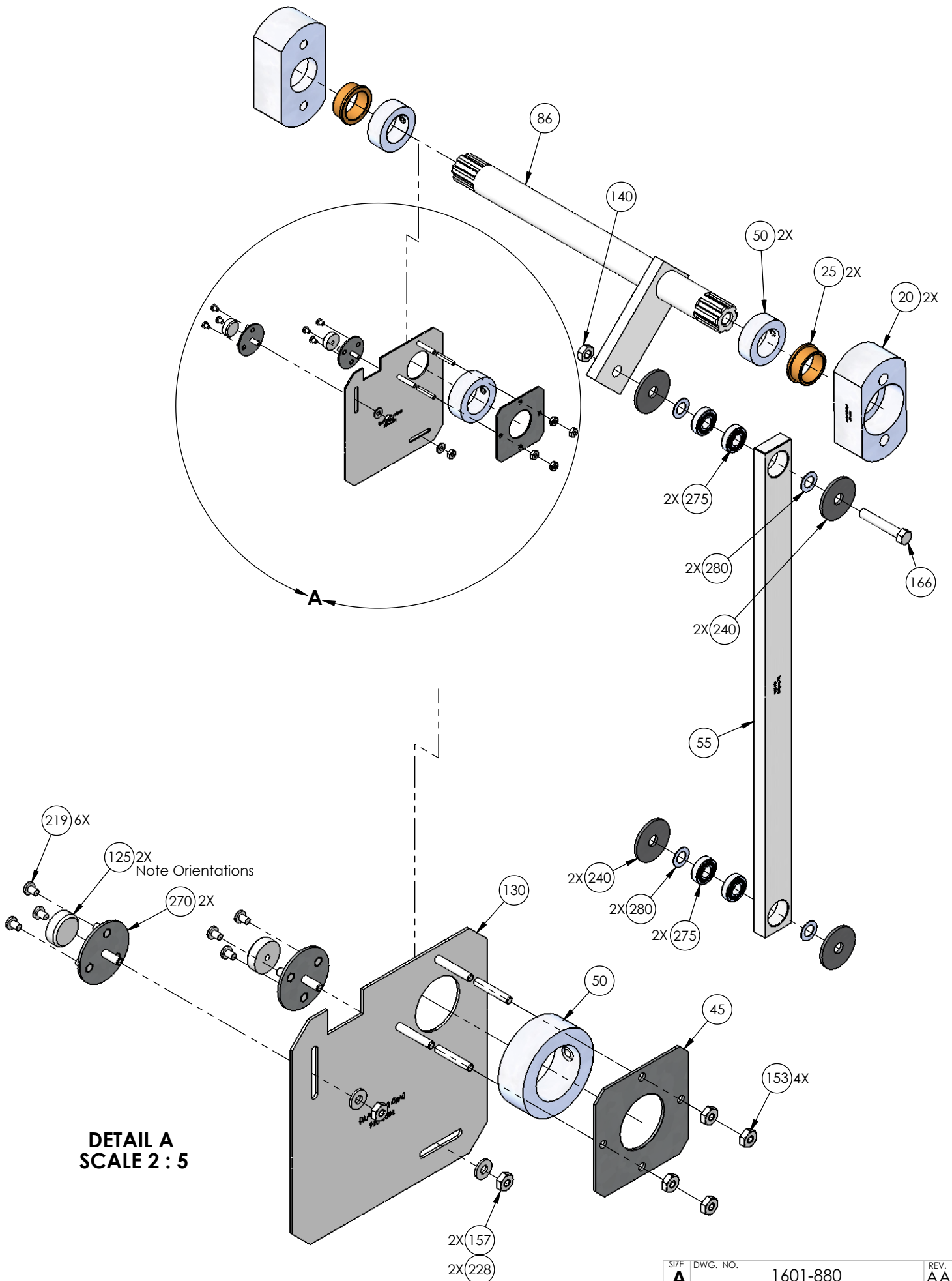

DETAIL A
SCALE 2 : 5

1601 Circuit Board

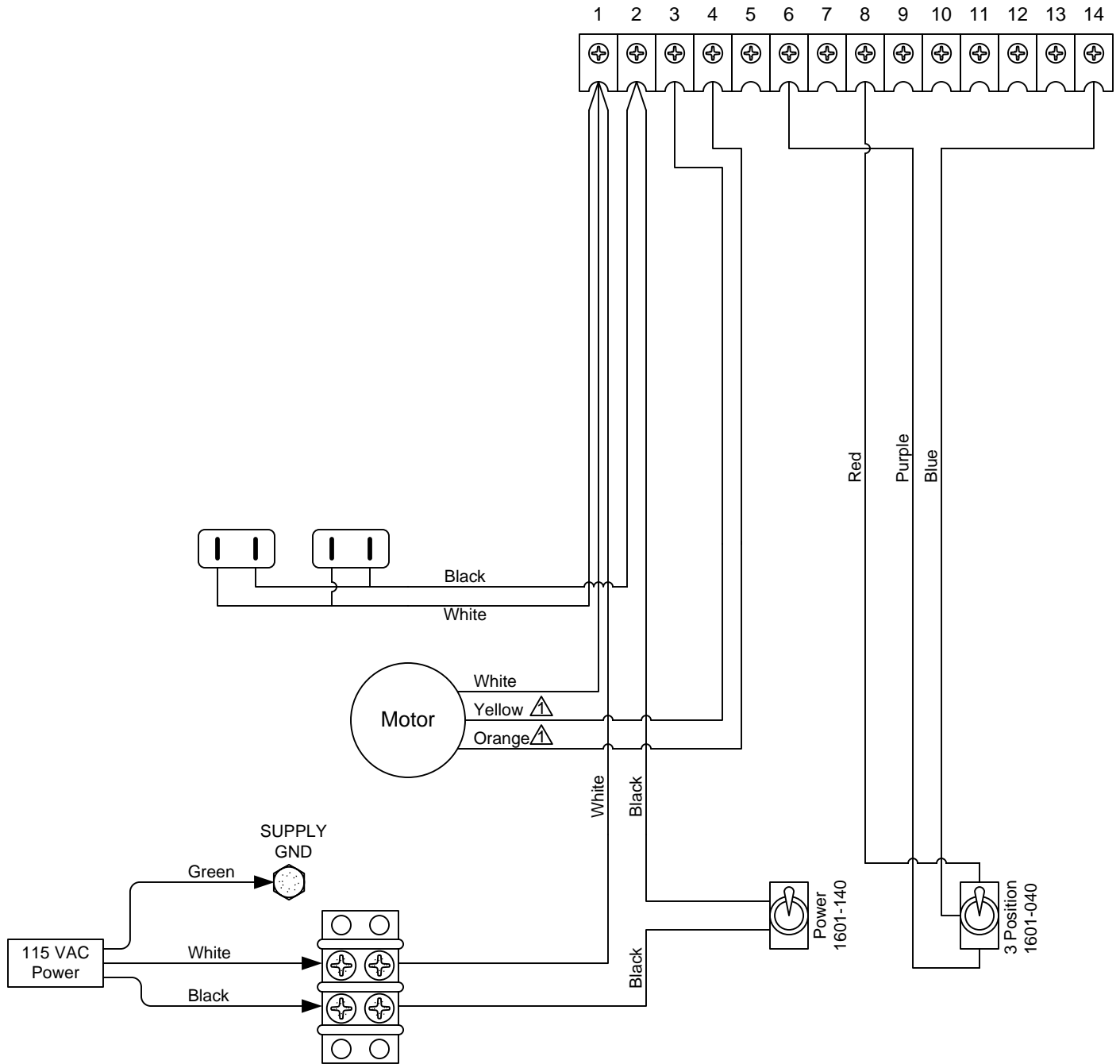

1 Motor wire colors are for 1601 and 1603 operators. In 1602 operators, yellow wire is replaced with a BLUE wire and the orange wire is replaced with a RED wire.

Note: Possibility of electrical shock may occur, above diagram provided for trained technician only.

DWG NO	1601-880	REV	AA
Scale: None		Sheet 4 of 6	



Item	Part Number	Qty	UM	Description	Rev
1	1601-880	1	EA	IPB-Model 1601-080, 115V Parking Gate Operator	AA
20	1601-139	2	EA	Bearing Blk Die Cast 1601	
25	1601-032	2	EA	Bearing 1 1/2OD x11/4ID x 5/8L	
27	1601-026	1	EA	Belt 26"	
45	1601-017	1	EA	Collar "Sandwich" Plate	
50	2600-061	3	EA	Collar 2"OD x 1 1/4"ID x 5/8"L	
55	1601-029	1	EA	Connecting Link	
75	1601-075	1	EA	Door	
80	1601-215	1	EA	Mount Plate Gearbox	A
85	1601-027	1	EA	Gearbox 1601	A
86	1601-222	1	EA	Shaft Assembly 1601 Splined	
90	1601-055	1	EA	Divider - High/Low Voltage	
95	1601-100	1	EA	Housing	
100	4001-018	6	FT	Weather Stripping (50' rolls)	
105	4001-035	1	EA	Lock N16058BDxSFx2K Key 16120	
107	1702-503	1	EA	Cam 1.1/4	
115	2620-047	16	EA	Lockwasher 3/8"	
125	2600-817	2	EA	Magnet	
130	1601-016	1	EA	Mount Plate Magnet	
135	1601-074	1	EA	Motor 1/2 H.P. Emerson	
140	2620-440	2	EA	Nut Hex 1/2-13 GR8	
150	2620-411	8	EA	Nut Hex Flange Lock 5/16-18	
151	2620-405	18	EA	Nut Hex 3/8-16	
152	2902-006	10	EA	Nut Nylon 10-32	
153	2902-004	9	EA	Nut Nylon Lock 8-32	
157	2620-401	2	EA	Nut Hex 8-32	
159	1601-152	1	EA	Mount Plate - PC Board Top	
160	1601-150	1	EA	Mount Plate - PC Board Bottom	
161	2615-673	4	EA	Bolt Carr SS 3/8-16 x 2 1/4 Painted	
164	2615-669	4	EA	Bolt Carriage SS 3/8-16 x 11/4 Painted	
166	2615-184	2	EA	Bolt Hex Head 1/2-13 x 2 1/4 GR8	
180	2615-645	10	EA	Bolt Carr SS 10-32 x 5/8 Painted	
181	2615-667	6	EA	Bolt Carr SS 3/8-16 x 3/4 Painted	
182	2615-662	8	EA	Bolt Carr SS 5/16-18 x 5/8 Painted	
183	2615-674	4	EA	Bolt Carriage 3/8-16 x 1 3/4 Painted	
200	2600-820	5	EA	Bushing 1/2	
207	1601-018	1	EA	Pulley 4" OD 5/8" Bore	
208	1601-033	1	EA	Pulley 2"ODx5/8	
209	2600-882	2	EA	Hole Plug Plastic 2.25" Hole	
219	2616-006	6	EA	Screw Phillip Head 6-32 x 3/16	
220	2616-003	4	EA	Screw Phillips Head 6-32 x 3/4	
221	2616-002	1	EA	Screw Phillips Head 6-32 x 1/2	
222	1601-040	1	EA	Switch Toggle ON-OFF-ON MOMEN	
223	1601-041	1	EA	Switch Toggle SPST 2POS	
225	1601-007	1	EA	Terminal 14 Pin	
226	2600-414	1	EA	Terminal Block-2 Position	
227	2600-410	1	EA	Marker Strip Silkscn Both Side	
228	2802-003	2	EA	Washer #8 SAE	
230	2620-029	6	EA	3/8 USS Flat Washer	

231	2620-019	4	EA	3/8 SAE Flat Washer
240	2620-131	4	EA	Washer 1 7/8"OD x 1/2"ID 1/8 Thk
245	2600-619	2	EA	Wire Clp-5/8" Concord 770-1209
250	1601-008	1	EA	Wire Set 1601/1602
251	1804-031	6	EA	Tie Wrap 4"
252	2600-639	4	EA	Wire Clamp-1"
253	2600-749	2	EA	Wire Connector STA-KON RC6
254	1200-028	2	EA	Outlet Snap-In Leviton 1306
255	2599-008	1	EA	Label Patent
260	2600-439	1	EA	Washer Cup - Brass
265	2599-006	1	EA	Decal SUPPLY GND
270	1601-044	2	EA	Holder - Magnet
275	1601-060	4	EA	Bearing-Sealed 1/2ID x 1 1/8OD
280	1601-185	4	EA	Washer Race .515"IDx.875"OD CH
285	1601-010	1	EA	PCB Parking Gate
287	2599-012	1	EA	Decal 1601 Switch
288	2599-035	1	EA	Decal-Warning, Parking Gate
290	2560-010	1	EA	Information Packet 1601
295	2599-014	1	EA	Decal Copper Wire Only
300	2599-199	1	EA	Label Universal
310	2600-732	1	EA	Nameplate Plastic DKS
315	2802-040	2	EA	Washer Push on Clamp
320	3129-002	1	EA	Terminal Block Cover 2 Position